



Turn to the experts

Product Data

Aquazone™

Compact Water Source Heat Pumps

1/2 to 6 Nominal Tons



AQUAZONE™



50PCH, PCV 007-070
Compact Water Source Heat Pumps
with Puron® Refrigerant (R-410A)

Carrier's Aquazone WSHPs are an efficient, compact solution for new construction and retrofit applications

Single-package horizontally and vertically mounted water source heat pumps (WSHPs) with compact cabinet and standard features:

- Compact design allows for replacement of legacy WSHPs from Carrier and other manufacturers.
- Cabinet constructed of heavy gauge galvanized steel to ensure long service life.
- Interior panels feature an acoustical fiberglass lining for quiet operation.
- Large access panels for ease of maintenance and service.
- Suitable for boiler/tower loop applications with standard operating range of 50°F to 100°F entering water temperature.
- Rotary (size 007-018) or scroll (size 024-070) compressors.
- Double isolated compressor mounting for quiet operation
- Non-ozone depleting Puron refrigerant (R-410A)
- Direct drive fan assembly with Permanent Split Capacity (PSC) motor for reliable operation.
- Factory installed unit protection module (UPM) ensures reliable operation and simplifies troubleshooting.
- Manufactured in an ISO 9001 certified facility.

Operating efficiency

Aquazone WSHP units offer cooling EERs (energy efficiency ratios) to 17.65 and heating COPs (coefficients of performance) to 5.1.

All efficiencies stated are in accordance with the latest edition of ISO/AHRI/ASHRAE/ISO 13256-1 and provide

among the highest ratings in the industry.

High quality construction and testing

All units are manufactured to meet extensive quality control standards. An automated control system provides continuous monitoring of each unit and performs quality control checks as equipment progresses through the production process. An automated end of line run test verifies component functionality. Units are produced in an ISO 9001 production facility.

Cabinet

Heavy gage galvanized sheet metal cabinet construction designed with large access panels for easy maintenance and service. Cabinet interior surfaces are lined with 1/2 in. thick, 1-1/2 lb fiberglass insulation. Sheet metal surfaces are treated for maximum corrosion protection to provide resilience for long term vitality. Compact cabinet dimensions fit tight space limitations in both horizontal and vertical configurations.

Compressor

Compact Aquazone units include a rotary compressor in sizes 007-018 and a scroll compressor in size 024-070 units. Compressors are mounted on a double isolated system (i.e., from the cabinet) that maximizes vibration isolation and minimizes transmission to the unit structure.

Puron® refrigerant (R-410A)

Puron refrigerant (R-410A) is a non-chlorine based environmentally balanced, non-ozone depleting refrigerant. Puron refrigerant characteristics, compared to R-22, have:

- Binary and near azeotropic mixture of 50% R-32 and 50% R-125.
- Higher efficiencies (50 to 60% higher operating pressures).

- Virtually no glide. Unlike other alternative refrigerants, the two components in Puron refrigerant have virtually the same leak rates.

Therefore, refrigerant can be added if necessary.

Permanent split capacitor motors (PSC)

The standard motor for all 50PC model heat pumps is a PSC motor. For all models other than 575-volt units, the supplied motor has 3-speed taps for field adjustability. The 575-v motor has a single speed tap.

Hanging brackets

All horizontal units come standard with hanging bracket kits for suspending the unit from field-supplied hanger rods. These kits include heavy duty steel brackets and rubber grommets for sound and vibration isolation from the building structure.

Water connections

All water connections are heavy duty bronze FPT fittings securely fastened to the unit corner post. This allows connecting to a flexible hose kit without the use of a backup wrench making for easier, faster installation.

Refrigeration/water circuit

All units have a sealed refrigerant circuit including a high-efficiency rotary or scroll compressor. Simplified refrigerant circuits provide easy maintenance, higher accuracy and excellent performance. Also, standard are a reversing valve (4-way valve), water-to-refrigerant coaxial (tube-in-tube) coil, and enhanced aluminum fin/ripled copper tube air-to-refrigerant heat exchanger coil.

AHRI/ISO

Aquazone units have AHRI (Air-Conditioning, Heating, and Refrigeration Institute)/ISO, NRTL (Nationally Recognized Testing Lab), or CSA (Canadian Standards Association) labels and are factory tested under normal operating conditions at nominal water flow rates. Quality assurance is provided via testing report cards shipped with each unit to indicate specific unit performance under cooling and heating modes.

Quiet operation

All 50PC units have a unique floating basepan; the compressor is mounted on a heavy steel plate which rests on a high density rubber pad on the base of the unit. In addition, compressors are mounted on rubber grommets. This double isolation is standard in all 50PC

Table of contents

	Page
Features/Benefits	2
Model Number Nomenclature	5
AHRI/ISO Capacity Ratings	6
Physical Data	7
Options and Accessories	8
Dimensions	13
Performance Data	21
Electrical Data	25
Application Data	28
Control Sequence of Operation	32
Guide Specifications	38

units preventing vibration and noise transmission from the compressor to the unit structure, resulting in exceptionally quiet operation.

Cabinets are fully insulated to reduce noise transmission, low speed blowers are used for quiet operation through reduced outlet air velocities, and air-to-refrigerant coils are designed for lower airflow coil face velocities. A mute package is also available for extremely noise sensitive applications.

Indoor air coil

All units come standard with a copper tube, aluminum-fin air coil. These air coils employ lanced fin and rifled tubing for maximum heat transfer. Large face areas result in lower face velocity reducing sound while ensuring high latent heat removal for maximum dehumidification in the cooling mode.

Thermostatic expansion valve

All 50PC units are equipped with a thermostatic expansion valve (TXV) metering device to ensure reliable operation across a wide range of entering air and water temperatures.

Design flexibility

Airflow configurations for horizontal units are available in patterns including left or right return or straight through or end discharge. Horizontal units are field convertible between straight through (left or right) discharge and end discharge. Vertical units are available in left or right return with top discharge. Other combinations may be available as a special order. Standard water temperature range between 50 and 100°F offers maximum design flexibility for boiler/tower applications. Water flow rates as low as 2.5 gpm per ton assist with selection from a various range of circulating pumps. Factory-installed options are offered to meet specific design requirements.

Safe, reliable operation

Standard safety features for the refrigerant circuit include a high-pressure switch, low-pressure sensor to detect refrigerant loss. Equipment safety features include water loop temperature monitoring, voltage protection, water coil freeze protection, and standard electronic condensate overflow shutdown. All safety features are tested and run at the factory to assure proper operation of all components and safety switches.

All components are carefully designed and selected for endurance, durability, and carefree day-to-day operation.

The Aquazone™ unit is shipped to provide internal and external equipment protection. Shipping supports are placed under the blower housing. In addition, horizontal and vertical units are both mounted on oversized pallets with lag bolts for sturdiness and maximum protection during transit.

Ease of installation

The Aquazone unit is packaged for simple low cost handling and requires minimal installation. All units are pre-wired and factory charged with refrigerant. Horizontal units include factory-installed hanger isolation brackets. Water connections (FPT) and condensate drains (FPT) are anchored securely to the unit cabinet.

Simple maintenance and serviceability

The Aquazone WSHP units are constructed to provide easy maintenance. All units allow easy access to the compressor section from 2 sides with large removable panels. Additional panels allow access to the blower and control box sections.

The blower housing assembly can be serviced without disconnecting ductwork from the dedicated blower access panel. Blower units come with permanently lubricated bearings for worry-free performance. Blower inlet rings allow blower wheel removal without having to remove the housing or ductwork connections.

Electrical disconnection of the blower motor and control box is easily accomplished via quick disconnects on each component.

Easy removal of the control box from the unit provides access to all refrigeration components.

The refrigeration circuit is easily tested and serviced through high and low pressure ports integral to the refrigeration circuit.

Maximum control flexibility

All Aquazone water source heat pumps feature a factory installed and configured unit protection module (UPM), which regulates unit operation, features integrated safeties, and simplifies unit troubleshooting.

The UPM provides control of the unit compressor, reversing valve, fan, safety features, waterside economizer and hot gas reheat control. It also provides troubleshooting fault indication

features. Additional features and functions of the UPM include:

Anti-short cycle timer

Provides a minimum off time to prevent the unit from short cycling. The 5-minute timer energizes when the compressor is deenergized, resulting in a 5-minute delay before the unit can be restarted.

Random start relay

Provides a random delay in energizing each different WSHP unit. This option minimizes peak electrical demand during start-up from different operating modes or after building power outages. Each controller has a unique random start delay ranging from 270 to 300 seconds after power is applied to the board.

High and low pressure refrigerant protection

Safeguards against unreliable unit operation and prevents refrigerant from leaking.

Condensate overflow sensor

Sensor is an electronic sensor mounted to the drain pan. When condensate pan liquid reaches an unacceptable level, the unit is automatically deactivated and placed in a lockout condition. The sensor recognizes 30 continuous seconds of overflow as a fault condition.

High and low voltage protection

Provides safety protection from excessive or low voltage conditions.

Automatic intelligent reset

Will automatically restart unit 5 minutes after shutdown if the fault has cleared. Should a fault occur 2-4 times sequentially (field selectable), lockout will occur.

Water coil freeze protection (selectable for water or anti-freeze)

Provides a field selectable switch for water and water/glycol solution systems which initiates a fault when temperatures exceed the selected limit for 30 continuous seconds.

Alarm relay setting

Is a selectable 24-v or pilot duty dry contact for activating a remote alarm.

Low pressure bypass timer

The low pressure switch is bypassed for 120 seconds after a call for compressor operation to prevent nuisance low pressure lockouts during cold start-up in the heating mode.

Service Test mode with diagnostic LED (light-emitting diode)

Allows service personnel to check the operation of the WSHP and control system efficiently. Upon entering Test mode, time delays speed up, and the Status LED flashes a code to indicate the last fault experienced. This mode provides easy fault diagnosis; based on the fault code that the status LED flashes. Carrier troubleshooting tables provide easy reference to typical problems.

LED visual output

Indicates high pressure, low pressure, low voltage, high voltage, air/water freeze protection, condensate overflow, and control status via a LED panel.

Lockout reset

Can be accomplished by turning the unit thermostat off and then back on or

by shutting off unit power at the circuit breaker. The method of reset is selectable by the DIP switch on the unit control board.

Complete C Control Package

The Complete C control package is the standard control package for all 50PC units and includes the following:

- Unit Protection Module (UPM)
- 50-VA transformer (tapped to 230V for all 208V/230V units)
- Factory labeled terminal strip thermostat input for field provided thermostat or DDC control
- Factory provided wiring diagram affixed to the control enclosure access panel

Better B Control Package

The Better B control package includes all of the features of the standard Complete C control package, minus the capability for Waterside Economizer control and dehumidification control via Hot Gas Reheat. The Better B control package is not available with the HGRH or Waterside Economizer options. The Better B option includes the following:

- Unit Protection Module (UPM)
- 75-VA transformer
- Factory labeled terminal strip thermostat input for field provided thermostat or DDC control
- Factory provided wiring diagram affixed to the control enclosure access panel

Model number nomenclature



50PCH 024 B C C 3 E C C 1

Aquazone™ Compact Water Source Heat Pump with Puron® Refrigerant (R-410A)

50PCH – Horizontal Configuration
50PCV – Vertical Upflow Configuration

Nominal Capacity - Tons

007 – 1/2* 024 – 2 042 – 3-1/2
009 – 3/4* 030 – 2-1/2 048 – 4
012 – 1* 036 – 3 060 – 5
015 – 1-1/4 041 – 3-1/2* 070 – 6
018 – 1-1/2

Horizontal Airflow Configuration

Return	Discharge	Blower Motor
B – Right	Back	PSC
C – Right	Left	Constant Airflow ECM
D – Right	Back	Constant Airflow ECM
E – Left	Right	PSC
F – Left	Right	Constant Airflow ECM
G – Left	Back	Constant Airflow ECM
N – Right	Left	Constant Torque ECM
P – Right	Back	Constant Torque ECM
S – Left	Back	PSC
W – Left	Right	Constant Torque ECM
Y – Left	Back	Constant Torque ECM
Z – Right	Left	PSC

Vertical Airflow Configuration

J – Left	Top/Bottom	Constant Torque ECM
K – Right	Top/Bottom	Constant Torque ECM
L – Left	Top/Bottom	PSC
R – Right	Top/Bottom	PSC
T – Left	Top	Constant Airflow ECM
V – Right	Top	Constant Airflow ECM

Control

B – Better B Control Package
C – Standard C Control Package
D – Deluxe D Control Package
W – WSHP Open DDC Control

Factory-Installed Options

1 – None
2 – Waterside Economizer
8 – MERV 8 Filter
9 – MERV 13 Filter

Operating Range/Sound Option/Insulation

A – Extended Range (25 to 110°F)
C – Standard Range (50 to 100°F)
D – Extended Range, 1/2-in. Closed Cell Foam
E – Standard Range, 1/2-in. Closed Cell Foam
F – Extended Range, Mute, Closed Cell Foam
J – Extended Range, Mute
N – Standard Range, Mute
P – Standard Range, Mute, Closed Cell Foam

Valve Options

A – 2-Way Solenoid
B – Measureflow (3 gpm autoflow reg)
C – None
D – 2-Way Solenoid with Measureflow

Revision Code

E – Revision E
H – Revision H (50PCV012 Only)

Voltage

0 – 115-1-60
1 – 575-3-60
3 – 208/230-1-60
4 – 265-1-60
5 – 208/230-3-60
6 – 460-3-60
A – 575-3-60 with Disconnect
B – 115-1-60 with Disconnect
C – 208/230-1-60 with Disconnect
D – 265-1-60 with Disconnect
E – 208/230-3-60 with Disconnect
F – 460-3-60 with Disconnect

Refrigerant Circuit Options

Option	Non-Coated Air Coil		Coated Air Coil	
	Copper	Cupronickel	Copper	Cupronickel
Standard	C	N	A	J
Hot Gas Reheat	E	P	D	F
Hot Gas Bypass	T	S	U	W
Hot Gas Bypass & Reheat	L	M	R	V

LEGEND

ECM — Electronically Commutated Motor
PSC — Permanent Split Capacitor

NOTE: Configuration and option availability are subject to change. Please refer to WSHP Builder for availability.

50PC Units with Extended Range and Copper Coils^{a,b,c,d,e}

MOTOR OPTION	50PC UNIT SIZE	WATER LOOP HEAT PUMP				GROUND WATER HEAT PUMP				GROUND LOOP HEAT PUMP				CFM	GPM
		Cooling 86°F		Heating 68°F		Cooling 59°F		Heating 50°F		Cooling 77°F		Heating 32°F			
		Capacity BTU/h	EER BTU/W-h	Capacity BTU/h	COP	Capacity BTU/h	EER BTU/W-h	Capacity BTU/h	COP	Capacity BTU/h	EER BTU/W-h	Capacity BTU/h	COP		
PSC	007	6,100	13.20	7,800	5.10	N/A				6,800	15.10	4,900	3.40	300	2.0
	009 Horizontal	8,150	12.40	10,700	4.70	N/A				8,700	14.40	6,900	3.20	300	2.5
	009 Vertical	8,150	12.40	10,700	4.70	N/A				8,700	14.40	6,900	3.20	330	2.5
	012 Horizontal	10,900	12.20	13,000	4.30	N/A				11,800	14.10	8,700	3.20	375	3.0
	012 Vertical	10,900	12.20	13,800	4.30	N/A				11,500	14.10	8,800	3.20	375	3.0
	015	14,200	12.80	16,100	4.40	N/A				14,200	14.60	11,300	3.30	500	4.0
	018	18,200	14.10	20,200	4.60	N/A				19,200	16.15	14,300	3.50	600	5.0
	024	24,300	14.20	27,400	5.00	N/A				25,400	16.90	18,100	3.55	800	6.0
	030	28,200	13.40	32,600	4.70	N/A				29,500	15.60	21,500	3.40	950	7.0
	036	36,900	14.30	38,800	4.65	N/A				38,500	16.65	27,100	3.55	1200	9.0
	041	36,000	14.15	39,100	4.45	N/A				37,400	16.20	27,400	3.30	1240	9.0
	042	39,600	13.65	42,800	4.45	N/A				41,200	15.90	30,000	3.25	1380	10.0
	048	46,200	13.95	58,600	4.65	N/A				48,400	16.35	39,300	3.40	1640	12.0
	060	59,100	13.60	77,800	4.80	N/A				61,600	15.80	53,400	3.75	1900	15.0
070	64,000	13.30	72,800	4.40	N/A				66,400	15.00	50,800	3.40	2000	16.0	
ECM	015	13,700	13.90	15,500	4.40	N/A				14,400	16.20	10,700	3.30	500	4.0
	018	18,500	14.50	19,900	4.70	N/A				19,500	16.95	14,000	3.55	650	5.0
	024	24,700	14.90	27,000	5.10	N/A				25,800	17.65	17,700	3.60	850	6.0
	030	28,800	13.50	32,000	4.90	N/A				30,100	15.65	20,900	3.55	950	7.0
	036	37,200	14.70	38,400	4.75	N/A				38,800	17.10	26,700	3.60	1200	9.0
	041	37,000	14.35	38,200	4.70	N/A				38,400	16.45	26,500	3.45	1240	9.0
	042	40,500	14.20	41,800	4.60	N/A				42,100	16.60	29,000	3.40	1380	10.0
	048	47,100	14.30	57,800	4.70	N/A				49,300	16.70	38,500	3.45	1640	12.0
	060	59,000	14.30	66,400	4.30	N/A				61,100	16.40	46,200	3.30	2000	15.0
	070	65,200	14.60	71,800	4.60	N/A				67,600	16.60	50,000	3.50	2100	16.0

NOTE(S):

- a. Ratings based upon ANSI/AHRI/ASHRAE/ISO 13256-1 with 1-in. disposable filter.
- b. For specific configuration ratings, refer to WSHP Builder in Carrier ECAT.
- c. Vertical/Horizontal airflow.
- d. Ground Loop Heat Pump ratings require an extended range option.
- e. Certified in accordance with ANSI/AHRI/ASHRAE/ISO 13256-1.

LEGEND

- AHRI — Air-Conditioning, Heating and Refrigeration Institute
- COP — Coefficient Performance
- EER — Energy Efficiency Ratio
- ISO — International Organization for Standardization
- N/A — Not Applicable



Physical Data — 50PCH,PCV (007-030) Units^a

50PCH,PCV UNIT	007	009	012	015	018	024	030	
COMPRESSOR (1 each)	Rotary						Scroll	
Maximum Water Working Pressure (psig)	400 ^b							
PSC Fan Motor and Blower	PSC							
Fan Motor Type	PSC							
Fan Motor (hp)	1/10			1/6		1/4		
Blower Wheel Size (Dia x W) (in.)	4.5 x 4.5		5.5 x 4.5		9 x 7			
Constant Torque and Constant Airflow Fan Motor and Blower	PSC							
Fan Motor Type	PSC			Constant Torque/Constant Airflow				
Fan Motor (hp)	1/10			1/3		1/3		
Blower Wheel Size (Dia x W) (in.)	4.5 x 4.5		5.5 x 4.5		9 x 7			
WATER CONNECTION SIZE FPT (in.)	3/4							
Coaxial Coil Volume (gal.)	0.06	Cu: 0.06 Cu/Ni: 0.08	0.08	0.09	0.14	0.24	0.24	
Condensate Connection in. FPT	3/4							
VERTICAL CABINET								
Typical Refrigerant Charge (oz)	16	19	Cu: 19/CuNi: 25	Cu: 19/CuNi: 17	Cu: 23/CuNi: 25	Cu: 35/CuNi: 33		
Air Coil Dimensions (H x W) (in.)	10 x 14			12 x 16.5	16 x 16.5	20 x 16.5		
Std. Filter - 1 in. Throwaway (L x H) (in.)	10 x 16			16 x 20		20 x 20		
Opt. Filter - 2 in. MERV 8 or 13 Throwaway (L x H)	10 x 16			16 x 20		20 x 20		
Weight - Operating (lb)	98	105	105	123	173	177	190	
Weight - Shipping (lb)	126	132	132	151	201	205	217	
HORIZONTAL CABINET								
Typical Refrigerant Charge (oz)	Cu: 16/CuNi:19		19	Cu: 19/CuNi:25	Cu: 19/CuNi:22	Cu: 24/CuNi:25	Cu: 35/CuNi: 33	
Air Coil Dimensions (H x W) (in.)	10 x 14			12 x 16.5	16 x 16.5	16 x 20.5		
Std. Filter - 1 in. Throwaway (L x H) (in.)	10 x 16			16 x 20		16 x 25		
Opt. Filter - 2 in. MERV 8 or 13 Throwaway (L x H) (in.)	10 x 16			16 x 20		16 x 25		
Weight - Operating (lb)	96	105	105	136	174	181	190	
Weight - Shipping (lb)	128	134	134	158	208	212	224	

Physical Data — 50PCH,PCV (036-070) Units^a

50PCH,PCV UNIT	036	041	042	048	060	070
COMPRESSOR (1 each)	Scroll					
Maximum Water Working Pressure (psig)	400 ^b					
PSC Fan Motor and Blower	PSC					
Fan Motor Type	PSC					
Fan Motor (hp)	1/2	3/4	1/2	3/4		
Blower Wheel Size (Dia x W) (in.)	9 x 7	10 x 8			10 x 9	11 x 9
Constant Torque and Constant Airflow Fan Motor and Blower	Constant Torque/Constant Airflow					
Fan Motor Type	Constant Torque/Constant Airflow					
Fan Motor (hp)	1/2	3/4			1	
Blower Wheel Size (Dia x W) (in.)	9 x 7	10 x 8			11 x 9	
WATER CONNECTION SIZE FPT (in.)	3/4			1		
Coaxial Coil Volume (gal.)	0.27			0.49	0.62	
Condensate Connection in. FPT	3/4					
VERTICAL CABINET						
Typical Refrigerant Charge (oz)	Cu: 44/CuNi: 40	41	47	52	59	64
Air Coil Dimensions (H x W) (in.)	24 x 20.2	20 x 16	24 x 20.2	24 x 26.75		32 x 26.2
Std. Filter - 1 in. Throwaway (L x H) (in.)	24 x 24	20 x 20	24 x 24	24 x 30		16 x 30 (2)
Opt. Filter - 2 in. MERV 8 or 13 Throwaway (L x H) (in.)	24 x 24	20 x 20	24 x 24	24 x 30		16 x 30 (2)
Weight - Operating (lb)	229	217	239	287	307	336
Weight - Shipping (lb)	255	243	265	312	331	360
HORIZONTAL CABINET						
Typical Refrigerant Charge (oz)	40	N/A	Cu: 43/CuNi: 42	51	62	61
Air Coil Dimensions (H x W) (in.)	18 x 27.5	N/A	18 x 27.5	20 x 32		20 x 42
Std. Filter - 1 in. Throwaway (L x H) (in.)	18 x 30	N/A	18 x 30	20 x 34.5		20 x 24 (2)
Opt. Filter - 2 in. MERV 8 or 13 Throwaway (L x H) (in.)	18 x 30	N/A	18 x 30	20 x 34.5		20 x 24 (2)
Weight - Operating (lb)	226	N/A	231	274	288	316
Weight - Shipping (lb)	270	N/A	264	299	318	365

NOTE(S):

- Refrigerant charges will depend on unit configuration and design revision.
- 300 psig when unit is built with the 2-way solenoid valve option.

LEGEND

- CA** — Constant Airflow
- CT** — Constant Torque
- ECM** — Electronically Commutated Motor
- FPT** — Female Pipe Thread
- PSC** — Permanent Split Capacitor
- TXV** — Thermostatic Expansion Valve

ITEM	FACTORY-INSTALLED OPTION	FIELD-INSTALLED ACCESSORY
Cupronickel Heat Exchanger	X	
Air Coil Protection	X	
Extended Range Units	X	
Hot Gas Reheat	X	
Hot Gas Bypass	X	
Waterside Economizer	X	
Sound Attenuation Package	X	
Constant Torque ECM	X	
Constant Airflow ECM	X	
Two-Position Water Valve	X	
Better B Control Package	X	
Complete C Control Package	X	
Deluxe D Control Package	X	
WSHP Open Multi-Protocol Controller	X	
WSHP Open Equipment Touch™ Device		X
WSHP Open System Touch™ Device		X
WSHP Open ZS Sensor		X
Supply and Return Water Hose Kits		X
Electric Duct Heaters		X
Carrier Non-Communicating Thermostat		X

Factory-installed options

Cupronickel heat exchangers

They are available for higher corrosion protection for applications such as open tower, geothermal, etc. Consult the water quality guidelines for proper application and selection of this option.

Air coil protection

This option offers tin electro-plated copper tubing with high-tech polymer coated aluminum fins will protect the air coil from all forms of corrosive elements in the airstream. Air coil protection is recommended for primary residence applications to protect against formicary corrosion.

Extended range units

This option insulates the coaxial coil to prevent condensation, and therefore potential dripping problems, in applications where the entering water temperature is below the normal operating range (less than 50°F). Units are capable of operating at a range of 25 to 110°F. Thermostatic expansion valves (TXVs) come with the optional extended range units and are designed to vary the flow of refrigerant depending on the load. The TXVs provide unit optimization and more stable control over a wider range of operating conditions.

Hot gas reheat (HGRH)

HGRH is an efficient and effective method of providing space humidity control. HGRH allows the unit to dehumidify the space when there is no demand for space cooling without the need for additional energy consuming devices.

The HGRH package is factory installed and includes a HGRH coil (installed behind the indoor air coil, a HGRH control valve, and additional refrigerant piping. The HGRH coil is factory sized to maximize performance.

When the space temperature is satisfied but the space humidity is above the desired set point, a call for

dehumidification is initiated and the unit fan, reversing valve, HGRH valve, and compressor are enabled. The fan draws in warm humid air through the indoor air coil where it is cooled and dehumidified. The cool, dehumidified air then passes through the reheat coil where it is heated to a neutral temperature (typically 68 to 78°F). The neutral, dry air is then delivered to the space and reduces space humidity levels without cooling the space. See WSHP Builder for HGRH performance.

Hot gas bypass

It prevents icing of the air coil when the unit is operating at low cooling load conditions. The hot gas bypass valve located in the compressor discharge line diverts hot gas to the inlet of the air coil. The valve is factory set to open when the evaporating pressure falls to 90 psig and will modulate to prevent the pressure falling any lower. This setting is field adjustable and this set point may be adjusted as required.

Waterside economizer

It is available and allows for free cooling for applications where the water loop temperature is able to reach temperatures between 40 and 65°F. When the loop is cold enough, the waterside economizer acts as a chilled water coil, providing free cooling without the use of the compressor (no mechanical cooling). The water leaving the economizer coil is then directed to the unit coaxial coil, which can allow compressor operation in integrated economizer cooling applications.

The factory-installed waterside economizer coil is mounted external to the air coil as shown below. The waterside economizer is controlled by the factory-supplied and installed Aquastat. The Aquastat is factory wired to the unit control board, and has a field adjustable range of -30°F to 100°F, with recommended settings of 45°F for cooling. A remote sensing bulb is stored inside the WSHP for shipping and requires field installation.

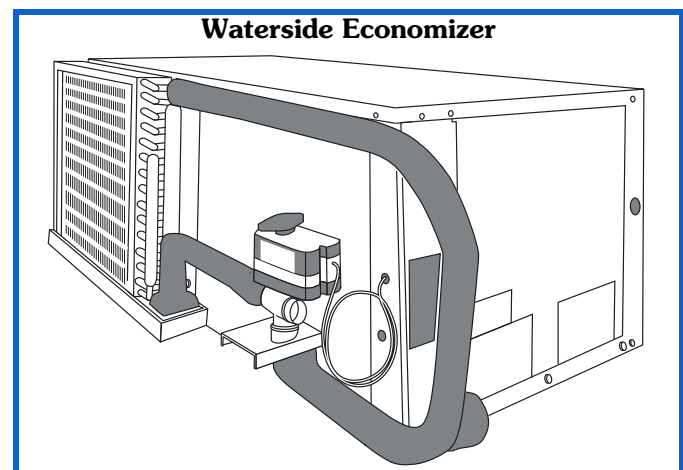

Water flow through the waterside economizer is controlled by a factory installed and wired 3-way motorized valve. When the waterside economizer is active (based on the Aquastat set point), flow is through the waterside economizer coil and then through the coaxial coil. When mechanical cooling is active (when the water loop temperature is outside the Aquastat set point), water flow is through the coaxial coil only.

Waterside economizer capacity and performance data can be seen in the WSHP Builder selection software.

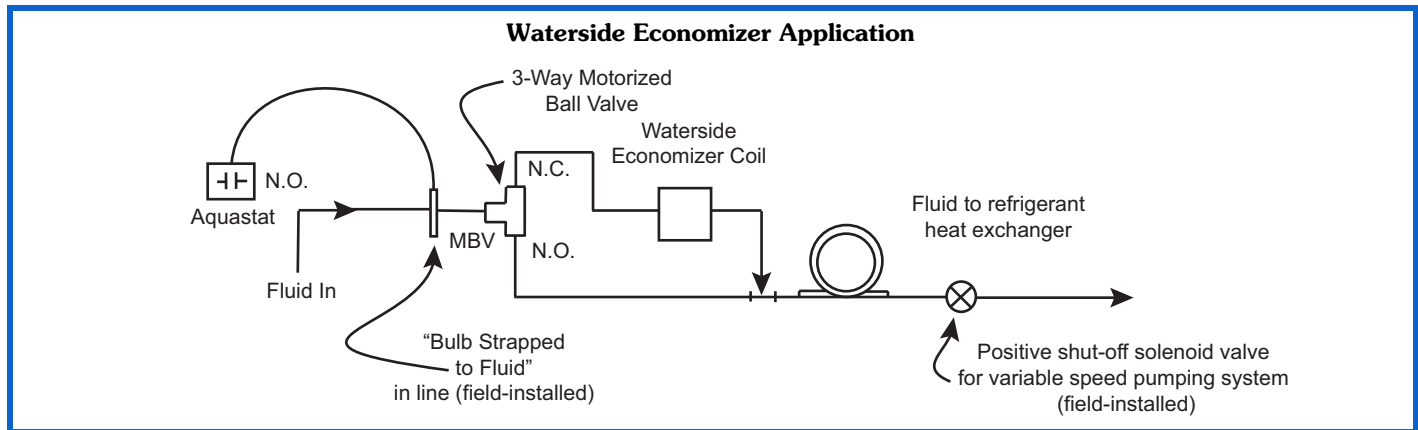

Sound attenuation packages (mute package or closed cell foam)

Available for applications that require especially low noise levels. With the mute package option, a compressor sound blanket is added to reduce compressor sound output. With the closed cell foam option, the entire unit cabinet is lined with high density closed cell foam insulation to reduce the fan and compressor sound output.

Constant Torque ECMs

Optional on sizes 015-070 and provide the efficiency and operability of an ECM at a lower cost than a constant airflow ECM. Constant torque ECMs provide 5 available motor speed taps and will maintain a constant motor torque as external static pressure in the system increases. As the system static pressure increases, reduction in fan airflow with a constant torque ECM is minor.

Constant Airflow ECM

Constant airflow ECMs are optional on sizes 015-070 and will maintain constant unit airflow as the static pressure in the system increases. Constant airflow ECMs provide 3 available speed settings. 460V/3 Ph units with constant airflow ECM motors require a four wire configuration (L1, L2, L3, N).

Two-position water valve

Optional on all unit sizes and is a great energy savings option. The valve opens to allow 100% fluid flow through the coaxial heat exchanger only when there is a call for cooling or heating. Closing off fluid flow to the unit

when there is no call for cooling or heating reduces system operating costs, when using variable speed pumping, by reducing the speed of the primary loop pumps.

Better B control package

The Better B control package provides most of the same capabilities as the Complete C control package and comes with a standard 75 va transformer. The Better B Package is not available with the WSE (waterside economizer) or HGRH (hot gas reheat) options. When the unit is built with WSE or HGRH, it will automatically come with the Complete C Package and an upgraded 75 va transformer as standard.

Deluxe D control package

Provides all of the options on the standard Complete C control package in addition to the following:

- Phase Monitor - Prevent motors from running at temperatures above approved ratings, and provides protection against phase loss, phase reversal, and phase imbalance.
- Boilerless Control - For use when the desired means of heating is an electric heater, and no boiler is installed in a water loop system.
- Energy Management Switch - Enables a 24 vac external signal to control the operation of the WSHP.
- Pump-Valve Relay - Provides a signal between an isolation valve and a secondary pump.
- Larger transformer - 75 va transformer.

Better B, Complete C, and Deluxe D Package Capabilities

CAPABILITY	BETTER B PACKAGE ^a	COMPLETE C PACKAGE	DELUXE D PACKAGE
High and Low Refrigerant Pressure Switches	X	X	X
Fluid Temperature (Freeze) Protection	X	X	X
Condensate Overflow Protection Sensor	X	X	X
Air Temperature (Freeze) Protection	X	X	X
Anti-Short Cycle Timer	X	X	X
Random Start Relay	X	X	X
Low Pressure Bypass Timer	X	X	X
Surge Protection	X	X	X
Intelligent Reset	X	X	X
Lockout Reset	X	X	X
Malfunction (Alarm) Output	X	X	X
Test Service Mode with LED Fault Indication	X	X	X
Dehumidification Control via Hot Gas Reheat		X	X
Waterside Economizer Control		X	X
Transformer	75 va	50 va ^b	75 va
Field Installed DDC Controller	X	X	X
Phase Monitor (3-phase Units Only)			X
Boilerless Control			X
Energy Management Switch			X
Pump-Valve Relay			X

NOTE(S):

a. Better B Package not available with the waterside economizer or HGRH (hot gas reheat) options.

b. With HGRH (hot gas reheat), waterside economizer or factory-installed DDC (direct digital controls), the WSHP will have a 75 va transformer.

WSHP Open controller

Continuously monitors and regulates water source heat pump operation with reliability and precision. This advanced controller features a sophisticated, factory-engineered control program that provides optimum performance and energy efficiency.

The WSHP Open controller is factory installed and programmed to control all factory-installed standard options including hot gas reheat and waterside economizer as well as provide boilerless electric heat control and demand controlled ventilation.

The WSHP Open controller is programmed to communicate with different protocols including BACnet¹, N2², Modbus³ and LonWorks⁴. While the controller is programmed to operate on Carrier's i-Vu[®] building automation system (BAS), the WSHP Open can easily be integrated into a third party BAS.

NOTE: A separate LON integration card is required for LonWorks.

Independent three-speed fan control

It provides the most efficient WSHP operation. All WSHP Open controllers come programmed from the factory with 3-speed fan control, with user selectable low, medium and high fan speeds. Using the space temperature input, the WSHP Open controller will automatically operate the fan at the optimal speed to maintain space temperature while providing increased latent heat removal, reduced sound and the lowest fan energy consumption.

Three-speed fan control is available only with constant torque ECM and PSC fan motors.

1. BACnet is a trademark of ASHRAE.
2. N2 Intuitive fault detection.
3. Modbus is a registered trademark of Schneider Electric.
4. LonWorks is a registered trademark of Echelon Corporation.

Allows prolonged operation of the WSHP. The pre-programmed WSHP Open controller logic monitors and preemptively shuts down a WSHP as an alarming condition approaches instead of causing a hard lockout of the WSHP. This way, the WSHP can automatically restart if the fault condition clears within a set amount of time and a local reset of the WSHP is not required.

Learning adaptive optimal start

It transitions the WSHP from unoccupied set points to occupied set points in the most efficient means possible. Over time, the WSHP will learn and determine the best adjustment rates of the set points to provide the most efficient means of shifting the WSHP to an occupied mode.

Field-installed accessories

WSHP Open Equipment Touch™ and System Touch™

These touchscreen devices have a color LCD display that allows easy connection to the controllers to view or change the controller's property values including set points, schedule equipment, view trends and alarms and more. The Equipment Touch device provides easy connection to one controller while the System Touch device can access up to 60 controllers when wired together as a network. For more details about the Equipment Touch and System Touch devices, see either the Equipment Touch or System Touch Installation and Setup Guide.

WSHP Open

ZS sensors are the preferred method of monitoring space temperature, humidity and CO₂ levels when using the WSHP Open controller.

NOTE: The ZS sensor is required for space temperature with all WSHP Open controllers. Only a ZS sensor can provide the necessary space temperature input for the WSHP Open controller.

ZS Sensor Features

FEATURES	ZS STANDARD	ZS PLUS	ZS PRO	ZS PRO-F
Temp, CO ₂ , Humidity	X	X	X	X
Neutral Color	X	X	X	X
Addressable/Supports Daisy-Chaining	X	X	X	X
Hidden Communication Port	X	X	X	X
Mounts on a Standard 2-in. X 4-in. Electrical Box	X	X	X	X
Occupancy Status Indicator		X	X	X
Push-Button Occupancy Override		X	X	X
Set Point Adjust		X	X	X
Large, Easy-to-Read LCD			X	X
Alarm Indicator			X	X
Fan Speed Control				X
Cooling/Heating/Fan Only - Mode Control				X
F to C Conversion Button				X

ZS Sensor Options

OPTIONS	ZS STANDARD	ZS PLUS	ZS PRO	ZS PRO-F
	Part Number			
Temperature Only	ZS2-CAR	ZS2PL-CAR	ZS2P-CAR	ZS2PF-CAR
Temperature with CO ₂	ZS2-C-CAR	ZS2PL-C-CAR	ZS2P-C-CAR	ZS2PF-C-CAR
Temperature with Humidity	ZS2-H-CAR	ZS2PL-H-CAR	ZS2P-H-CAR	ZS2PF-H-CAR
Temperature with Humidity and CO ₂	ZS2-HC-CAR	ZS2PL-HC-CAR	ZS2P-HC-CAR	ZS2PF-HC-CAR

Supply and return water hose kits

Available as accessories. Hose kits are recommended for connection between the unit and the water loop piping. Hose kits are 24 inches in length, flexible stainless steel and have options for manual isolation valves with and without autoflow regulators and Y-strainers.

Electric duct heaters

Available ranging from 5 to 20 kW of electric heat in all available WSHP voltages. These slip-in type heaters provide an extra means of auxiliary heat or reheat control.

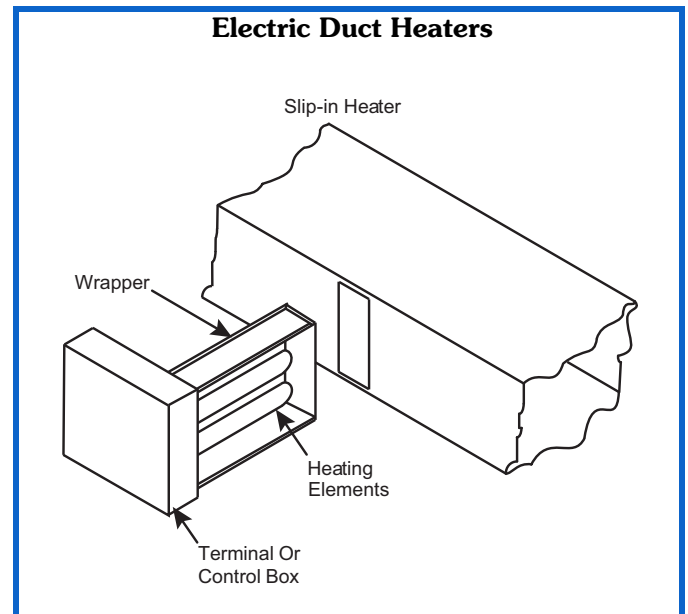

Carrier Thermostat Options

THERMOSTAT TYPE	MODEL	DESCRIPTION
BACNET	Comfortvu BACnet Plus (TBPL-24-H-C / TBPL-24-HM-C)	<ol style="list-style-type: none"> 24 VAC controller with combination space temperature, relative humidity, and motion sensors (temperature, humidity only on TBPL-24-C). Large touch screen backlit display, 7-day scheduling, demand response, remote sensor capability, dry contact. BACnet MS/TP, 1-3 stage heat, 1-2 stage cool, 1-3 fan speeds, WSE, HGRH, HP.
	Comfortvu BACnet (TB-24-C / TB-24-HM-C)	
WIFI	Connect BACnet Wi-Fi (33CONNECTSTAT43)	<ol style="list-style-type: none"> 24 VAC controller with on-board space temperature and relative humidity sensor. Large touch screen LCD display, 7-day scheduling, demand response, remote sensor capability. BACnet MS/TP (33CONNECTSTAT43 only), up to 4 stage heat, up to 3 stage cool, WSE, HP.
	Connect Wi-Fi (33CONNECTSTAT)	
PROGRAMMABLE/ NON PROGRAMMABLE	Edge Pro (33CS2PP2S-03 / 33CS2PPRH-03)	<ol style="list-style-type: none"> 24 VAC programmable control with on-board temperature and humidity (temperature only on 33CS2PP2S-03). Backlit display 7-Day Programmable/Non-Programmable, 2-stage Heat/2-stage Cool, HP (with emergency heat). <p>OR</p> <p>G/E, Dry Contact, Remote Sensor Capability, Pre-Occupancy Purge, Soft Start, Manual/Auto-Changeover, and Bypass Damper Output</p>
	Comfort Pro (33CSCNACHP-01/ 33CSCPACHP-01)	

See Carrier Thermostat Product Data for further details.

50PCH Unit

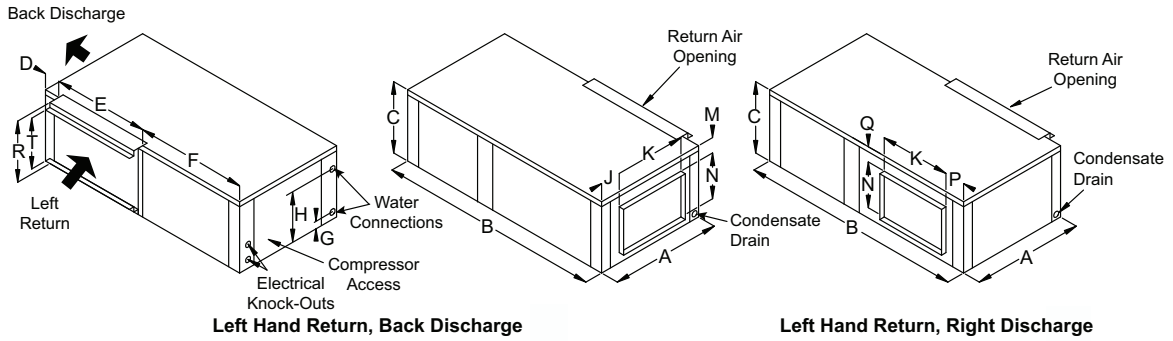

NOTE: Models 048 and 060 Left Hand Return units have condenser water connections on the front right and electrical knockouts on the front left.

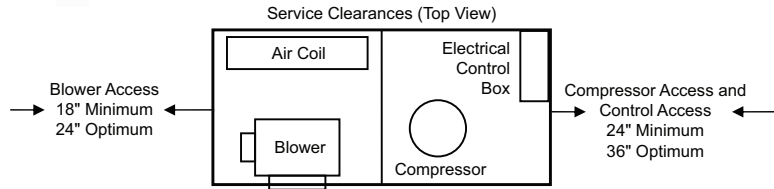
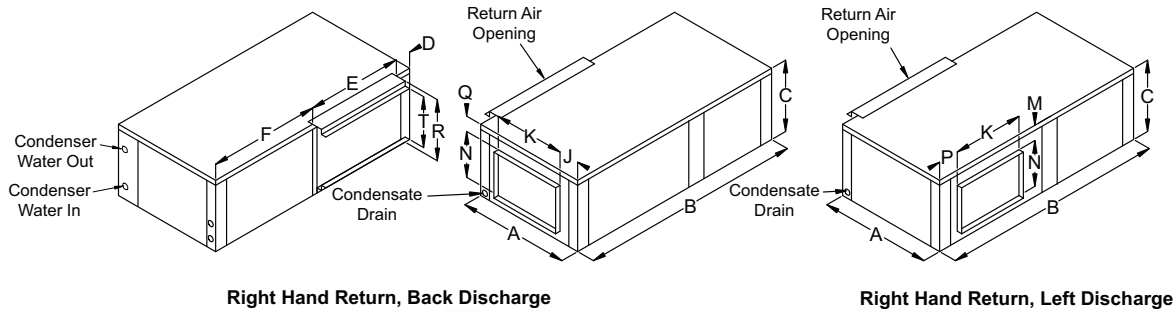

LEGEND
R/A — Return Air

50PCH007-070 Units

50PCH UNIT SIZE	A	B	C	D	E	F	G	H	J	K	M	N	P	Q	R	T	CONDENSER WATER CONNECTIONS FPT	RECOMMENDED REPLACEMENT NOMINAL FILTER SIZE
	WIDTH*	DEPTH†	HEIGHT	CAB END TO FILTER RACK	R/A DUCT WIDTH	CAB FRONT TO FILTER RACK	WATER INLET	WATER OUTLET	SIDE TO DISC. WIDTH	DISC. WIDTH	TOP TO DISC.	DISC. HEIGHT	END TO DISC.	TOP TO DISC.	FILTER RACK HEIGHT	R/A DUCT FLANGE HEIGHT		
007	19.0	33.0	11.5	1.5	16.15	15.35	2.38	9.50	5.375	6.30	5.97	4.10	4.875	1.41	11.3	8.6	3/4	10x16x1
009	19.0	33.0	11.5	1.5	16.15	15.35	2.38	9.50	5.375	6.30	5.97	4.10	4.875	1.41	11.3	8.6	3/4	10x16x1
012	19.0	33.0	11.5	1.5	16.15	15.35	2.38	9.50	5.250	6.43	6.31	4.10	4.750	1.14	11.3	8.6	3/4	10x16x1
015	22.0	43.0	17.0	1.5	20.15	21.35	2.86	15.00	8.150	6.43	9.55	4.10	7.650	3.40	16.8	15.0	3/4	16x20x1
015**	22.0	43.0	17.0	1.5	20.15	21.35	2.86	15.00	5.420	9.13	6.11	9.65	4.920	1.23	16.8	15.0	3/4	16x20x1
018	22.0	43.0	17.0	1.5	20.15	21.35	2.86	14.13	5.420	9.13	6.11	9.65	4.920	1.23	16.8	15.0	3/4	16x20x1
024	22.0	43.0	18.0	1.5	25.00	16.50	2.86	14.13	5.420	9.13	6.11	9.65	4.920	1.23	16.8	15.0	3/4	16x25x1
030	22.0	43.0	18.0	1.5	25.00	16.50	2.47	15.00	5.420	9.13	6.11	9.65	4.920	1.23	16.8	15.0	3/4	16x25x1
036	22.0	54.5	19.0	1.5	30.15	22.85	2.86	16.13	6.470	9.13	7.50	10.28	5.970	1.21	18.8	17.0	3/4	18x30x1
042	22.0	54.5	19.0	1.5	30.15	22.85	2.86	16.13	5.270	10.45	6.46	11.30	4.770	1.22	18.8	17.0	3/4	18x30x1
048	25.0	54.5	21.0	1.5	34.60	18.40	2.86	18.52	7.250	10.45	7.46	11.36	6.750	2.16	20.8	19.0	1	20x34.5x1
060	25.0	54.5	21.0	1.5	34.60	18.40	2.86	18.52	6.320	11.76	6.81	12.50	5.820	1.68	20.8	19.0	1	20x34.5x1
070	25.0	65.0	21.0	1.5	48.10	15.40	2.86	18.52	6.320	11.76	6.81	12.50	5.820	1.68	20.8	19.0	1	20x24x1 (2)

* When waterside economizer is installed, increase width by 7 inches.
 † When WSHP Open Controller is installed, increase depth by 2.6 inches. When waterside economizer is installed, increase depth by 7 inches.
 ** 50PCH015 units built with ECM motor option.

- NOTES:
1. All dimensions are within ± 0.125 in.
 2. All condensate drain connections are 3/4 in. FPT.
 3. Unit sizes 015-070 can be field converted between end blow and straight through supply air configurations.
 4. Specifications subject to change without notice.
 5. The 1-in. filter rack extends 1.23 in. beyond the side of the unit. The 2-in. filter rack extends 2.89 in. beyond the side of the unit. The 2-in. filter rack is 4-sided with a filter access door on one end and can accept either a 1-in. or 2-in. filter.
 6. Return and discharge orientations determined when facing panel with water connections.

50PCV Unit

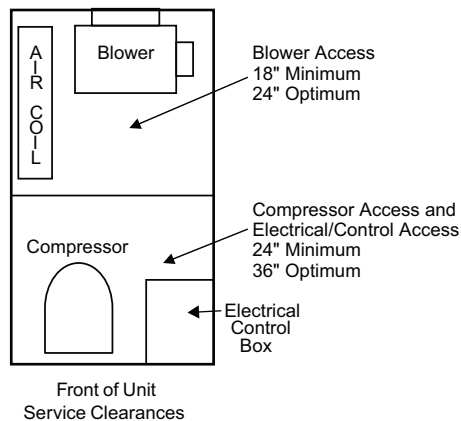
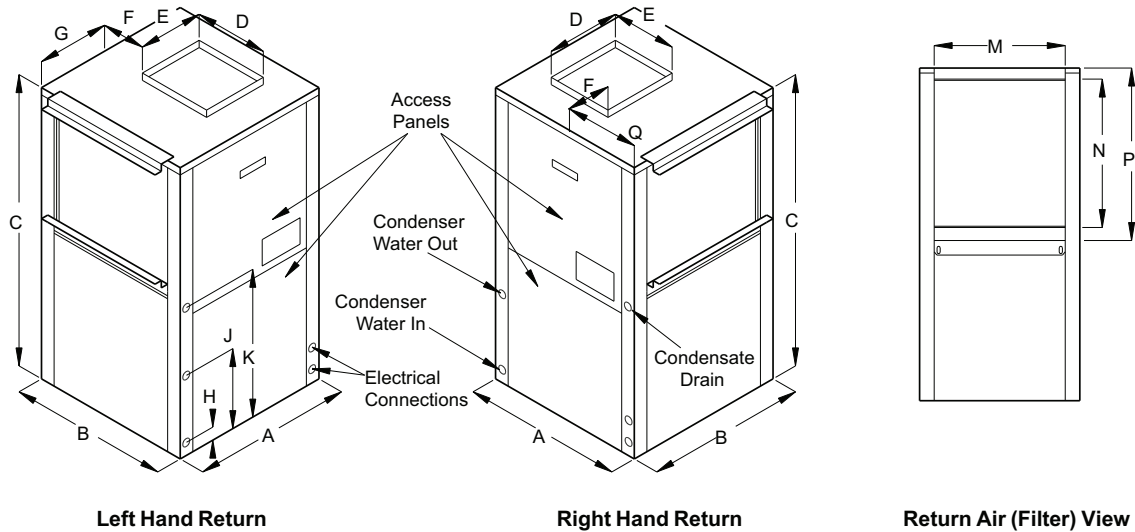

LEGEND

R/A — Return Air

50PCV007-070 Units

50PCV UNIT SIZE	A	B	C	D	E	F	G	H	J	K	M	N	P	Q	CONDENSER WATER CONNECTIONS FPT	RECOMMENDED REPLACEMENT NOMINAL FILTER SIZE
	WIDTH*	DEPTH†	HEIGHT	DISC. DEPTH	DISC. WIDTH	CABINET EDGE TO DISC.	LEFT SIDE TO DISC.	WATER INLET	WATER OUTLET	CONDENSATE DRAIN	R/A DUCT WIDTH	R/A DUCT FLANGE HEIGHT	FILTER RACK HEIGHT			
007	19.0	19.00	24.25	10.0	8.0	4.5	9.3	2.44	9.68	13.87	16.0	8.0	10.0	5.4	3/4	10x16x1
009	19.0	19.00	24.25	10.0	8.0	4.5	9.3	2.44	9.68	13.87	16.0	8.0	10.0	5.4	3/4	10x16x1
012	19.0	19.00	24.25	10.0	8.0	4.5	9.3	2.44	9.68	13.87	16.0	8.0	10.0	5.4	3/4	10x16x1
015	21.5	21.50	32.25	10.0	8.0	5.8	10.0	2.85	8.45	15.87	20.0	14.0	16.0	3.5	3/4	16x20x1
015**	21.5	21.50	32.25	14.0	14.0	3.1	5.2	2.85	8.45	15.87	20.0	14.0	16.0	5.2	3/4	16x20x1
018	21.5	21.50	32.25	14.0	14.0	3.1	5.2	2.85	8.45	15.87	20.0	14.0	16.0	5.2	3/4	16x20x1
024	21.5	21.50	39.25	14.0	14.0	3.1	5.2	2.80	8.45	18.87	20.0	18.0	20.0	5.2	3/4	20x20x1
030	21.5	21.50	39.25	14.0	14.0	3.1	5.2	2.80	8.45	18.87	20.0	18.0	20.0	5.2	3/4	20x20x1
036	21.5	26.00	43.25	16.0	14.0	4.0	5.0	2.75	10.77	18.87	24.0	22.0	24.0	5.0	3/4	24x24x1
041	21.5	21.50	40.25	16.0	14.0	1.7	4.7	2.80	8.45	18.87	20.0	18.0	20.0	4.7	3/4	20x20x1
042	21.5	26.00	44.25	16.0	14.0	4.0	5.0	2.75	10.77	18.87	24.0	22.0	24.0	5.0	3/4	24x24x1
048	24.0	32.50	45.25	18.0	14.0	7.0	6.2	3.26	13.20	20.87	30.0	22.0	24.0	6.2	1	24x30x1
060	24.0	32.50	45.25	18.0	14.0	7.0	6.2	3.26	13.20	20.87	30.0	22.0	24.0	6.2	1	24x30x1
070	26.0	33.25	58.25	18.0	16.0	7.8	7.2	2.92	13.36	25.87	30.0	30.0	32.0	7.2	1	16x30x1 (2)

* When waterside economizer is installed, increase width by 7 inches for Left Hand Return Units, increase width by 12 inches for Right Hand Return Units
 † When WSHP Open Controller is installed, increase depth by 2.6 inches. When Waterside economizer is installed, increase depth by 7 inches.
 ** 50PCV015 units built with ECM motor option.

NOTES:

1. All dimensions are within ± 0.125 inch.
2. All condensate drain connections are 3/4 in. FPT.
3. Specifications subject to change without notice.
4. The 1-in. filter rack extends 1.23 in. beyond the side of the unit. The 2-in. filter rack extends 2.89 in. beyond the side of the unit. The 2-in. filter rack is 4 sided with a filter access door on one end and can accept either a 1-in. or 2-in. filter.
5. Return and discharge orientations determined when facing panel with water connections.
6. The local electric codes may require 36 in. or more clearance at the electrical control box.

50PCV with Factory-Installed Disconnect Right Return

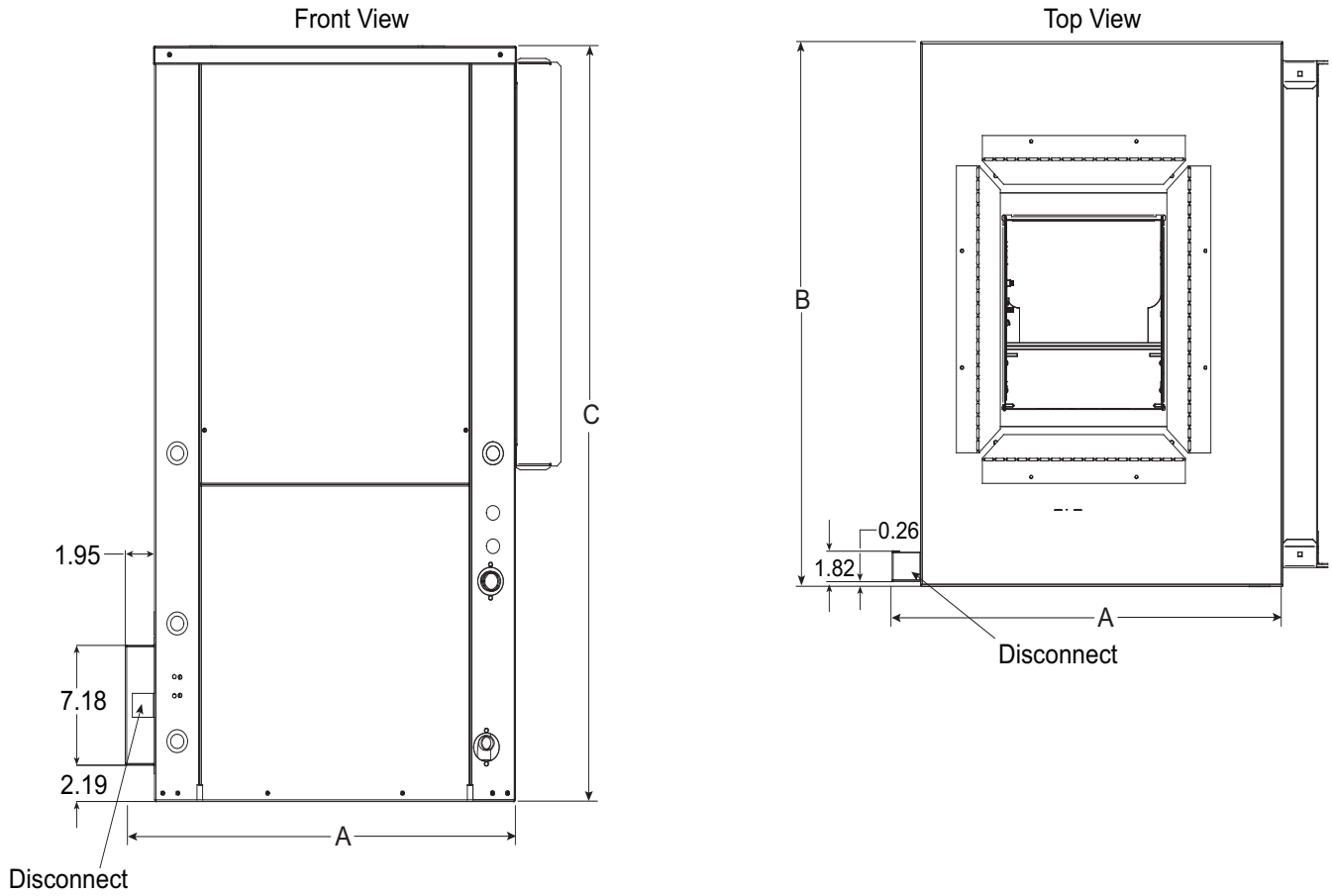

50PCV007-070 Units

50PCV UNIT SIZE	A	B	C
	Width	Depth*	Height
007	20.95	19.00	24.25
009	20.95	19.00	24.25
012	20.95	19.00	24.25
015	23.45	21.50	32.25
018	23.45	21.50	32.25
024	23.45	21.50	39.25
030	23.45	21.50	39.25
036	23.45	26.00	43.25
041	21.50	21.50	39.25
042	23.45	26.00	43.25
048	25.95	32.50	45.25
060	25.95	32.50	45.25
070	27.95	33.25	58.25

* If WSHP Open Controller is factory-installed, increase depth by 2.6 inches.

NOTE: Dimensions are shown in inches.

50PCV with Factory-Installed Disconnect Left Return

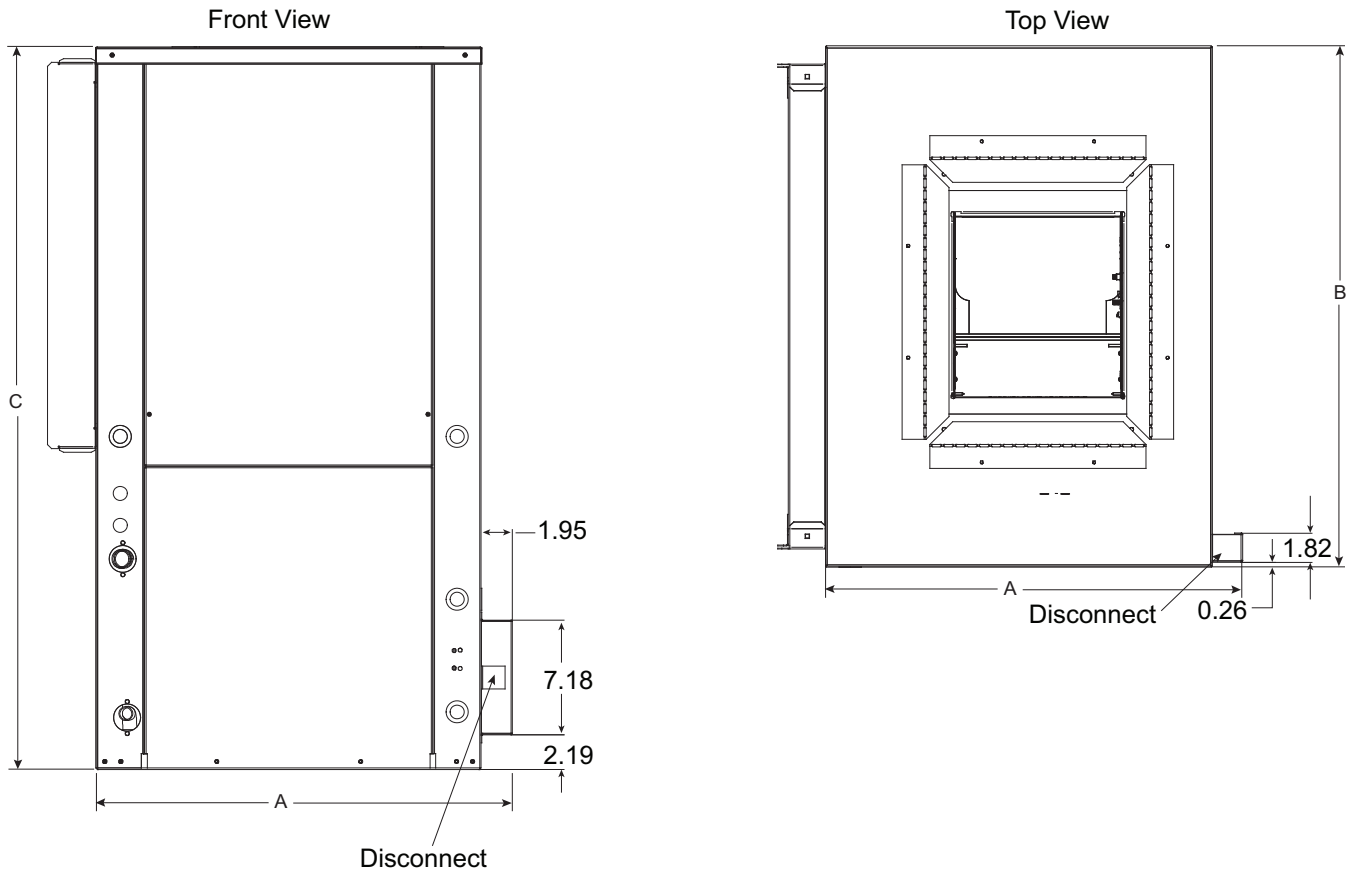

50PCV007-070 Units

50PCV UNIT SIZE	A	B	C
	Width	Depth*	Height
007	20.95	19.00	24.25
009	20.95	19.00	24.25
012	20.95	19.00	24.25
015	23.45	21.50	32.25
018	23.45	21.50	32.25
024	23.45	21.50	39.25
030	23.45	21.50	39.25
036	23.45	26.00	43.25
041	21.50	21.50	39.25
042	23.45	26.00	43.25
048	25.95	32.50	45.25
060	25.95	32.50	45.25
070	27.95	33.25	58.25

* If WSHP Open Controller is factory-installed, increase depth by 2.6 inches.

NOTE: Dimensions are shown in inches.

50PCV with Waterside Economizer Top View; Right Return

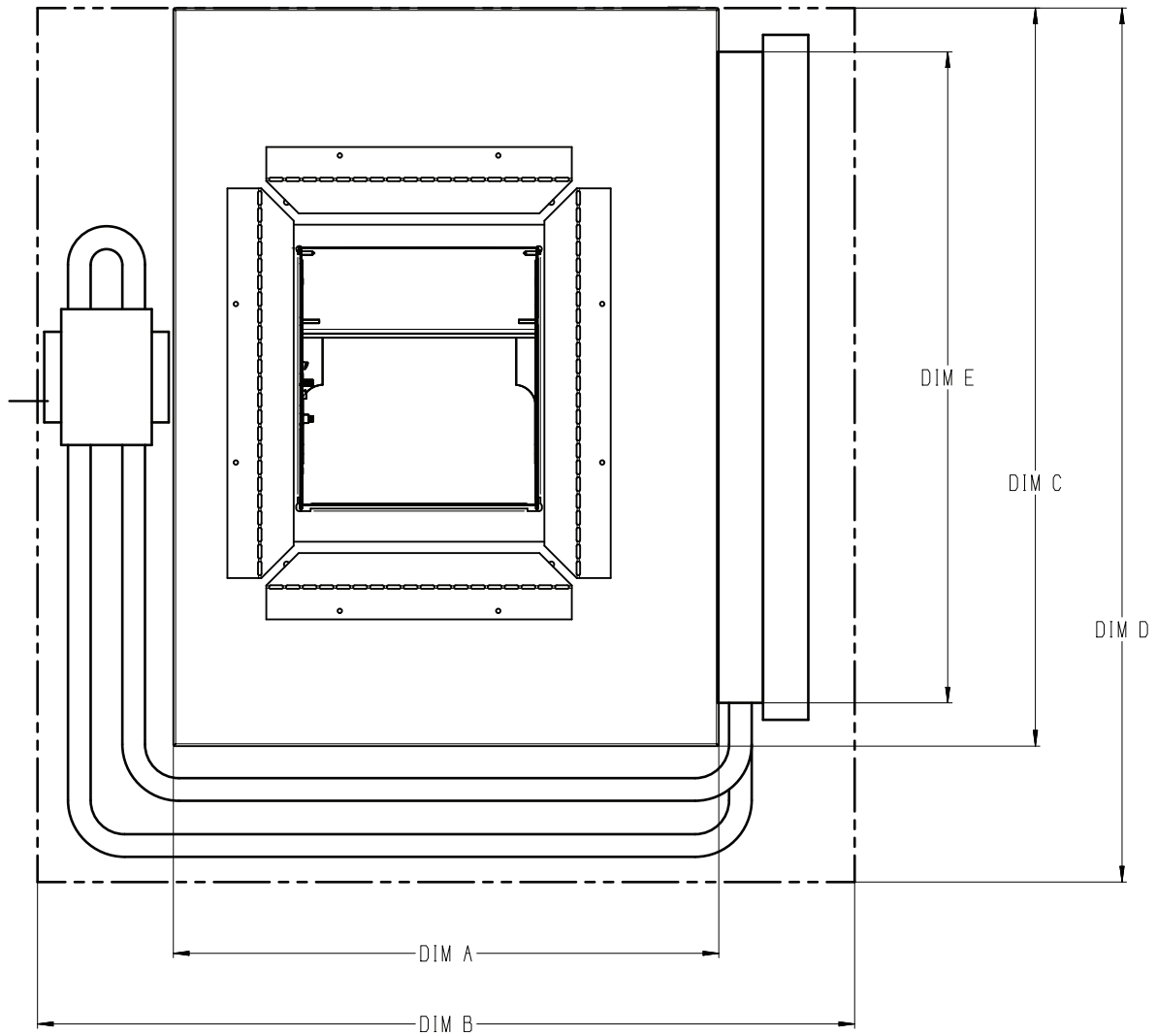

50PCV007-070 Units

50PCV UNIT SIZE	A	B	C	D	E	HEIGHT
	WIDTH UNIT	WIDTH ECO OPT	DEPTH UNIT	DEPTH ECO OPT	WIDTH ECO COIL	
007	19.00	31.00	19.00	25.00	14.00	24.25
009	19.00	31.00	19.00	25.00	14.00	24.25
012	19.00	31.00	19.00	25.00	14.00	24.25
015	21.50	33.50	21.50	27.50	16.50	32.25
018	21.50	33.50	21.50	27.50	16.50	32.25
024	21.50	33.50	21.50	27.50	16.50	39.25
030	21.50	33.50	21.50	27.50	16.50	39.25
036	21.50	33.50	26.00	32.00	21.00	43.25
041	21.50	33.50	21.50	27.50	16.50	39.25
042	21.50	33.50	26.00	32.00	16.50	43.25
048	24.00	38.00	32.50	39.50	27.00	45.25
060	24.00	38.00	32.50	39.50	27.00	45.25
070	26.00	40.00	33.25	40.25	27.00	58.25

LEGEND

ECO— Economizer
OPT— Option

NOTES:

1. Economizer height is the same as the unit height.
2. Dimensions are in inches.

50PCV with Waterside Economizer Top View; Left Return

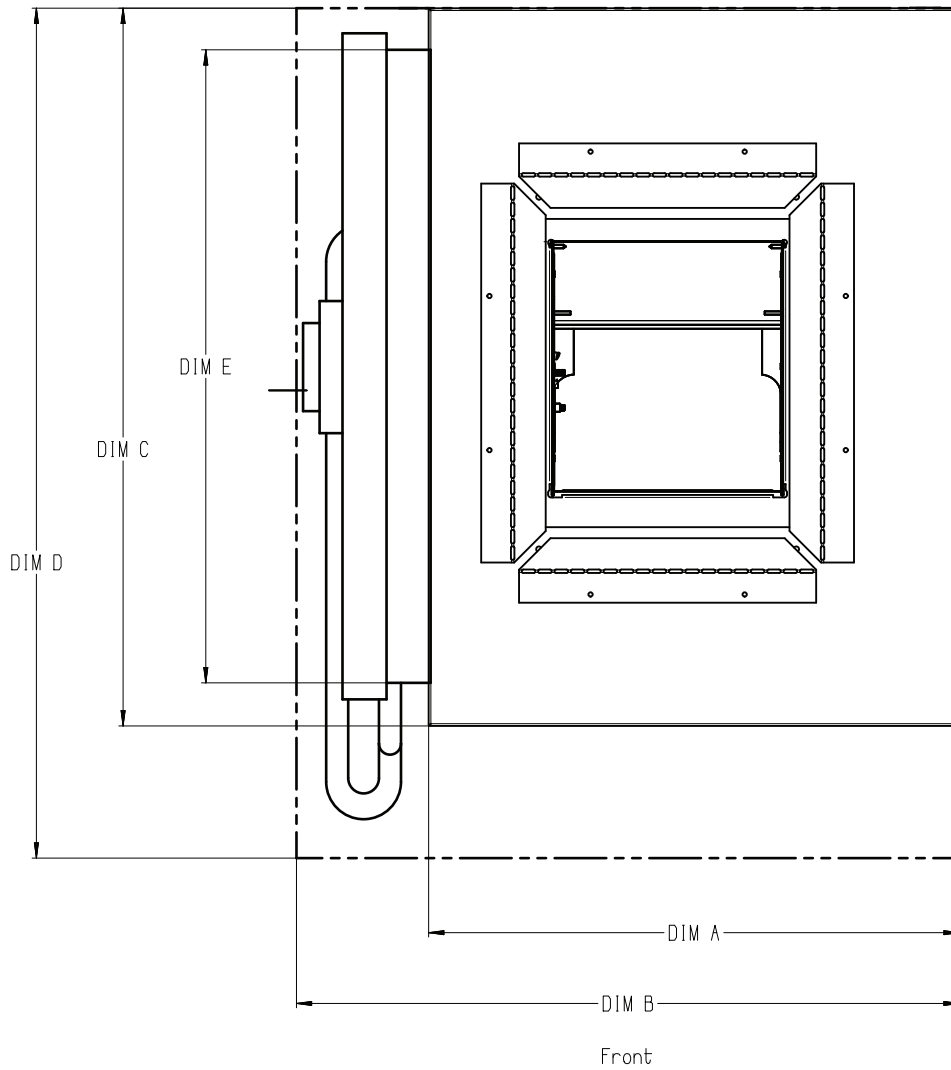

50PCV007-070 Units

50PCV UNIT SIZE	A	B	C	D	E	HEIGHT
	WIDTH UNIT	WIDTH ECO OPT	DEPTH UNIT	DEPTH ECO OPT	WIDTH ECO COIL	
007	19.00	25.00	19.00	25.00	14.00	24.25
009	19.00	25.00	19.00	25.00	14.00	24.25
012	19.00	25.00	19.00	25.00	14.00	24.25
015	21.50	27.50	21.50	27.50	16.50	32.25
018	21.50	27.50	21.50	27.50	16.50	32.25
024	21.50	27.50	21.50	27.50	16.50	39.25
030	21.50	27.50	21.50	27.50	16.50	39.25
036	21.50	27.50	26.00	32.00	21.00	43.25
041	21.50	27.50	21.50	27.50	16.50	39.25
042	21.50	27.50	26.00	32.00	16.50	43.25
048	24.00	31.00	32.50	39.50	27.00	45.25
060	24.00	31.00	32.50	39.50	27.00	45.25
070	26.00	33.00	33.25	40.25	27.00	58.25

LEGEND

ECO — Economizer
OPT — Option

NOTES:

1. Economizer height is the same as the unit height.
2. Dimensions are in inches.

50PCH with Waterside Economizer Top View; Right Return

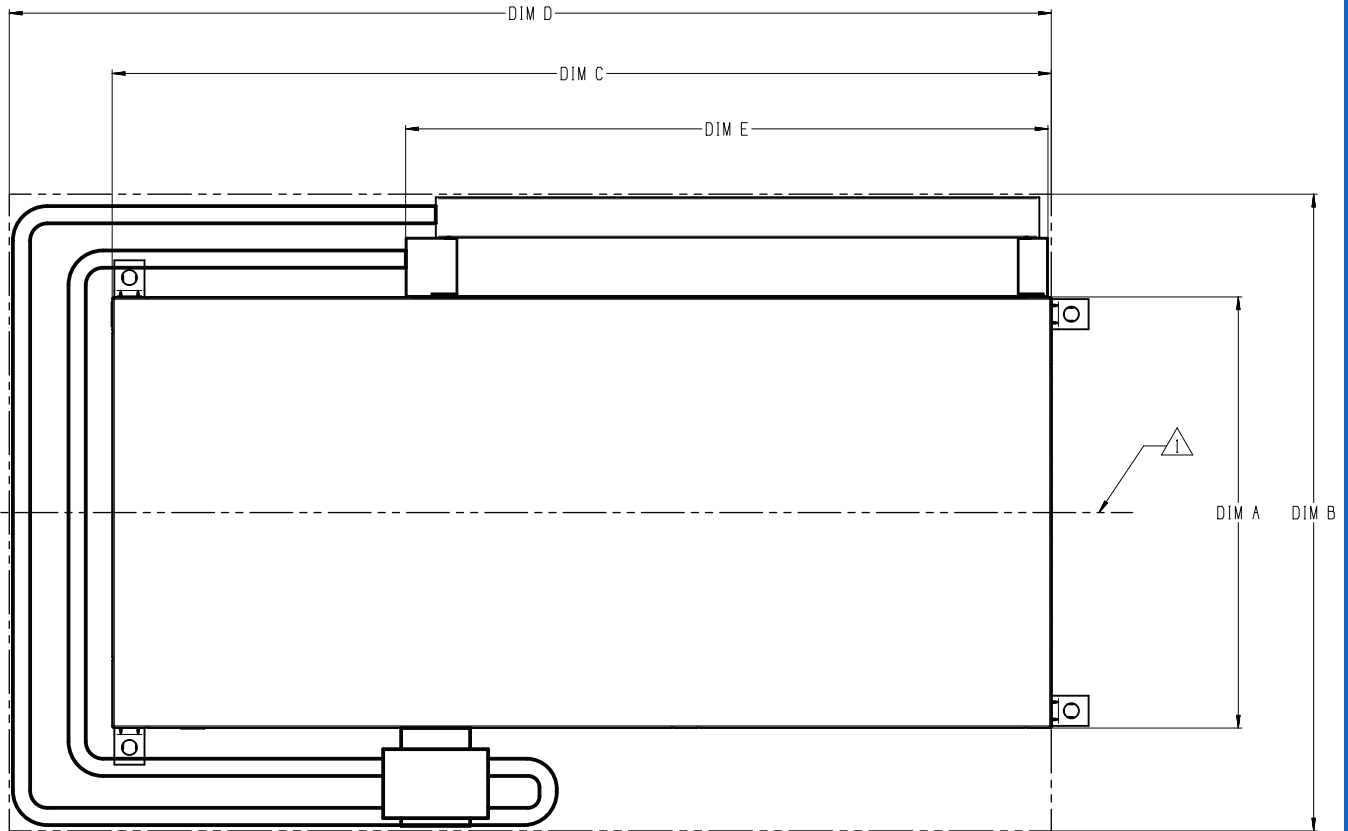

50PCH007-070 Units

50PCV UNIT SIZE	A	B	C	D	E	HEIGHT
	WIDTH UNIT	WIDTH ECO OPT	DEPTH UNIT	DEPTH ECO OPT	WIDTH ECO COIL	
007	19.00	31.00	33.00	39.00	14.00	11.50
009	19.00	31.00	33.00	39.00	14.00	11.50
012	19.00	31.00	33.00	39.00	14.00	11.50
015	22.00	34.00	43.00	49.00	16.50	17.00
018	22.00	34.00	43.00	49.00	16.50	17.00
024	22.00	34.00	43.00	49.00	20.50	17.00
030	22.00	34.00	43.00	49.00	20.50	17.00
036	22.00	34.00	54.50	60.50	28.00	19.00
042	22.00	34.00	54.50	60.50	28.00	19.00
048	25.00	39.00	54.50	61.50	43.20	21.00
060	25.00	39.00	54.50	61.50	43.20	21.00
070	26.00	33.00	65.00	72.00	43.20	21.00

LEGEND

ECO — Economizer
OPT — Option

NOTES:

1. Economizer height is the same as the unit height.
2. Dimensions are in inches.

50PCH007-070 Corner Weights (lb)

UNIT SIZE	TOTAL (lb)	LEFT HAND EVAPORATOR				RIGHT HAND EVAPORATOR			
		Left Front ^a	Right Front ^a	Left Back	Right Back	Left Front ^a	Right Front ^a	Left Back	Right Back
007	98	28	21	25	24	21	28	24	25
009	103	29	23	26	25	23	29	25	26
012	105	29	24	26	26	24	29	26	26
015	127	36	28	34	29	28	36	29	34
018	177	57	36	48	37	36	57	37	48
024	181	58	37	48	38	37	58	38	48
030	194	61	41	52	41	41	61	41	52
036	237	71	49	66	52	49	71	52	66
042	231	70	47	64	50	47	70	50	64
048	268	87	60	62	60	60	87	60	62
060	288	88	65	69	66	65	88	66	69
070	316	98	72	76	70	72	98	70	76

NOTE(S):

- a. Front is control box end.

Please see the WSHP Builder for cooling and heating performance data.

Antifreeze Correction Table

ANTIFREEZE TYPE	ANTIFREEZE%	COOLING			HEATING		WPD CORRECTION FACTOR
		EWT 90°F			EWT 30°F		
		Total Capacity	Sensible Capacity	kW	Heating Capacity	kW	EWT 30°F
Water	0	1.000	1.000	1.000	1.000	1.000	1.000
Propylene Glycol	5	0.997	0.997	1.004	0.989	0.997	1.060
	10	0.994	0.994	1.006	0.986	0.995	1.125
	15	0.990	0.990	1.009	0.978	0.988	1.190
	25	0.983	0.983	1.016	0.960	0.979	1.300
	30	0.979	0.979	1.020	0.950	0.974	1.736
	35	0.975	0.974	1.024	0.940	0.969	1.834
Methanol	5	0.997	0.997	1.003	0.990	0.997	1.060
	10	0.996	0.996	1.005	0.979	0.993	1.100
	15	0.994	0.994	1.008	0.970	0.990	1.140
	20	0.992	0.992	1.011	0.961	0.987	1.248
Ethanol	5	0.998	0.998	1.002	0.981	0.994	1.160
	10	0.996	0.996	1.004	0.960	0.988	1.230
	15	0.992	0.992	1.006	0.944	0.983	1.280
	25	0.986	0.986	1.009	0.917	0.974	1.400
Ethylene Glycol	5	0.997	0.997	1.003	0.993	0.998	1.060
	10	0.995	0.995	1.004	0.986	0.996	1.120
	15	0.992	0.992	1.005	0.980	0.993	1.190
	25	0.988	0.988	1.009	0.970	0.990	1.330
	30	0.985	0.985	1.012	0.965	0.987	1.400

LEGEND

EWT — Entering Water Temperature
WPD — Water Pressure Differential

50PCH,PCV (007-070) Blower Performance — Standard PSC Unit^a

50PCH, PCV	RATED AIRFLOW	FAN SPEED	AIRFLOW (cfm) AT EXTERNAL STATIC PRESSURE (in. wg)											
			0.10	0.20	0.30	0.40	0.50	0.60	0.70	0.80	0.90	1.00	1.10	1.20
007	300	Low	370	340	295	250	—	—	—	—	—	—	—	—
		Med	390	360	330	300	260	—	—	—	—	—	—	—
		High	410	380	350	315	280	210	—	—	—	—	—	—
009	350	Low	370	340	295	250	—	—	—	—	—	—	—	—
		Med	390	360	330	300	260	—	—	—	—	—	—	—
		High	410	380	350	315	280	210	—	—	—	—	—	—
012	400	Low	300	290	290	300	—	—	—	—	—	—	—	—
		Med	380	380	360	330	290	—	—	—	—	—	—	—
		High	420	400	380	360	340	320	—	—	—	—	—	—
015	500	Low	500	450	400	—	—	—	—	—	—	—	—	—
		Med	560	520	480	430	400	—	—	—	—	—	—	—
		High	700	650	600	550	500	450	400	—	—	—	—	—
018	600	Low	630	590	560	—	—	—	—	—	—	—	—	—
		Med	810	790	760	730	680	590	—	—	—	—	—	—
		High	1010	970	920	870	800	680	530	—	—	—	—	—
024	800	Low	740	730	700	660	610	—	—	—	—	—	—	—
		Med	830	810	770	730	680	620	—	—	—	—	—	—
		High	1000	950	900	830	750	690	630	—	—	—	—	—
030	950	Low	740	730	700	660	610	—	—	—	—	—	—	—
		Med	830	810	770	730	680	620	—	—	—	—	—	—
		High	1000	950	900	830	750	690	630	—	—	—	—	—
036	1200	Low	1290	1250	1200	1150	1080	1000	—	—	—	—	—	—
		Med	1410	1350	1290	1220	1150	1060	900	—	—	—	—	—
		High	1500	1440	1370	1290	1210	1120	1000	900	—	—	—	—
041	1250	Low	950	900	840	780	720	700	—	—	—	—	—	—
		Med	1200	1140	1080	1010	930	870	820	—	—	—	—	—
		High	1490	1400	1320	1240	1160	1080	990	910	—	—	—	—
042	1400	Low	1210	1210	1190	1160	1120	1080	—	—	—	—	—	—
		Med	1460	1450	1430	1390	1330	1250	1160	—	—	—	—	—
		High	1750	1710	1670	1620	1560	1460	1330	1210	1080	—	—	—
048 (208/230V)	1600	Low	1450	1440	1420	1400	1360	1320	—	—	—	—	—	—
		Med	1700	1670	1630	1580	1530	1470	1400	—	—	—	—	—
		High	1930	1870	1810	1740	1670	1600	1520	1430	1340	—	—	—
048 (460V)	1600	Low	1886	1853	1818	1773	1724	1654	1562	1481	1386	1299	883	—
		Med	2029	1993	1946	1897	1837	1763	1662	1564	1460	1360	1254	—
		High	2225	2170	2105	2032	1961	1885	1793	1666	1541	1435	1298	—
060	2000	Low	1560	1550	1540	1530	1505	1475	1440	1400	—	—	—	—
		Med	1890	1880	1870	1860	1825	1790	1730	1670	1590	1500	—	—
		High	2220	2200	2150	2100	2050	2000	1940	1870	1800	1700	1590	—
070	2100	Low	1570	1560	1550	1540	1530	1505	1475	1440	1400	—	—	—
		Med	1900	1890	1880	1870	1860	1825	1790	1730	1670	1590	1500	—
		High	2240	2220	2200	2150	2100	2050	2000	1940	1870	1800	1700	1590

NOTE(S):

a. 575V models employ 1 speed motor (high only).

50PCH, PCV Blower Performance — Constant Torque Motor

50PCH, PCV	RATED AIRFLOW	TAP #	AIRFLOW (cfm) AT EXTERNAL STATIC PRESSURE (in. wg)											
			0.10	0.20	0.30	0.40	0.50	0.60	0.70	0.80	0.90	1.00	1.10	1.20
015	500	1	480	440	410	370	340	—	—	—	—	—	—	—
		2	530	490	450	420	380	340	—	—	—	—	—	—
		3	600	560	510	470	440	410	370	—	—	—	—	—
		4	650	600	560	520	500	480	440	380	—	—	—	—
		5	710	660	620	580	550	520	490	470	—	—	—	—
018	650	1	630	590	560	530	490	—	—	—	—	—	—	—
		2	720	700	670	630	600	560	—	—	—	—	—	—
		3	790	770	750	710	670	620	560	—	—	—	—	—
		4	910	890	850	810	740	670	590	520	—	—	—	—
		5	1010	970	920	860	810	750	660	530	—	—	—	—
024	850	1	620	600	570	540	490	—	—	—	—	—	—	—
		2	730	710	670	640	610	550	—	—	—	—	—	—
		3	820	790	760	740	710	670	630	—	—	—	—	—
		4	940	910	880	850	800	740	660	—	—	—	—	—
		5	1070	1010	950	900	840	760	670	—	—	—	—	—
030	950	1	620	600	570	540	490	—	—	—	—	—	—	—
		2	730	710	670	640	610	550	—	—	—	—	—	—
		3	820	790	760	740	710	670	630	—	—	—	—	—
		4	940	910	880	850	800	740	660	—	—	—	—	—
		5	1070	1010	950	900	840	760	670	—	—	—	—	—
036	1200	1	1120	1090	1055	1030	1000	—	—	—	—	—	—	—
		2	1260	1230	1200	1170	1140	1080	—	—	—	—	—	—
		3	1330	1290	1250	1210	1170	1100	1030	—	—	—	—	—
		4	1400	1360	1310	1250	1190	1120	1040	960	—	—	—	—
		5	1470	1420	1360	1290	1220	1140	1050	970	890	—	—	—
041	1250	1	840	770	700	620	—	—	—	—	—	—	—	—
		2	1220	1150	1080	1010	950	—	—	—	—	—	—	—
		3	1430	1360	1280	1200	1130	1080	—	—	—	—	—	—
		4	1540	1460	1380	1300	1220	1140	1060	—	—	—	—	—
		5	1620	1550	1470	1370	1260	1180	1090	1000	—	—	—	—
042	1400	1	1270	1250	1230	1210	—	—	—	—	—	—	—	—
		2	1440	1420	1410	1410	1400	1380	1340	—	—	—	—	—
		3	1540	1530	1510	1500	1490	1470	1430	1350	—	—	—	—
		4	1650	1630	1610	1600	1580	1530	1460	1360	1240	—	—	—
		5	1730	1720	1700	1670	1620	1570	1490	1380	1260	1100	—	—
048	1600	1	1390	1370	1350	1320	—	—	—	—	—	—	—	—
		2	1600	1580	1550	1530	1510	—	—	—	—	—	—	—
		3	1730	1700	1670	1650	1630	1600	1580	1540	—	—	—	—
		4	1830	1810	1780	1760	1740	1710	1670	1600	1520	—	—	—
		5	1930	1910	1880	1860	1830	1780	1720	1640	1540	1420	—	—
060	2000	1	1900	1880	1860	1820	—	—	—	—	—	—	—	—
		2	2000	1970	1950	1920	1890	1860	—	—	—	—	—	—
		3	2110	2090	2060	2030	2010	1970	1940	1910	1880	—	—	—
		4	2220	2200	2170	2140	2110	2080	2050	2060	2050	2000	1920	—
		5	2340	2320	2290	2260	2230	2210	2180	2150	2110	2070	2000	1930
070	2100	1	2050	2010	1970	1930	—	—	—	—	—	—	—	—
		2	2150	2120	2080	2030	1990	1960	—	—	—	—	—	—
		3	2270	2230	2200	2160	2120	2080	2040	2010	1980	—	—	—
		4	2390	2350	2320	2280	2250	2200	2160	2130	2100	2070	2030	—
		5	2520	2480	2450	2420	2380	2330	2290	2260	2220	2170	2100	2020

50PCH, PCV Blower Performance — Constant Airflow Motor^{a,b}

50PCH, PCV	FAN SPEED	DEFAULT FACTORY SETTINGS	AIRFLOW (cfm) AT EXTERNAL STATIC PRESSURE (in. wg)											
			0.10	0.20	0.30	0.40	0.50	0.60	0.70	0.80	0.90	1.00	1.10	1.20
015	A - Low	X	450	450	450	450	450	450	450	440	440	430	—	—
	A - Normal		500	500	500	500	500	500	500	480	470	460	—	—
	A - Hi		580	580	580	580	580	580	580	570	560	550	—	—
018	B - Low	X	550	540	540	540	540	540	540	530	520	500	—	—
	B - Normal		650	650	650	650	650	650	640	630	610	590	—	—
	B - Hi		750	750	750	750	750	750	740	730	710	690	—	—
024	C - Low	X	720	720	720	720	720	720	720	700	650	560	—	—
	C - Normal		850	850	850	850	850	850	850	850	800	700	—	—
	C - Hi		960	960	960	960	960	960	960	960	880	790	—	—
030	D - Low	X	810	810	810	810	810	810	810	770	720	650	—	—
	D - Normal		950	950	950	950	950	950	950	900	850	780	—	—
	D - Hi		980	980	980	980	980	980	980	950	900	820	—	—
036	A - Low	X	1020	1020	1020	1020	1020	1020	1000	990	960	930	—	—
	A - Normal		1200	1200	1200	1200	1200	1200	1180	1160	1130	1090	—	—
	A - Hi		1380	1380	1380	1380	1380	1380	1360	1330	1300	1250	—	—
041	A - Low	X	1100	1100	1100	1100	1100	1090	1070	1050	1020	990	—	—
	A - Normal		1280	1280	1280	1280	1280	1260	1240	1220	1180	1140	—	—
	A - Hi		1300	1300	1300	1300	1300	1280	1260	1240	1200	1160	—	—
042	B - Low	X	1190	1190	1190	1190	1190	1190	1190	1190	1190	1190	1190	—
	B - Normal		1400	1400	1400	1400	1400	1400	1400	1400	1400	1400	1400	—
	B - Hi		1630	1630	1630	1630	1630	1630	1630	1630	1630	1630	1630	—
048	A - Low	X	1340	1340	1340	1340	1340	1340	1340	1340	1340	1340	1340	—
	A - Normal		1600	1600	1600	1600	1600	1600	1600	1600	1600	1600	1600	—
	A - Hi		1810	1810	1810	1810	1810	1810	1810	1810	1810	1810	1810	—
060	A - Low	X	1700	1700	1700	1700	1700	1700	1700	1700	1700	1690	1690	1680
	A - Normal		2000	2000	2000	2000	2000	2000	2000	2000	2000	1980	1980	1980
	A - Hi		2220	2220	2220	2220	2220	2220	2220	2220	2220	2130	2100	2070
070	B - Low	X	1870	1870	1870	1870	1870	1870	1870	1870	1870	1870	1870	1870
	B - Normal		2200	2200	2200	2200	2200	2200	2200	2200	2200	2200	2200	2200
	B - Hi		2330	2330	2330	2330	2330	2330	2330	2330	2330	2330	2330	2330

NOTE(S):

- a. Air flow is 70% of tabulated values during fan only operation.
- b. Air flow is 85% of tabulated value during passive dehumidification mode when enabled.

50PC Electrical Data with PSC Blower Motor

50PC UNIT	RATED VOLTAGE V-Ph-Hz	VOLTAGE MIN/MAX	COMPRESSOR			BLOWER MOTOR			MIN CIRCUIT AMP	MAX FUSE/HACR
			QTY	RLA	LRA	FLA	HP	FLA		
50PC007	208-230/1/60	197/253	1	2.5	17.7	0.96	0.10	3.5	4.1	15
	265/1/60	238/292	1	2.1	13.5	0.85	0.10	3.0	3.5	15
50PC009	208-230/1/60	197/253	1	3.4	22.2	0.96	0.10	4.4	5.2	15
	265/1/60	238/292	1	2.9	18.8	0.85	0.10	3.8	4.5	15
50PC012	115/1/60	103/126	1	9.6	58.4	2.20	0.10	11.8	14.2	20
	208-230/1/60	197/253	1	4.6	27.9	0.96	0.10	5.6	6.7	15
	265/1/60	238/292	1	3.8	22.2	0.85	0.10	4.7	5.6	15
50PC015	208-230/1/60	197/253	1	5.6	29.0	1.10	0.17	6.7	8.1	15
	265/1/60	238/292	1	4.6	20.0	0.90	0.17	5.5	6.7	15
50PC018	208-230/1/60	197/253	1	7.4	33.0	1.80	0.25	9.2	11.1	15
	265/1/60	238/292	1	6.0	28.0	1.60	0.25	7.6	9.1	15
50PC024	208-230/1/60	197/253	1	13.5	58.3	1.80	0.25	15.3	18.7	30
	265/1/60	238/292	1	9.0	54.0	1.60	0.25	10.6	12.9	20
	208-230/3/60	197/253	1	7.1	55.4	1.80	0.25	8.9	10.7	15
	460/3/60	414/506	1	3.5	28.0	0.90	0.25	4.4	5.3	15
50PC030	208-230/1/60	197/253	1	12.8	64.0	1.80	0.25	14.6	17.8	30
	265/1/60	238/292	1	10.9	60.0	1.60	0.25	12.5	15.2	25
	460/3/60	414/506	1	5.1	28.0	0.90	0.25	6.0	7.3	15
50PC036	208-230/1/60	197/253	1	15.2	79.0	4.40	0.50	19.6	23.4	35
	208-230/1/60 ^a	197/253	1	15.4	83.9	4.40	0.50	19.8	23.7	35
	265/1/60	238/292	1	11.6	72.0	3.30	0.50	14.9	17.8	25
	208-230/3/60	197/253	1	10.4	73.0	4.40	0.50	14.8	17.4	25
	460/3/60	414/506	1	5.8	38.0	1.80	0.50	7.6	9.1	15
50PC041	208-230/1/60	197/253	1	15.4	83.9	4.40	0.75	19.8	23.7	35
	208-230/3/60	197/253	1	10.4	73.0	4.40	0.75	14.8	17.4	25
	460/3/60	414/506	1	5.8	38.0	2.80	0.75	8.6	10.1	15
50PC042	208-230/1/60	197/253	1	16.2	109.0	4.40	0.50	20.6	24.7	40
	208-230/3/60	197/253	1	11.2	84.0	4.40	0.50	15.6	18.4	25
	460/3/60	414/506	1	5.6	44.0	1.80	0.50	7.4	8.8	15
50PC048	208-230/1/60	197/253	1	19.6	130.0	4.40	0.75	24.0	28.9	45
	208-230/3/60	197/253	1	13.7	83.1	4.40	0.75	18.1	21.5	35
	460/3/60	414/506	1	6.2	41.0	2.80	0.75	9.0	10.6	15
	575/3/60	517/633	1	4.8	33.0	2.60	0.75	7.4	8.6	15
50PC060	208-230/1/60	197/253	1	26.3	134.0	5.50	0.75	31.8	38.4	60
	208-230/1/60 ^b	197/253	1	24.7	166.0	5.50	0.75	30.2	36.4	60
	208-230/3/60	197/253	1	15.6	110.0	5.50	0.75	21.1	25.0	40
	460/3/60	414/506	1	7.8	52.0	2.80	0.75	10.6	12.6	20
	575/3/60	517/633	1	5.8	38.9	2.60	0.75	8.4	9.9	15
50PC070	208-230/1/60	197/253	1	28.3	178.0	5.50	0.75	33.8	40.9	60
	208-230/3/60	197/253	1	19.2	136.0	5.50	0.75	24.7	29.5	45
	460/3/60	414/506	1	8.7	66.1	2.80	0.75	11.5	13.7	20
	575/3/60	517/633	1	6.9	55.3	2.60	0.75	9.5	11.2	15

NOTE(S):

- a. For units produced after week 46 of 2019.
- b. For units produced after week 48 of 2019.

LEGEND

- FLA — Full Load Amps
- HACR — Heating, Air-Conditioning and Refrigeration
- LRA — Locked Rotor Amps
- RLA — Rated Load Amps



50PC Electrical Data with Constant Torque ECM Blower Motor

50PC UNIT	VOLTAGE CODE	RATED VOLTAGE V-Ph-Hz	VOLTAGE MIN/MAX	COMPRESSOR			BLOWER MOTOR			MIN CIRCUIT AMP	MAX FUSE/HACR
				QTY	RLA	LRA	FLA	HP	FLA		
50PC015	1	208-230/1/60	197/253	1	5.6	29.0	2.8	0.33	8.4	9.8	15
	2	265/1/60	238/292	1	4.6	20.0	2.6	0.33	7.2	8.4	15
50PC018	1	208-230/1/60	197/253	1	7.4	33.0	2.8	0.33	10.2	12.1	15
	2	265/1/60	238/292	1	6.0	28.0	2.6	0.33	8.6	10.1	15
50PC024	1	208-230/1/60	197/253	1	13.5	58.3	2.8	0.33	16.3	19.7	30
	2	265/1/60	238/292	1	9.0	54.0	2.6	0.33	11.6	13.9	20
	3	208-230/3/60	197/253	1	7.1	55.4	2.8	0.33	9.9	11.7	15
	4	460/3/60	414/506	1	3.5	28.0	2.1	0.50	5.6	6.5	15
50PC030	1	208-230/1/60	197/253	1	12.8	64.0	2.8	0.33	15.6	18.8	30
	2	265/1/60	238/292	1	10.9	60.0	2.6	0.33	13.5	16.2	25
	3	208-230/3/60	197/253	1	8.3	58.0	2.8	0.33	11.1	13.2	20
	4	460/3/60	414/506	1	5.1	28.0	2.1	0.50	7.2	8.5	15
50PC036	1	208-230/1/60	197/253	1	16.7	79.0	4.1	0.50	20.8	25.0	40
	1	208-230/1/60 ^a	197/253	1	15.4	83.9	4.1	0.50	19.5	23.4	35
	2	265/1/60	238/292	1	11.6	72.0	3.6	0.50	15.2	18.1	25
	3	208-230/3/60	197/253	1	10.4	73.0	4.1	0.50	14.5	17.1	25
	4	460/3/60	414/506	1	5.8	38.0	2.1	0.50	7.9	9.4	15
50PC041	1	208-230/1/60	197/253	1	15.4	83.9	6.0	0.75	21.4	25.3	40
	3	208-230/3/60	197/253	1	10.4	73.0	6.0	0.75	16.4	19.0	25
	4	460/3/60	414/506	1	5.8	38.0	3.2	0.75	9.0	10.5	15
50PC042	1	208-230/1/60	197/253	1	16.7	109.0	6.0	0.75	22.7	26.9	40
	3	208-230/3/60	197/253	1	11.2	84.0	6.0	0.75	17.2	20.0	30
	4	460/3/60	414/506	1	5.6	44.0	3.2	0.75	8.8	10.2	15
50PC048	1	208-230/1/60	197/253	1	19.6	130.0	6.0	0.75	25.6	30.5	50
	3	208-230/3/60	197/253	1	13.7	83.1	6.0	0.75	19.7	23.1	35
	4	460/3/60	414/506	1	6.2	41.0	3.2	0.75	9.4	11.0	15
50PC060	1	208-230/1/60	197/253	1	26.3	134.0	7.6	1.00	33.9	40.5	60
	1	208-230/1/60 ^b	197/253	1	24.7	166.0	7.6	1.00	32.3	38.5	60
	3	208-230/3/60	197/253	1	15.6	110.0	7.6	1.00	23.2	27.1	40
	4	460/3/60	414/506	1	7.8	52.0	4.0	1.00	11.8	13.8	20
50PC070	1	208-230/1/60	197/253	1	28.3	178.0	7.6	1.00	35.9	43.0	70
	3	208-230/3/60	197/253	1	19.2	136.0	7.6	1.00	26.8	31.6	50
	4	460/3/60	414/506	1	8.7	66.0	4.0	1.00	12.7	14.9	20

NOTE(S):

- a. For units produced after week 46 of 2019.
- b. For units produced after week 48 of 2019.

LEGEND

- FLA — Full Load Amps
- HACR — Heating, Air-Conditioning and Refrigeration
- LRA — Locked Rotor Amps
- RLA — Rated Load Amps



50PC Electrical Data with Constant Airflow ECM Blower Motor^a

MODEL	V/Ph/Hz	VOLTAGE MIN/MAX	COMPRESSOR			BLOWER MOTOR		TOTAL UNIT FLA	MIN CIRCUIT AMPS	MAX FUSE/ HACR
			QTY	RLA	LRA	FLA	HP			
50PC015	208-230/1/60	197/253	1	5.6	29	2.8	0.33	8.4	9.8	15
	265/1/60	238/292	1	4.6	20	2.6	0.33	7.2	8.4	15
50PC018	208-230/1/60	197/253	1	7.4	33	2.8	0.33	10.2	12.1	15
	265/1/60	238/292	1	6.0	28	2.6	0.33	8.6	10.1	15
50PC024	208-230/1/60	197/253	1	13.5	58.3	2.8	0.33	16.3	19.7	30
	265/1/60	238/292	1	9.0	54	2.6	0.33	11.6	13.9	20
	208-230/3/60	197/253	1	7.1	55.4	2.8	0.33	9.9	11.7	15
	460/3/60	414/506	1	3.5	28	2.6	0.33	6.1	7.0	15
50PC030	208-230/1/60	197/253	1	12.8	64	2.8	0.33	15.6	18.8	30
	265/1/60	238/292	1	10.9	60	2.6	0.33	13.5	16.2	25
	208-230/3/60	197/253	1	8.3	58	2.8	0.33	11.1	13.2	20
	460/3/60	414/506	1	5.1	28	2.6	0.33	7.7	9.0	15
50PC036	208-230/1/60	197/253	1	15.4	83.9	4.3	0.50	19.7	23.6	35
	265/1/60	238/292	1	11.6	72	4.1	0.50	15.7	18.6	30
	208-230/3/60	197/253	1	10.4	73	4.3	0.50	14.7	17.3	25
	460/3/60	414/506	1	5.8	38	4.1	0.50	9.9	11.4	15
50PC041	208-230/1/60	197/253	1	15.4	83.9	6.8	0.75	22.2	26.1	40
	208-230/3/60	197/253	1	10.4	73	6.8	0.75	17.2	19.8	30
	460/3/60	414/506	1	5.8	38	5.5	0.75	11.3	12.8	15
50PC042	208-230/1/60	197/253	1	16.7	109	6.8	0.75	23.5	27.7	40
	208-230/3/60	197/253	1	11.2	84	6.8	0.75	18.0	20.8	30
	460/3/60	414/506	1	5.6	44	5.5	0.75	11.1	12.5	15
50PC048	208-230/1/60	197/253	1	19.6	130	6.8	0.75	26.4	31.3	50
	208-230/3/60	197/253	1	13.7	83.1	6.8	0.75	20.5	23.9	35
	460/3/60	414/506	1	6.2	41	5.5	0.75	11.7	13.3	15
50PC060	208-230/1/60	197/253	1	24.7	166	9.1	1.00	33.8	40.0	60
	208-230/3/60	197/253	1	15.6	110	9.1	1.00	24.7	28.6	40
	460/3/60	414/506	1	7.8	52	6.9	1.00	14.7	16.7	20
50PC070	208-230/1/60	197/253	1	28.3	178	9.1	1.00	37.4	44.5	70
	208-230/3/60	197/253	1	19.2	136	9.1	1.00	28.3	33.1	50
	460/3/60	414/506	1	8.7	66	6.9	1.00	15.6	17.8	25

NOTE(S):

a. 460V units with Constant Airflow ECM blower motors require a neutral wire (4 wires).

LEGEND

FLA — Full Load Amps
HACR — Heating, Air-Conditioning and Refrigeration
LRA — Locked Rotor Amps
RLA — Rated Load Amps



Aquazone™ water source heat pumps are available in a flexible, efficient array of models, which can be used in all types of water loop, ground water, and ground loop type systems. Aquazone products provide optimal energy efficient solutions and adapt to the most challenging design requirements.

Water loop system

Water loop (or boiler/tower) system applications typically include a number of units plumbed to a common piping system. For optimal performance, this system should be designed between 2.25 and 3 gpm per ton of cooling capacity. The system is comprised of highly efficient packaged reverse cycle heat pump units interconnected by a water loop. The water circuit serves as both a sink and source for heat absorption and rejection and is designed for entering water temperatures between 50 and 90°F. Within this temperature range units can heat or cool as required from the same water source. Transferring heat from warm to cold spaces in the building, whenever they coexist, conserves energy rather than creating new heat.

Refer to the **Carrier Water Source Heat Pump System Design Guide** for assistance designing water loop systems. The guide includes a practical approach for the most current design recommendations including:

- Product application including horizontal, vertical, console, rooftop and water-to-water applications.
- Ventilation methods and system design including energy recovery.
- Acoustical considerations for different product types.
- Addressing indoor air quality (IAQ) issues such as condensate removal, humidity control.
- Air distribution design including diffuser selection/layout and ductwork design.
- Hydronic system design including pipe sizing/layout and boiler/tower sizing.
- Control configurations such as stand alone, DDC, DCV (demand controlled ventilation), and VVT® (variable volume and temperature) controls.
- Water Source Heat Pump Efficiency/Operational Cost Comparison chart.
- System variations such as a system without a boiler, variable pumping, and VAV (variable air volume) for interior use.

Ground water systems

To utilize Aquazone units in ground water applications, extended range should be specified. This will provide factory-installed insulation on the coaxial coil to prevent condensate from dripping when entering water temperatures are below 50°F. In addition, the copper coaxial coil installed on the Aquazone units may not be suitable for all water conditions. Refer to the Water Conditioning section for proper coaxial coil material selection.

Surface water system

This system is typically located near a lake or pond. In this application, the loop can be submerged in a series of coils beneath the water surface. The number of coils required depends on system load and design. This application requires minimum piping and excavation.

Open loop system

This system is used where ground water is plentiful. In this application, ground water is pumped through supply piping from the well to the building. The water is then pumped back into the ground through a discharge well as it leaves the building. An additional heat exchanger is usually installed between the building water piping system and the ground water piping system. This design limits the amount of piping and excavation required.

Aquazone units are available with an extended range option for open or closed loop systems. To conserve water on this type of system, a slow opening/closing solenoid valve is recommended. Depending on loop water temperatures, a water regulating valve may be needed.

Ground loop systems

There are many commonly specified designs for ground loop applications. Typical designs include vertical and horizontal loops. In some applications, water is piped from the ground or lake directly to the water source heat pump. Piping is limited to the amount of pipe required to get the water from the source to the unit.

NOTE: When utilizing Aquazone water source heat pumps in ground loop systems, refer to design considerations in the ground water system section.

Horizontal ground loop

This system is used when adequate space is available and trenching can be easily accomplished. A series of parallel pipes are laid out in trenches 3 to 6 ft below the ground surface, and then back-filled. Often, multiple pipes are used to maximize the heat transfer capability of each trench. The amount of pipe and the size of the ground loop field are based on ground conditions, heating, and cooling requirements of the application and system design.

Vertical ground loop

This system is used in vertical borehole applications. This design is well suited for retrofit applications when space is limited or where landscaping is already complete and minimum disruption of the site is desired. The vertical ground loop system contains a single loop of pipe inserted into a hole. The hole is back-filled and grouted after the pipe is inserted. The completed loop is concealed below ground. The number of loops required depends on ground conditions, heating and cooling requirements, and the depth of each hole.

Hybrid systems

In some applications, it may be beneficial to incorporate a cooling tower into the ground loop system to reduce the overall cost. A hybrid system discards excess heat into the air and increases the cooling performance of the ground loop.

Condensate drainage

Venting

Properly vent condensate lines to prevent fan pressure from causing water to hang up in the piping. Condensate lines should be pitched to assure full drainage of condensate under all load conditions. Use chemical treatment to remove algae in the condensate pans and drains in geographical areas that are conducive to algae growth.

Trapping

Condensate trapping is a necessity on every water source heat pump unit. A trap is provided to prevent the backflow of moisture from the condensate pan and into the fan intake or downstream into the mechanical system. The water seal or the length of the trap depends on the positive or negative pressure on the drain pan. As a rule of thumb, size the water seal 1 in. for every 1 in. of negative pressure on the unit. The water seal is the distance from the bottom of the unit condensate piping connection to the bottom of the condensate drain line run-out piping. Therefore, the trap size should be double the water seal dimension.

Horizontal units

Horizontal units should be sloped toward the drain at a 1/4 in. per foot pitch. If it is not possible to meet the pitch requirement, a condensate pump should be designed and installed at the unit to pump condensate to a building drain. Horizontal units are not internally trapped; therefore an external trap is necessary. Each unit must be installed with its own individual trap and means to flush or blow out the condensate drain. It is not acceptable to use a common trap or vent for multiple units. The condensate piping system should not be designed with a pipe size smaller than the drain connection pipe size.

Vertical units

All vertical units require installation of an external trap.

Water conditioning

In some applications, maintaining proper water quality may require higher corrosion protection for the water-to-refrigerant heat exchanger. Water quality varies from location to location and is unique for each job. Water characteristics such as pH value, alkalinity, hardness, and specific conductance are important when considering any WSHP application. Water typically includes impurities and hardness that must be removed. The required treatment will depend on the water quality as well as type of system. Water problems fall into three main categories:

1. Scale formation caused by hard water reduces the heat transfer rate and increases the water pressure drop through the heat exchanger. As water is heated, minerals and salts are precipitated from a solution and deposited on the inside surface of the pipe or tube.
2. Corrosion is caused by absorption of gases from the air coupled with water on exposed metal. Corrosion is also common in salt-water areas.
3. Organic growths such as algae can reduce the heat transfer rate by forming an insulating coating on the inside tube surface. Algae can also promote corrosion by pitting.

NOTE: In most commercial water loop applications, Aqua-zone WSHP units use copper water-to-refrigerant heat exchanger. Units can and should be equipped with a cupronickel heat exchanger for applications where water is outside the standard contaminant limits for a copper heat exchanger.

Acoustical design

Sound power levels represent the sound as it is produced by the source, the WSHP unit, with no regard to attenuation between the source and the space. Acoustical design goals are necessary to provide criteria for occupied

spaces where people can be comfortable and communicate effectively over the background noise of the air-conditioning system and other background noise sources.

Acoustical design goals are desirable sound pressure levels within a given conditioned space and are represented by noise criteria (NC) curves. The NC curve levels represent a peak over a full spectrum of frequencies. A high value in a low frequency band has the same effect on NC level as a lower value in a high frequency band. It is important that sound levels be balanced over the entire spectrum relative to the NC curve. The lower the NC criteria curve, the more stringent the room acoustical design must be to meet the design goals.

It is important to know how to convert NC levels from the unit ratings in terms of sound power (L_w). This conversion depends on the specifics of the acoustical environment of the installation.

The resulting calculations are compared to the NC curve selected for the area to assess the acoustical design.

Some of the factors that affect conversion of sound power to sound pressure and consequent NC level include:

- type of acoustical ceiling
- use of metal or flex duct
- absorption in the occupied space
- location in the occupied space
- open or closed layout plan
- use of open or ducted returns
- orientation of unit to occupant
- use of lined or unlined duct

Hot gas reheat

Hot gas reheat (HGRH) allows a WSHP to dehumidify the space when the space temperature is satisfied but the space humidity is high. High humidity can promote mold and bacteria growth, poor indoor air quality (IAQ), and cause occupant discomfort.

Possible causes of excess humidity could be a byproduct of the unit having to operate under a widely varying load, an oversized unit that is short cycling, a high percentage of unconditioned outside air being introduced into the space, a high latent load in the space or any location where humidity infiltration is a problem.

A properly sized WSHP unit operating in cooling mode will dehumidify the air as it cools. Once the space temperature is satisfied and cooling mode is disabled, the unit no longer dehumidifies. Operating the unit in cooling mode for the sole purpose of dehumidifying will cause the space to become cold and uncomfortable. HGRH allows the unit to continue dehumidifying the space without over cooling the space.

Dehumidification with HGRH requires a control system with dehumidification capabilities, such as a thermostat with dehumidification output, a thermostat with separate humidistat, or a DDC controller with humidity sensor and dehumidification output.

Once the space temperature is satisfied but the space humidity is above the desired set point, the control system sends a dehumidification command (H input) to the WSHP. The WSHP is now in dehumidification mode.

In dehumidification mode, the fan, reversing valve, HGRH valve, and compressor are all enabled. The reversing valve

directs cold refrigerant liquid to the indoor air coil and the HGRH valve directs warm refrigerant vapor to the HGRH coil.

As the fan draws warm, humid air into the unit, the air passes through the indoor air coil where it is cooled and dehumidified, due to the cold liquid refrigerant flowing in the coil. The cooled and dehumidified air then passes through the HGRH coil where it is reheated to a neutral temperature (68°F to 78°F typical), due to the warm refrigerant vapor flowing in the coil. The air exits the unit at a neutral temperature and low humidity (dry).

The unit will remain in dehumidification mode until the space humidity is reduced below the set point or there is a call for space cooling, which is prioritized over dehumidification mode.

The moisture removal capacity of a WSHP in a specific application will depend on multiple factors including the WSHP sizing, the nominal latent capacity, the application airflow, the application temperatures and humidity, and the application fluid flow and fluid temperature.

WSHP Builder can be utilized to simulate the performance of WSHP units with HGRH under the desired application conditions and will specify the unit leaving air dry bulb temperature

and wet bulb temperature, which can be used to determine the leaving air relative and absolute humidity levels.

The target leaving air dry bulb temperature for unit with HGRH in dehumidification mode is between 68°F and 78°F. The target leaving air wet bulb temperature should result in a relative humidity is between 40 and 60%, based on the dry bulb temperature. If the relative humidity is too high, reduce the fan speed or increase the unit size until the desired conditions are met.

Alternate methods of dehumidification with WSHPs include fan speed control and condenser water reheat. Fan speed control is one of the simplest and most efficient methods of dehumidification, but only provides dehumidification when the unit is in cooling mode. Condenser water reheat can be an effective method of dehumidification in boiler/tower applications, but is not very efficient. Condenser water reheat requires hot loop temperatures (which reduces cooling efficiency) to achieve a neutral discharge air temperature and requires an extra pump which adds to the unit power consumption. Condenser water reheat coils often have a higher airside pressure drop than HGRH coils, which results in higher fan energy consumption.

Water Quality Guidelines

CONDITION	HX MATERIAL ^a	CLOSED RECIRCULATING ^b	OPEN LOOP AND RECIRCULATING WELL ^c		
Scaling Potential — Primary Measurement Above the given limits, scaling is likely to occur. Scaling indexes should be calculated using the limits below.					
pH/Calcium Hardness Method	All	N/A	pH < 7.5 and Ca Hardness, <100 ppm		
Index Limits for Probable Scaling Situations (Operation outside these limits is not recommended.)					
Scaling indexes should be calculated at 150°F for direct use and at 90°F for indirect HX use. A monitoring plan should be implemented.					
Ryznar Stability Index	All	N/A	6.0 to 7.5 If >7.5 minimize steel pipe use.		
Langelier Saturation Index	All	N/A	-0.5 to +0.5 If <=0.5 minimize steel pipe use. Based upon 150°F direct well, 85°F indirect well HX.		
Iron Fouling					
Iron Fe ²⁺ (Ferrous) (Bacterial Iron Potential)	All	N/A	<0.2 ppm (Ferrous) If Fe ²⁺ (ferrous) >0.2 ppm with pH 6 to 8, O ₂ <5 ppm, check for iron bacteria.		
Iron Fouling	All	N/A	<0.5 ppm of Oxygen Above this level deposition will occur.		
Corrosion Prevention ^d					
pH	All	6 - 8.5 Monitor/treat as needed.	6 to 8.5 Minimize steel pipe below 7 and no open tanks with pH <8.		
Hydrogen Sulfide (H ₂ S)	All	N/A	<0.5 ppm At H ₂ S>0.2 ppm, avoid use of copper and cupronickel piping or HXs. Rotten egg smell appears at 0.5 ppm level. Copper alloy (bronze or brass) cast components are acceptable to <0.5 ppm.		
Ammonia Ion as Hydroxide, Chloride, Nitrate and Sulfate Compounds	All	N/A	<0.5 ppm		
Maximum Chloride Levels	Maximum allowable at maximum water temperature.				
			50°F (10°C)	75°F (24°C)	100°F (38°C)
	Copper	N/A	<20 ppm	NR	NR
	Cupronickel	N/A	<150 ppm	NR	NR
	304 SS	N/A	<400 ppm	<250 ppm	<150 ppm
316 SS	N/A	<1000 ppm	<550 ppm	<375 ppm	
Titanium	N/A	>1000 ppm	>550 ppm	>375 ppm	
Erosion and Clogging					
Particulate Size and Erosion	All	<10 ppm of particles and a maximum velocity of 6 fps. Filtered for maximum 800 micron size.	<10 ppm (<1 ppm "sandfree" for reinjection) of particles and a maximum velocity of 6 fps. Filtered for maximum 800 micron size. Any particulate that is not removed can potentially clog components.		
Brackish	All	N/A	Use cupronickel heat exchanger when concentrations of calcium or sodium chloride are greater than 125 ppm are present. (Seawater is approximately 25,000 ppm.)		

NOTE(S):

- Heat exchanger materials considered are copper, cupronickel, 304 SS (stainless steel), 316 SS, titanium.
- Closed recirculating system is identified by a closed pressurized piping system.
- Recirculating open wells should observe the open recirculating design considerations.
- If the concentration of these corrosives exceeds the maximum allowable level, then the potential for serious corrosion problems exists.
Sulfides in the water quickly oxidize when exposed to air, requiring that no agitation occur as the sample is taken. Unless tested immediately at the site, the sample will require stabilization with a few drops of one Molar zinc acetate solution, allowing accurate sulfide determination up to 24 hours after sampling. A low pH and high alkalinity cause system problems, even when both values are within ranges shown. The term pH refers to the acidity, basicity, or neutrality of the water supply. Below 7.0, the water is considered to be acidic. Above 7.0, water is considered to be basic. Neutral water registers a pH of 7.0.
To convert ppm to grains per gallon, divide by 17. Hardness in mg/l is equivalent to ppm.

LEGEND

- HX** — Heat Exchanger
- N/A** — Design Limits Not Applicable Considering Recirculating Potable Water
- NR** — Application Not Recommended
- SS** — Stainless Steel

The WSHP Open multi-protocol controller will control mechanical cooling, heating, hot gas reheat and waterside economizer outputs based on its own space temperature input and set points. An optional CO₂ IAQ (indoor air quality) sensor mounted in the space can maximize the occupant comfort. The WSHP Open has its own hardware clock that is automatically set when the heat pump software is downloaded to the board. Occupancy types are described in the scheduling section below. The following sections describe the functionality of the WSHP Open multi-protocol controller. All point objects that are referred to in this sequence of operation will be referenced to the objects as viewed in the BACview⁶ handheld user interface.

Scheduling

Scheduling is used to start/stop the unit based upon a time period to control the space temperature to specified occupied heating and cooling set points. The controller is defaulted to control by occupied set points all the time, until either a Time Schedule is configured with the Equipment Touch™ interface, i-Vu® Open, or a Third Party control system Enables/Disables the BAS On/Off point. Your local time and date must be set for these functions to operate properly. The occupancy source can be changed to one of the following:

Occupancy schedules

The controller will be occupied 24/7 until a Time schedule has been configured using either, i-Vu Open, Equipment Touch or a third party Enables/Disables the BAS On/Off point. This can be disabled by going to Config>Unit>Occupancy Schedules and changing the point from Enable to Disable.

NOTE: This point must be Enabled in order for i-Vu Open or BACview⁶ to assign a Time schedule to the controller.

Schedule_Schedule

The unit will operate according to the schedule configured and stored in the unit. The schedule is accessible via the Equipment Touch user interface, i-Vu Open, or Field Assistant. The daily schedule consists of a start/stop time (standard or 24 hour mode) and seven days of the week, starting with Monday and ending on Sunday.

Occupancy input contact (option)

If configured for remote occupancy control (default), the WSHP Open controller has the capability to use an external dry contact closure to determine the occupancy status of the unit. You will need to disable the Occupancy Schedules in order to utilize the Occupancy Contact Input. The control will cause the unit to go into an occupied mode whenever the abnormal input is sensed. After the input returns to its normal state, the unit will stay in the occupied mode for the configured Occupancy Override Delay period (15 minutes default).

NOTE: Scheduling can only be controlled from one source.

BAS (building automation system) on/off

For use with a Building Automation System that supports network scheduling, you will need to disable the Occupancy Schedules so the BAS system can control the unit

through a network communication and the BAS scheduling function.

NOTE: Scheduling can only be controlled from one source.

Global occupancy scheduling

The WSHP Open controller has the capability to read the occupancy status from another unit so that a group of WSHPs can be controlled from a single occupancy schedule. The local Occupancy Schedules must be disabled in order to utilize the global occupancy input.

NOTE: Scheduling can only be controlled from one source.

BACnet network occupancy input

The WSHP Open controller has the capability to accept an external BACnet Binary Network Input for occupancy control. This function is only compatible with units used in BACnet systems. You will need to configure the “System Occupancy” BACnet network input point to locate the device and point name where the external occupancy point information resides. Also Occupancy Schedules must be disabled in order to utilize this input.

NOTE: Scheduling can only be controlled from one source.

Fire/smoke detector (FSD) input (field optional)

The WSHP Open controller has the capability to read the status of a NC FSD contact input to determine if a fire or smoke detector alarm is present. If the controller determines an alarm condition is present, all heating, cooling and the fan are disabled. The normal state of the switch is factory set to Normally Closed and cannot be changed.

Shutdown input

The WSHP Open controller has a shutdown input (software) which when set to its Active mode will cause the WSHP to safely shut down in a controlled fashion. Heating and cooling will be disabled after any minimum runtime conditions expire and the fan will be disabled after the fan off timer expires. All alarms are reset but any active alarm will remain active. After the shutdown input transitions from Active mode to Inactive mode, the WSHP Open controller will restart after the configured power fail restart delay expires.

Indoor fan

The indoor fan will operate in any one of three modes depending upon the user configuration selected. Fan mode can be defined/selected as Auto, Continuous, or Always On. In Auto mode the fan is in intermittent operation during both occupied and unoccupied periods. Continuous fan is intermittent during unoccupied periods and continuous during occupied periods. Always On operates the fan continuously during both occupied and unoccupied periods. In the default mode, Continuous, the fan will be turned on whenever any one of the following is true:

- It is in occupied mode. Determined by its occupancy status.
- Whenever there is a demand for cooling or heating in the unoccupied mode.
- When there is a call for dehumidification (optional).

When power is reapplied after a power outage, there will be a configured time delay of 5 to 600 seconds before starting the fan. There are also configured fan delays for Fan On and Fan Off. The fan on delay defines the delay time (0 to 30 seconds; default 10) before the fan begins to operate after heating or cooling is started while the fan off delay defines the delay time (0 to 180 seconds; default 45) the fan will continue to operate after heating or cooling is stopped. The fan will continue to run as long as the compressors, heating stages, or the dehumidification relays are on. If the SPT failure alarm or condensate overflow alarm is active; the fan will be shutdown immediately regardless of occupancy state or demand.

Automatic 3-speed fan control

The WSHP Open controller is capable of controlling up to three fan speeds. The motor will operate at the lowest speed possible to provide quiet and efficient fan operation with the best latent capability. The motor will increase speed if additional cooling or heating is required to obtain the desired space temperature set point. The control increases the motor's speed as the space temperature rises above the cooling or below the heating set point. The amount of space temperature increase above or below the set point required to increase the fan speed is user configurable in the set point. Also, the control will increase the fan speed as the Supply Air Temperature approaches the configured minimum or maximum limits.

Fan speed control - during heating

Whenever heat is required and active, the control continuously monitors the supply air temperature to verify it does not rise above the configured Maximum Heating SAT Limit (110°F default). As the SAT approaches this value, the control will increase the fan speed as required to ensure the SAT will remain 5°F below the limit. This feature provides the most quiet and efficient operation by operating the fan at the lowest speed possible.

Fan speed control - during cooling

Whenever mechanical cooling is required and active, the control continuously monitors the supply air temperature to verify it does not fall below the configured Minimum Cooling SAT Limit (50°F default). As the SAT approaches this value, the control will increase the fan speed as required to ensure the SAT will remain 5°F above the limit. Fan will operate at lowest speed to maximize latent capacity during cooling.

Fan status (option)

An optional input can be configured as either an occupancy input contact or a fan status input. If configured as fan status, the controller will compare the status of the fan to the desired commanded state. The fan status sensor must be field provided and installed. Whenever the fan is commanded to run (ON), the fan status will be checked and verified to match the commanded state. If the fan status is not on, then a fan status alarm will be generated after 1 minute and the equipment's compressor(s) and auxiliary heat will be disabled and the optional OA damper will close (if equipped).

Cooling

The WSHP Open controller will operate one or two stages of compression to maintain the desired cooling set point. The compressor outputs are controlled by the PI (proportional-integral) cooling loop and cooling stages capacity

algorithm. They will be used to calculate the desired number of stages needed to satisfy the space by comparing the space temperature (SPT) to the appropriate cooling set point. The waterside economizer, if applicable, will be used for first stage cooling in addition to the compressor(s).

The following conditions must be true in order for the cooling algorithm to run:

- Cooling is set to Enable
- The Fire/Smoke Input and Shutdown modes are inactive
- Heat mode is not active and the compressor time guard(s) have expired
- Condensate Overflow input is Normal
- Fan Status is true (if option is enabled)
- If occupied, the SPT is greater than the occupied cooling set point
- Space temperature reading is valid
- If unoccupied, the SPT is greater than the unoccupied cooling set point.
- If economizer cooling is available and active and the economizer alone is insufficient to provide enough cooling.
- OAT is greater than the Cooling lockout temperature if OAT is available
- Condenser Water Pump is on (if condenser water linkage active)

If all the above conditions are met, the compressors will be energized as required, otherwise they will be de-energized. If cooling is active and should the SAT approach the minimum SAT limit, the fan will be indexed to the next higher speed. Should this be insufficient and if the SAT falls further (equal to the minimum SAT limit), the fan will be indexed to the maximum speed. If the SAT still continues to fall 5°F below the minimum SAT limit, all cooling stages will be disabled.

During Cooling, the reversing valve output will be held in the cooling position (either B or O type as configured) even after the compressor is stopped. The valve will not switch position until the heating mode is required.

The configuration screens contain the Min SAT parameter as well as cooling lockout based on outdoor air temperature (OAT), both can be adjusted to meet various specifications.

There is a 5-minute off time for the compressor as well as a 5-minute time delay when staging up to allow the SAT to achieve a stable temperature before energizing a second stage of capacity. Likewise, a 45-second delay is used when staging down.

After a compressor is staged off, it may be restarted again after a normal time-guard period of 5 minutes and if the supply air temperature has increased above the minimum supply air temperature limit.

The WSHP Open controller provides a status input to monitor the compressor operation. The status is monitored to determine if the compressor status matches the commanded state. This input is used to determine if a refrigerant safety switch or other safety device has tripped and caused the compressor to stop operating normally. If this should occur, an alarm will be generated to indicate the faulted compressor condition.

Reverse cycle heating

The WSHP Open controller will operate one or two stages of compression to maintain the desired heating set point.

The compressor outputs are controlled by the heating PI (proportional-integral) loop and heating stages capacity algorithm. They will be used to calculate the desired number of stages needed to satisfy the space by comparing the space temperature (SPT) to the appropriate heating set point. The following conditions must be true in order for the heating algorithm to run:

- Heating is set to Enable
- The Fire/Smoke Input and Shutdown modes are inactive
- Cool mode is not active and the compressor time guard has expired
- Condensate Overflow input is Normal
- Fan Status is true (if option is enabled)
- If occupied, the SPT is less than the occupied heating set point
- Space temperature reading is valid
- If unoccupied, the SPT is less than the unoccupied heating set point
- OAT is less than the Heating lockout temperature if OAT is available.
- Condenser Water Pump is on (if condenser water linkage active)

If all the above conditions are met, the heating outputs will be energized as required, otherwise they will be de-energized. If the heating is active and should the SAT approach the maximum SAT limit, the fan will be indexed to the next higher speed. Should this be insufficient, then if the SAT rises further and reaches the maximum heating SAT limit, the fan will be indexed to the maximum speed. If the SAT still continues to rise 5°F above the maximum limit, all heating stages will be disabled.

During Heating, the reversing valve output will be held in the heating position (either B or O type as configured) even after the compressor is stopped. The valve will not switch position until the cooling mode is required.

The configuration screens contain the Max SAT parameter as well as heating lockout based on outdoor air temperature (OAT), both can be adjusted to meet various specifications.

There is a 5-minute off time for the compressor as well as a 5-minute time delay when staging up to allow the SAT to achieve a stable temperature before energizing a second stage of capacity. Likewise, a 45-second delay is used when staging down.

After a compressor is staged off, it may be restarted again after a normal time-guard period of 5 minutes and if the supply air temperature has fallen below the maximum supply air temperature limit.

The WSHP Open controller provides a status input to monitor the compressor operation. The status is monitored to determine if the compressor status matches the commanded state. This input is used to determine if a refrigerant safety switch or other safety device has tripped and caused the compressor to stop operating normally. If this should occur, an alarm will be generated to indicate the faulted compressor condition. Also, if auxiliary heat is available (see below), the auxiliary heat will operate to replace the reverse cycle heating and maintain the space temperature as required.

Auxiliary heat

Single stage electric auxiliary heat

The control can operate a single stage of electric heat installed on the discharge side of the unit in order to maintain the desired heating set point should the compressor capacity be insufficient or a compressor failure occurs. Unless a compressor fault condition exists, the heat stage will only operate to supplement the heat provided by the compressor if the space temperature falls more than one degree below the desired heating set point. The heat stage will be controlled so the SAT will not exceed the Maximum Heating SAT limit and subject to a two-minute minimum OFF time to prevent excessive cycling. Should the compressor(s) fail to operate and heating is required, the auxiliary heat will operate as required to maintain the space temperature set point.

Indoor air quality (IAQ) and demand controlled ventilation (DCV)

If the optional indoor air quality sensor is installed or the network input point "System Space AQ" is utilized, the WSHP Open controller can maintain indoor air quality, with a field-installed modulating OA damper providing demand controlled ventilation. The control operates the modulating OA damper during occupied periods. The control monitors the CO₂ level and compares it to the configured set points and adjusts the ventilation rate as required. The control provides proportional ventilation to meet the requirements of ASHRAE specifications by providing a base ventilation rate and then increasing the rate as the CO₂ level increases. The control will begin to proportionally increase ventilation when the CO₂ level rises above the start ventilation set point and will reach the full ventilation rate when the CO₂ level is at or above the maximum set point. A user configurable minimum damper position ensures that proper base ventilation is delivered when occupants are not present. The IAQ configurations can be accessed through the configuration screen. The following conditions must be true in order for this algorithm to run:

- Damper control is configured for DCV.
- The Fire/Smoke Input and Shutdown modes are inactive.
- Fan Status is true (if option is enabled).
- The unit is in an occupied mode.
- IAQ sensor reading is greater than the DCV Start Control set point.

The control has four user adjustable set points: DCV start control set point, DCV Maximum Control set point, Minimum damper position and the DCV Maximum damper position.

NOTE: In order for the damper to maintain proper base ventilation, the fan must be configured to operate in either the Continuous or Always On mode.

Two-position OA damper

The control can be configured to operate as a ventilation damper in a 2-position ventilation mode to provide the minimum ventilation requirements during occupied periods. This control operation still utilizes the modulating damper actuator.

Dehumidification with hot gas reheat (HGRH)

The WSHP Open controller will provide occupied and unoccupied dehumidification only on units that are equipped with the factory-installed HGR option. This function requires an accessory space relative humidity sensor. When using a relative humidity sensor to control dehumidification during occupied or unoccupied times, the dehumidification set points are used accordingly. Additionally, the network input point “System Space RH” may also be used in place of the hard wired RH (relative humidity) sensor. When the indoor relative humidity becomes greater than the dehumidification set point a dehumidification demand will be acknowledged. As long as heating or cooling is not currently active, dehumidification will be energized, bringing on the supply fan (medium speed), mechanical cooling, and the integral refrigerant hot gas reheat coil. The controls will engage cooling mode, start the compressor if not already operating, and waste heat from the compressor cooling cycle will be diverted to the reheat coil. The reversing valve will be positioned to operate the compressor in the cooling mode. If a call for sensible cooling takes place during hot gas reheat operation, the hot gas reheat is de-energized and the reheat operation is turned off. Once the call for cooling has been satisfied and if there is still a need for dehumidification, the unit will continue to operate in a dehumidification mode with the compressor providing cooling and the refrigerant reheat energized.

Waterside economizer

The WSHP Open controller has the capability of providing two-position waterside economizer operation (economizer coil is mounted to the entering air side of the unit and connected to the condenser water loop) in order to be used to provide free cooling (or preheating) when water conditions are optimal. Water economizer settings can be accessed through the equipment status screen. The following conditions must be true for economizer operation:

- SAT reading is available.
- EWT reading is available.
- If occupied, the SPT is greater than the occupied cooling set point or less than the occupied heating set point and the condenser water temperature is suitable.
- Space temperature reading is valid.
- If unoccupied, the SPT is greater than the unoccupied cooling set point or less than the unoccupied heating set point and the condenser water temperature is suitable.

Two-position water economizer control

The control has the capability to control a normally open or normally closed, two-position water valve to control condenser water flow through a coil on the entering air side of the unit.

Cooling

The purpose is to provide a cooling economizer function directly from the condenser water loop when the entering water loop temperature is suitable (at least 5°F below space temperature). If the optional coil is provided and the water loop conditions are suitable, then the valve will open to provide cooling to the space when required. Should the capacity be insufficient for a period greater than 5 minutes, or should a high humidity condition occur, then the compressor will be started to satisfy the load. Should the

SAT reach the Minimum Cooling SAT limit, the economizer valve will close during compressor operation.

Heating

Additionally, the economizer control will open the water valve should the entering water loop temperature be suitable for heating (at least 5°F above space temperature) and heat is required. The valve will be controlled in a similar manner except to satisfy the heating requirement. Should the coil capacity be insufficient to satisfy the space load for more than 5 minutes, then the compressor will be started to satisfy the load. Should the SAT reach the Maximum Heating SAT limit, the economizer valve will close during compressor operation.

Demand limit

The WSHP Open controller has the ability to accept three levels of demand limit from the BACnet network. In response to a demand limit, the unit will decrease its heating set point and increase its cooling set point to widen the range in order to immediately lower the electrical demand. The amount of temperature adjustment in response is user adjustable for both heating and cooling and for each demand level. The response to a particular demand level may also be set to zero.

Power failure restart delay

The control provides a user configurable delay when recovering from a power failure or SHUTDOWN mode or when transitioning from unoccupied to occupied mode in order to prevent excessive demand when many units start simultaneously. Each unit can be user configured for a unique delay between 5 and 600 seconds. The factory programmed default delay is 180 seconds.

Fire/smoke detector alarm

The control monitors the voltage input to J1-9 to detect if a smoke detector or fire detector Normally Closed contact has opened, indicating an alarm condition. The control will verify the presence of 24 vac on this input. If the input should open at any time, an alarm will be generated after 3 seconds and the equipment (fan, compressor, auxiliary heat and damper) will immediately return to an OFF or closed state.

Space temperature alarms

The control provides the ability to generate an alarm whenever the space temperature exceeds the alarm set point. A separate occupied hysteresis and fixed unoccupied high and low alarm set points are provided. The control provides a 5-minute alarm delay during unoccupied periods. During occupied periods, the control uses the occupied temperature set points and applies the hysteresis value to determine the alarm set points. Whenever an occupancy transition from unoccupied to occupied occurs or the occupied temperature set points are changed causing an alarm condition to occur, the control will automatically calculate an alarm delay (equivalent to the configured delay time in minutes per degree F times the temperature error that occurred plus 15 minutes). This will prevent nuisance alarms whenever an occupancy change occurs and allows time for the unit to correct an alarming temperature condition.

Condenser water temperature alarm

The control has 4 configurable alarm limits for condenser water temperature. The control will verify that the water

temperature is within operating range (between high and low limits) for the specific operating mode (heating or cooling) before energizing the compressor. Once the compressor is started, the condenser water temperature is further monitored to verify that it is within limits to ensure sufficient water is flowing through the coil. Should the leaving water temperature rise above or fall below the appropriate limits, and alarm is generated and the compressor will be shut down if the condition occurs for more than 15 seconds.

Supply air temperature alarm

The control has 2 configurable alarm limits for supply air temperature. The control will verify that the supply air temperature is within operating range (between high and low limits) whenever the compressor or auxiliary heat is operating. Should the air temperature rise above or fall below the appropriate limit, an alarm is generated if the condition occurs for more than 1 minute.

High condensate/overflow alarm

The control will monitor a discrete input to determine the state of a condensate level switch. The input can be configured to alarm on either an open or closed switch condition. Should this input be in an alarm state, the control will start a timer and after the timer exceeds a configurable Condensate Overflow Alarm Delay limit (10-second default), the control will generate an alarm and the unit will disable the compressor and fan outputs.

Fan status alarm (optional)

The control generates a fan status alarm should the fan status input detect the fan is OFF after any fan speed output has been enabled. A 30-second alarm delay is used to allow the fan sufficient time to start operating before an alarm condition is detected. The control monitors the fan output and if the fan is operating at any speed, the fan status must detect the fan is operating.

Compressor status alarm

The control generates a compressor failure alarm should the compressor status input detect the compressor is OFF after the compressor output has been energized. A 6-minute alarm delay is used to allow the compressor to start (prevents alarms due to time guard operation) before an alarm condition is detected. The control monitors the compressor output and if the compressor output is energized, the compressor status input must detect the compressor operation.

Filter status alarm

The control provides the ability to generate a dirty filter alarm after the number of fan run hours exceeds a configurable filter alarm timer limit. The control monitors the fan output and if the fan is operating at any speed, it accumulates run time. Should the fan run time hours exceed the configurable limit, an alarm is generated. To reset the alarm timer after the alarm has been generated, a Reset Filter Alarm input is provided. The filter alarm can be disabled by setting the Filter Alarm Timer Delay to zero (factory default).

Indoor air quality alarm

The control provides the ability to generate a high CO₂ level alarm during occupied periods whenever the CO₂

sensor value exceeds the user adjustable limit. Whenever an occupancy transition from unoccupied to occupied occurs, or the occupied alarm limit is changed to a value that causes an alarm condition to occur, the control will automatically calculate an alarm delay:

$$\frac{\text{the configured delay time in minutes}}{\text{ppm times the error that occurred}} + 15 \text{ minutes}$$

This prevents nuisance alarms from occurring when occupancy changes or the set point is changed. The IAQ alarm can be disabled by setting Occupied High IAQ Alarm Limit to zero.

Relative humidity alarm

The control provides the ability to generate an alarm whenever the space relative humidity exceeds the alarm set point. Separate occupied and unoccupied high humidity alarm set points are provided. The control provides a 5-minute alarm delay during unoccupied periods. During occupied periods, the controller uses the occupied high RH alarm limit. Whenever an occupancy transition from unoccupied to occupied occurs, or the occupied high alarm limit is lowered causing an alarm condition to occur, the control will automatically calculate an alarm delay:

$$\frac{\text{the configured delay time in minutes}}{\% \text{ RH times the humidity error condition that occurred}} + 15 \text{ minutes}$$

This will prevent nuisance alarms whenever an occupancy change occurs and allows time for the unit to correct an alarming humidity condition.

Condenser water linkage failure alarm (if condenser water linkage was active)

The control generates a condenser water linkage failure alarm should linkage fail after once being active. The linkage status is monitored and should it fail to be updated from the Loop Controller, then a Condenser Water Linkage alarm is generated. A 6-minute alarm delay is provided to prevent false alarm from occurring.

NOTE: This alarm can only be reset by reestablishing linkage and correcting the condition that caused the linkage failure to occur or by setting the SHUTDOWN point to Active momentarily.

Airside linkage failure alarm (if airside linkage was active)

The control generates an airside linkage failure alarm should linkage fail after once being active. The linkage status is monitored and should it fail to be updated from the Master Zone Controller, then an Airside Linkage alarm is generated. A 6-minute alarm delay is provided to prevent false alarm from occurring.

NOTE: This alarm can only be reset by re-establishing linkage and correcting the condition that caused the linkage failure to occur or by setting the SHUTDOWN point to Active momentarily.

OAT sensor alarm (if network OA temperature was active)

The control generates an OAT sensor failure alarm should the value of OAT fail to be updated through the Network after once being active. The update status is monitored and should it fail to be updated, then an OAT sensor alarm is generated. An alarm delay (approximately 1 hour) is provided to prevent false alarm from occurring while minimizing the required update rate for OAT.

NOTE: This alarm can be reset by setting the SHUT-DOWN point to Active momentarily.

ZS sensor alarm (if ZS sensor was active)

The control generates a ZS sensor failure alarm should the ZS sensor fail to communicate with the control. The update status is monitored and should it fail to be updated, then the alarm is generated.

Packaged Water Source Heat Pumps

HVAC Guide Specifications (Water Loop)

Size Range: **6,100 to 64,000 Btuh**
Cooling Capacity
7,800 to 72,800 Btuh
Heating Capacity

Carrier Model Number:

50PCH, 50PCV

Part 1 — General

1.01 SYSTEM DESCRIPTION

- A. Install water source heat pumps, as indicated on the plans with capacities and characteristics as listed in the schedule and the specifications that follow. Units shall be horizontal or vertical configurations. All equipment shall be rated and certified in accordance with ANSI/AHRI/ASHRAE/ISO (American National Standard Institute/Air-Conditioning, Heating and Refrigeration Institute/American Society of Heating, Refrigerating, and Air-Conditioning Engineers/International Organization for Standardization) 13256-1. All equipment shall be tested, investigated, and determined to comply with the requirements of the standards for Heating and Cooling Equipment UL-1995 for the United States and CAN/CSA-C22.2 NO.236 for Canada, by Intertek Testing Laboratories (ETL). The units shall have AHRI/ISO and ETL-US-C labels.
- B. Units shall be supplied completely factory built and capable of operation with an entering water temperature range from 50°F to 100°F. Quality control system shall automatically perform via computer: triple leak check, pressure tests, evacuation and accurately charging of system, detailed heating and cooling mode tests, and quality cross checking all operational and test conditions to pass/fail criteria.
- C. Units shall be individually packaged on wooden skid with protective corner posts and plastic stretch wrapping for maximum protection.

1.02 QUALITY ASSURANCE

- A. All equipment listed in this section must be rated in accordance with ANSI/AHRI/ASHRAE/ISO 13256-1 performance standard, latest edition. The applicable units shall have a AHRI/ISO label. Standard cabinet panel insulation shall meet NFPA (National Fire Protection Association) 90A requirements, air erosion and mold growth limits of UL-181, stringent fungal resistance test per ASTM-C1071 and ASTM G21, and shall meet zero level bacteria growth per ASTM (American Society for Testing and Materials) G22.
- B. All units shall be factory tested in all operating modes and safety switch operation shall be verified.
- C. Serial numbers will be recorded by factory and furnished to contractor for ease of unit warranty status.

1.03 WARRANTY:

The manufacturer shall warranty the unit's parts for a period of 12 months from start-up or 18 months from shipping (whichever occurs first). The manufacturer

shall warranty the compressor (parts only) for a period of up to 5 years from shipping.

Part 2 — Product

2.01 EQUIPMENT

- A. General: Units shall be prewired and precharged in factory.
- B. Basic Construction:
 1. Units shall have the airflow arrangement as shown on the plans. If units with these arrangements are not used, the contractor supplying the water source heat pumps is responsible for any extra costs incurred by other trades and must submit detailed mechanical drawings showing ductwork requirements and changes or relocation of any other mechanical or electrical system. If other arrangements make servicing difficult, the contractor must provide access panels and clear routes to ease service. The architect must approve all changes 10 days prior to bid.
 2. All units shall have stainless steel drain pans to comply with this project's IAQ (indoor air quality) requirements. Painted steel or plastic is not acceptable.
 3. The cabinet shall be fabricated from heavy gage galvanized steel for superior corrosion protection. All interior surfaces shall be lined with 1/2 in. thick, multi-density, coated, fiberglass insulation. Insulation must be non-combustible, non-hydroscopic and anti-fungal. Insulation must meet NFPA 90A and 90B for fire protection as well as Fire Hazard classification 25/50 (per ASTM E84 and UL 723 and CAN/ULC S102-M88), ASTM C1071, erosion requirements of UL181 and be certified to meet GREENGUARD indoor air quality standards for low emitting products. Units shall have an insulated divider panel between the air-handling section and the compressor section to minimize the transmission of compressor noise, and to permit service testing without air bypass. One blower access panel and two compressor compartment access panels shall be removable with supply and return air ductwork in place.

Unit shall have a floating compressor or pan consisting of a 1/2-in. thick high density elastomeric pad between the compressor base plate and the unit base pan to prevent transmission of vibration to the structure.
 4. Units shall have a 1-in., two sided filter rack with 1-in. thick throwaway type fiberglass filter as standard. Units shall have an optional 2-in., four-sided filter rack with either 2-in. thick pleated MERV 8 filter (size 007-070) or MERV 13 filter (size 015 and larger) available. The filter rack shall incorporate a 1-in. duct flange.
 5. Cabinets shall have separate holes and knock-outs for entrance of line voltage and low voltage control wiring. Supply and return water

connections shall be brass female pipe thread fittings and mounted flush to cabinet exterior. Connections that require a backup wrench or that extrude past the unit corner post are not acceptable. Condensate connection will be stainless steel female pipe thread fittings. Plastic is not acceptable.

6. Hanging brackets shall be provided as standard for horizontal units.
7. Units shall have a short circuit current rating (SCCR) of no less than 5 kA.

C. Fan and Motor Assembly:

1. The fan shall be direct-drive centrifugal forward curved type with a dynamically balanced wheel. The housing and wheel shall be designed for quiet low velocity operation. The blower housing shall feature a removable inlet ring to facilitate removal and servicing of the fan motor. The fan motor shall be 3 speed, have 3 speed settings (208V, 230V, 265V, or 460V) or 1 speed setting (575V), permanently lubricated, PSC (permanent split capacitor) type with thermal overload protection.
2. Units rated 15,000 to 70,000 Btuh shall have an optional constant torque electronically commutated motor for premium fan efficiency. These motors shall feature 5 pre-programmed torque settings that can be changed in the field to match design requirements. 460 v-3 ph-60 Hz units with these motors must be able to operate without the need for a neutral wire for the motor.
3. Units 15,000 Btu/Hr to 70,000 Btu/Hr shall have an optional Constant Airflow ECM (Electronically Commutated Motor) for premium fan efficiency and constant air delivery over a wide range of external static pressures. These motors shall be field adjustable for $\pm 15\%$ of nominal design airflow. These motors shall provide feedback to the unit control box to verify motor operating mode and delivered CFM.
4. Blower shall have inlet rings to allow removal of wheel and motor from one side without removing housing.
5. Units supplied without permanently lubricated motors must provide external oilers for easy service.
6. The fan and motor assembly must be capable of overcoming the external static pressures as shown on the schedule.
7. The airflow/static pressure rating of the unit shall be based on a wet coil and a clean filter in place.

D. Refrigerant Components:

1. Units shall use R-410A refrigerant. All units shall have a factory sealed and fully charged refrigerant circuit.

2. Hermetic Compressor:

Hermetic rotary or scroll compressors shall be specifically designed for R-410A refrigerant and shall be internally sprung, externally isolated and with thermal overload protection.

3. Refrigerant metering thermostatic expansion valves or capillary tubes.
4. The finned tube heat exchanger shall be constructed of lanced aluminum fins not exceeding sixteen fins per inch bonded to rifled copper tubes in a staggered pattern and will have a 600 psig working refrigerant pressure. The heat exchanger shall have aluminum end sheets.

The finned tube heat exchanger shall have an optional protective coil coating. This corrosion protection shall consist of tin plated copper tubing with coated aluminum fins that must pass 1,000 hours of ASTM B117 salt fog testing. Painted, dipped or e-coated heat exchangers are not acceptable.

5. Reversing Valve:

Reversing valves shall be four-way solenoid activated refrigerant valves that will fail in the heating operation should the solenoid fail to function. Reversing valves that fail to the cooling operation shall not be allowed.

6. Coaxial (tube in tube) refrigerant-to-water heat exchanger. Refrigerant-to-water heat exchangers shall be of copper inner water tube and steel outer refrigerant tube design rated to withstand 600 psig working refrigerant pressure and 400 psig working water pressure. Shell and tube style refrigerant to water heat exchangers shall be treated as pressure vessels and shall require refrigerant pressure relief valves piped to the exterior of the building. The contractor supplying the water source heat pumps with shell and tube heat exchangers shall be responsible for any additional installation costs. Brazed plate water-to-refrigerant heat exchangers shall require additional centrifugal separators added to the supply water piping at each unit. Each separator shall have an automated clean out valve piped to a waste line. The contractor supplying water source heat pumps with brazed plate heat exchangers shall be responsible for any additional costs.
7. Safety controls shall include both a high pressure and low pressure switch. Temperature sensors shall not replace these safety switches.
8. Access fittings shall be factory installed on high and low pressure refrigerant lines to facilitate field service.
9. Activation of any safety device shall prevent compressor operation via a lockout circuit. The lockout circuit shall be reset at the thermostat or at the contractor supplied disconnect switch.

Units which may be reset at the disconnect switch only shall not be acceptable.

E. Controls and Safeties:

1. Electrical:

- a. Controls and safety devices will be factory wired and mounted within the unit. Controls shall include fan relay, compressor contactor, 24-v transformer, reversing valve coil, and Unit Protection Module (UPM). The standard transformer shall be rated for a minimum 50 va. All units shall be name plated for use with time-delay fuses or HACR circuit breakers. Unit controls shall be 24-v and provide heating or cooling as required by the remote thermostat/sensor.
- b. Optional transformers shall be rated 75va and shall have a push button reset circuit breaker on the secondary power.

2. Piping:

- a. Supply and return water connections shall be copper FPT fittings and shall be securely mounted flush to the cabinet corner post allowing for connection to a flexible hose without the use of a backup wrench.
- b. All water connections and electrical knockouts must be in the compressor compartment corner post to not interfere with the serviceability of unit. Contractor shall be responsible for any extra costs involved in the installation of units that do not have this feature.

3. Better B and Complete C Control Packages:

a. Unit Protection Module (UPM):

All units shall have a Unit Protection Module (UPM) safety control circuit with the following features:

- 1) Anti-short cycle time delay (5-minute delay on break).
- 2) Random start time delay on initial power.
- 3) Brownout/surge/power interruption protection.
- 4) 120 second low pressure switch bypass timer.
- 5) High refrigerant pressure shutdown.
- 6) Low refrigerant pressure shutdown.
- 7) Low water temperature shutdown (adjustable for closed loop systems).
- 8) Air coil freeze protection shutdown.
- 9) High condensate level shutdown.
- 10) 24 vac alarm output for remote fault indication.

- b. The UPM shall automatically reset after a safety shutdown. Restart the unit if the cause of the shutdown no longer exists (except for low temperature and high condensate level shutdowns). Should a fault re-occur within

60 minutes after reset, then a "hard" lockout will occur. A light-emitting diode (LED) shall annunciate the following alarms: brownout, high refrigerant pressure, low refrigerant pressure, low water temperature and a high level of condensate in the drain pan. The LED will display each fault condition as soon as the fault occurs. If a hard lockout occurs, then the fault LED will display the type of fault until the unit is reset.

c. The UPM shall feature the following field configurable adjustments:

- 1) Lock out reset on thermostat interruption or power reset.
- 2) Two or four restart attempts before a hard lockout.
- 3) Test mode (reduces all time delays to 5 seconds for diagnostic work).
- 4) Antifreeze setting for low water temperature sensor.

d. Safety devices include:

- 1) Low pressure cutout set a 40 psig for loss of charge protection (freezestat and/or high discharge gas temperature sensor is not acceptable).
- 2) High pressure cutout control set at 600 psig.
- 3) Low supply water temperature sensor that detects drops in refrigerant temperature that could result in water coax heat exchanger freezing.
- 4) Low air coil temperature sensor that detects drops in refrigerant temperature that could result in air heat exchanger freezing.
- 5) High level condensate sensor that shuts off the compressor if the condensate drain pan fills with water.
- 6) On board voltage detection that disables the compressor control circuit if there are extreme variations in supply voltage.

e. All units shall have a factory installed and labeled terminal strip input for field powered thermostat or DDC control.

f. Complete C packages will come with a 50 va transformer for units without HGRH or waterside economizer, and a 75 va transformer for units with HGRH or waterside economizer.

g. Better B packages will come standard with a 75 va transformer, and are not available on units built with HGRH or the waterside economizer option.

h. Units shall include a factory provided wiring diagram on the inside of the control access panel.

4. Deluxe D Controls:

Optional Deluxe D control package shall have all the features of the Complete C control package with the following additional features:

- a. 75 VA transformer.
- b. Pump-valve relay to enable a pump/valve operation when calling for compressor operation.
- c. Energy management switch to enable remote operation of WSHP (water source heat pump).
- d. Phase monitor to protect the compressor from operating in reverse rotation on three phase units (460V/3Ph only).
- e. Boilerless control shall activate an electric heater (external unit) and disable compressor should water temperature drop below set point. The relay (when energized) deactivates the compressor control circuit.

5. WSHP Open Multiple Protocol Control:

a. Units shall have all the features above (UPM) and the state of the art WSHP Open multiple protocol interface board will have the ability to be viewed in the Equipment Touch™, System Touch™, or field assistant user interface. All point objects will have the ability to be viewed in the Equipment Touch user interface. The following points must be available at a central or remote computer location:

- 1) Space temperature
- 2) Leaving water temperature
- 3) Discharge air temperature
- 4) Command of space temperature set point
- 5) Cooling status
- 6) Heating status
- 7) Low temperature sensor alarm
- 8) High pressure switch alarm
- 9) Fan on/off position of space thermostat
- 10) Unoccupied/occupied command
- 11) Cooling demand
- 12) Heating demand
- 13) Fan "ON/AUTO" command
- 14) Fault prevention with auto reset
- 15) Itemized fault code viewed with Equipment Touch interface

b. Additional WSHP Open multiple protocol control features shall include:

- 1) Three-speed fan control. Controller shall automatically, based upon space temperature input, operate the fan at the lowest of 3 selectable speeds to achieve space temperature set point.
- 2) Two-position OA (outdoor air) damper

- 3) Modulating OA damper with DCV (demand controlled ventilation)
- 4) Hot gas reheat solenoid valve
- 5) Two-position water economizer control
- 6) Modulating water economizer control
- 7) Single stage electric auxiliary heat
- 8) Power fail restart delay

6. Multiple-protocol WSHP Open controller remote ZS sensors for DDC (direct digital controls) control options. Only Carrier ZS sensors can be used with the WSHP Open controller. Sensors are available as follows, and all sensors below offer monitoring of space temperature only, or space temperature and CO₂, or space temperature and humidity, or space temperature and CO₂ and humidity.

- a. ZS Standard sensor with a communication port.
- b. ZS Plus sensor with communication port, occupancy status indicator, local occupancy override and set point adjustment.
- c. ZS Pro sensor with communication port, occupancy status indicator, local occupancy override, set point adjustment, LCD (liquid crystal diode) display, alarm indicator and fan speed control.
- d. ZS Pro-F sensor with communication port, occupancy status indicator, local occupancy override, set point adjustment, LCD display, alarm indicator, fan speed control, cooling/heating/fan only mode control and F to C conversion.

F. Factory-Installed Options:

1. Cupronickel coaxial water-to-refrigerant heat exchangers shall be provided, with cupronickel inner water tube construction.
2. Evaporator coil protection shall be factory installed with tin electro-plated copper tubing and high-tech polymer coated aluminum fins to protect the air coil from all forms of corrosive elements in the airstream.
3. Sound attenuation (mute) package shall consist of high technology compressor blanket on sizes 018 and above.
4. Extended range option shall consist of insulation on the piping inside the unit leading to and from the coaxial coil along with insulation on the coaxial coil itself. This insulation will allow for operation with entering water temperatures from 25 to 110°F.
5. Units shall have an optional 2-way electrically operated shut-off valve mounted internally in the unit cabinet. The two-way motorized solenoid valve is rated for a 300 psig working pressure.
6. Units shall have an optional water flow regulating valve set to 3 gallons per minute of water flow per nominal ton of refrigeration capacity.

7. Hot Gas Reheat (HGRH): Units with a capacity above 12,000 Btuh shall be equipped with optional hot gas bypass. On/Off HGRH shall be controlled by a thermostat with dehumidification output, humidistat, or DDC control connected to the unit H terminal and shall start the unit in the reheat mode should the humidity be above the set point once the space temperature is satisfied. Cooling or heating requirements shall take precedent over HGRH.
8. Hot Gas Bypass: Units shall be supplied with an ETL listed modulating hot gas bypass valve with factory supplied and installed controls to prevent air coils from frost development by taking hot gas and bypassing the water coil and expansion device and reintroducing the hot gas into the refrigeration line prior to the air coil. The hot gas bypass valve shall maintain a minimum refrigerant suction pressure to allow for a light load cooling module or a low entering air temperature cooling mode.
9. Waterside Economizer: Waterside economizer shall be completely installed at the factory, with an additional condensate drain pan, motorized 3-way valve, Aquastat, and all internal electric controls. Waterside economizer shall be rated at 400 psig and UL (Underwriters Laboratories) listed for applications with the heat pump. This option is externally mounted outside the unit.
10. Unit mounted disconnect: A non-fused factory mounted disconnect shall be installed on the unit.
11. Closed cell foam (CCF) shall be installed on interior surfaces of water source heat pump and shall meet the density and compression requirements of ASTM D 1056, the water absorption requirements of ASTM D-1667 and the tensile and elongation requirements of ASTM D-412. Closed cell foam shall meet the flammability requirements of FMVSS302, UL94 and ASTM E84.

G. Accessories:

1. Carrier commercial thermostat controls are available as follows:
Edge® Pro 7-day programmable thermostat offers 2-stage heat, 2-stage cool, remote contact input, remote sensor capability, pre-occupancy purge, soft start, manual/auto changeover, 4 settings per day, 24 vac, backlit LCD, keypad lockout, no batteries required, 5-minute compressor protection, never lost memory, 3 security levels, and temperature display in degrees F or C.
2. Hose Kits and Valves:
All units shall be connected to main water supply and return headers with hoses. The hoses shall be

2 feet long, braided stainless steel rated to 400 psig at 265°F. Hoses may contain optional ball valves with P/T ports, Y strainers with blow down valves and/or auto flow regulators as specified in the schedule.

3. Electric Duct Heaters:

- a. Duct heater shall be slip-in type and shall be UL approved for zero clearance to combustible surfaces. The heater shall bear a UL/CSA label. Control panel and element housing shall be constructed of heavy gage galvanized steel. All heating elements shall be made of nickel/chromium resistance wire with ends terminated by means of staking and heliarc welding to machine screws. Heating element support structure shall consist of galvanized steel wire formed and constructed to support ceramic bushings through which the heating element passes. Control cabinet shall be constructed of heavy gage galvanized steel with multiple knockouts for field wiring. Control cabinet shall have a solid cover also of heavy gage galvanized steel and held in place with hinges and tool-release latches.
- b. Duct heater shall be supplied with primary over temperature protection by built in disc type automatic reset thermal cutouts and secondary over temperature protection by built in disc type manually resettable thermal cutouts. These devices must function independently of one another and are not acceptable if series connected in the control circuit wiring. A disconnecting magnetic control circuit is required. All duct heaters will require either a fan interlock circuit or an airflow switch.
- c. Over-current protection by means of factory-installed fusing within the control cabinet shall be provided for heaters rated at more than 48 amps. Heating elements shall be subdivided and fused accordingly.
- d. All wiring, component sizing, component spacing and protective devices within the control cabinet shall be factory installed and comply with UL standards. All heaters shall function properly with a 60 Hz power supply.
- e. A wiring diagram depicting layout and connections of electrical components within the control cabinet shall be affixed to the inside of the control cabinet cover.
- f. A rating plate label shall be affixed to the exterior of the control cabinet cover which states model number, serial number, volts, amps, phase, frequency, control volts, volt-amps and minimum airflow requirements.

