



TECHNICAL GUIDE

R-410A XP Series 6.5 TON to 12.5 ton 60 Hertz



6.5 ton to 10 ton



12.5 ton

Description

ASHRAE 90.1 Compliant

YORK® Sun™ Pro units are convertible single packages with a common footprint cabinet and common roof curb for all 6.5 ton to 12.5 ton models. All units have two compressors with independent refrigeration circuits to provide two stages of cooling. The units were designed for light commercial applications and can be easily installed on a roof curb, slab, or frame.

All Sun™ Pro units are self-contained and assembled on rigid full perimeter base rails allowing for three-way forklift access and overhead rigging. Every unit is completely charged, wired, piped, and tested at the factory to provide a quick and easy field installation.

Sun™ Pro units in all tonnage sizes are convertible between side airflow and down airflow, with a corresponding economizer if you require an economizer option.

Sun™ Pro XP units are available in the following configurations: heat pump and heat pump with electric heat. Electric heaters are available as factory-installed options or field-installed accessories.

Patents: <https://jciapat.com>

Tested in accordance with:

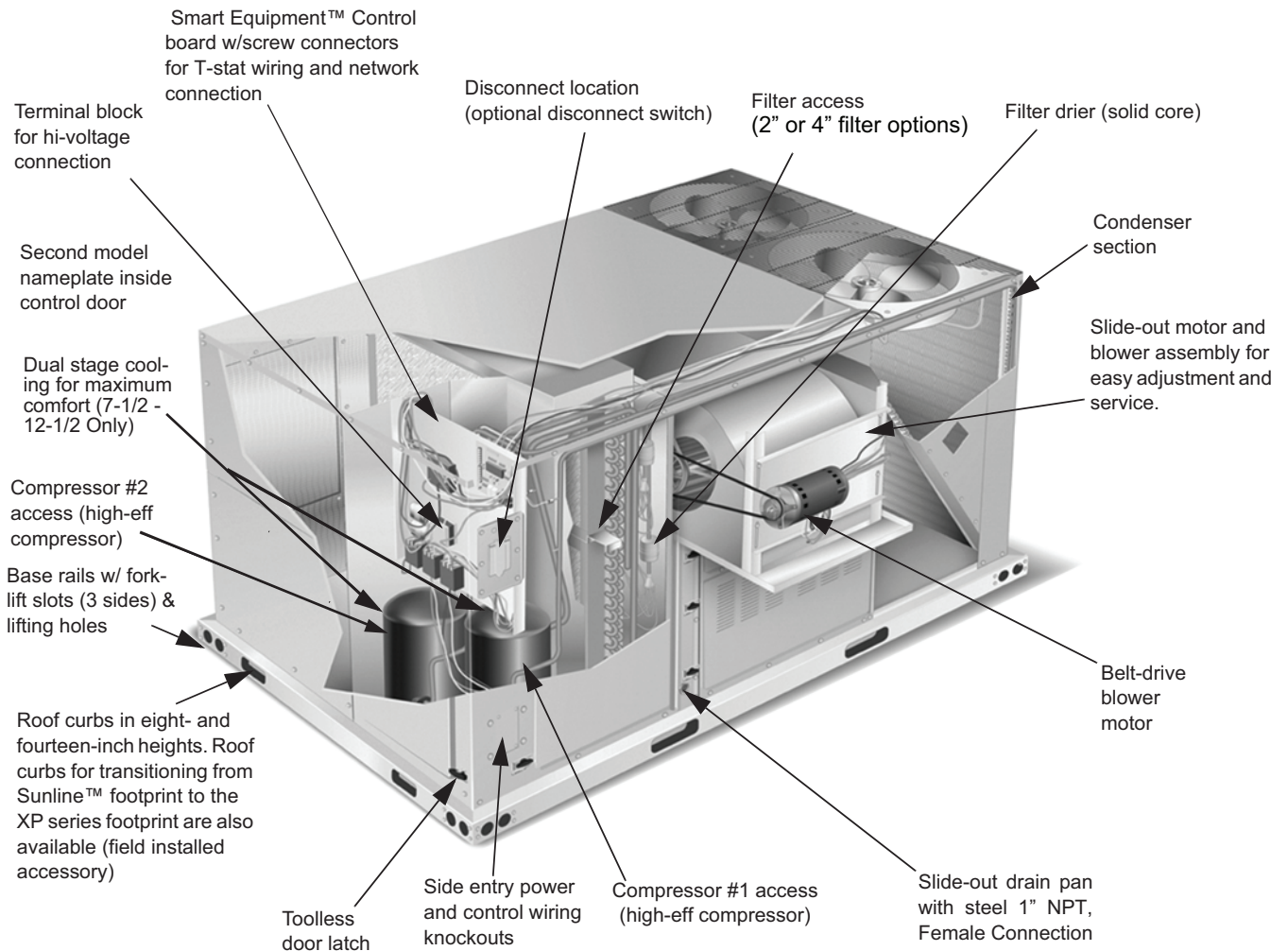

Table of contents

Description	1
Table of contents	2
Component location	2
Nomenclature	3
Features and benefits	4
Guide specifications	9
Physical data	12
Capacity performance	14
Airflow performance	26
Sound performance	33
Electrical data	35
Typical wiring diagrams	43
Weights and dimensions	51
Economizer options	59

Component location

Heat pump



Nomenclature

6.5-12.5 Ton Model Number Nomenclature

X P 090 C 00 A 2 A 1 A A A 1 A 1

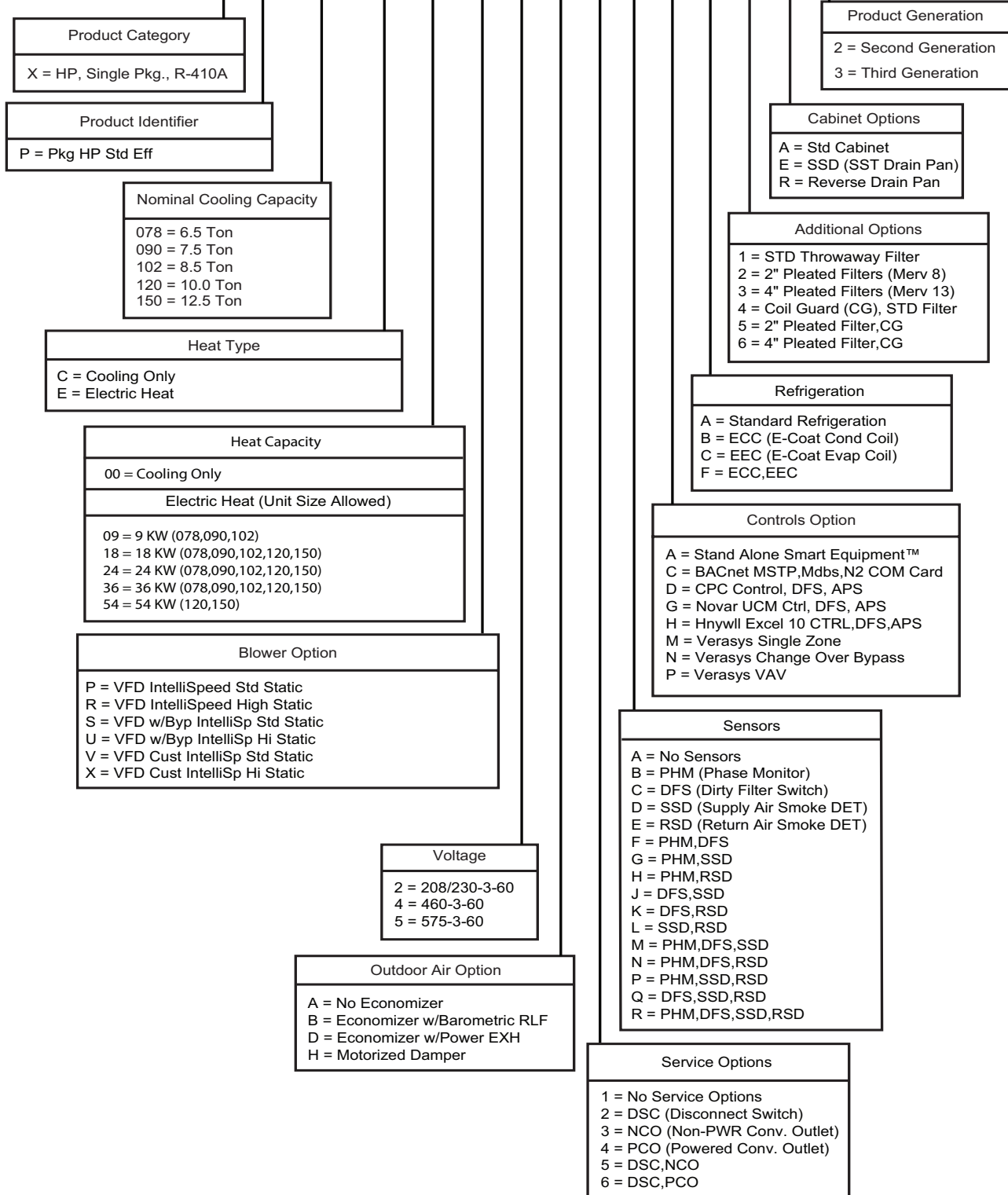

Features and benefits

Standard features

- **Service friendly:** The Sun™ Pro incorporates a number of key features for ease of serviceability. Service time is reduced through the use of hinged, toolless panels. The panels allow access to frequently inspected components and areas, including the control box, compressors, filters, indoor motor and blower, and the heating section. The panels are screwed in place at the factory to prevent access by children or other unauthorized persons. Secure the panels with screws once service is complete. Service windows have been placed in both condenser section walls. Rotate the cover to easily access the condenser coils for cleaning or inspection. The Smart Equipment™ control board provides alarm messages to help quickly identify any faults. All units use the same standard filter size. This standardization removes any confusion relating to which filter sizes are needed when changing the filter. The non-corrosive drain pan slides out of the unit for easy cleaning. The drain pan is accessed by removing the drain pan cover plate on the rear of the unit. With the plate removed, the drain pan slides out through the rear of the unit. The composite drain pan can also be ordered reversed from the factory with the connection at the rear of the unit. All Pro units have a second model nameplate located inside the control access door. This is to prevent deterioration of the nameplate through weathering.
- **Environmentally aware:** For improved indoor air quality, a combination of aluminum foil faced and elastomeric rubber insulations are used exclusively throughout the units.
- **Convertible airflow design:** The side duct openings are covered when they leave the factory. If a side supply/return is desired, the installer removes the two side duct covers from the outside of the unit and installs them over the down shot openings. No panel cutting is required. The convertible airflow design allows maximum field flexibility and minimum inventory.
- **System protection:** Suction line freezestats are supplied on all units to protect against the loss of charge and coil frosting when the economizer operates at low outdoor air temperatures while the compressors are running. Every unit has solid-core liquid line filter-driers and high and low-pressure switches. Phase monitors are available on units with scroll compressors. This accessory monitors the incoming power to the unit and protects the unit from phase loss and reversed phase rotation.
- **Advanced controls:** Smart Equipment™ control boards have standardized a number of features previously available only as options or by utilizing additional controls.

⚠ CAUTION

The Smart Equipment™ control board used in this product will effectively operate the cooling system down to 0°F when this product is applied in a comfort cooling application for people. An economizer is typically included in this type of application. When applying this product for process cooling applications (computer rooms, switchgear, etc.), please call the applications department for Ducted Systems @ 1-877-874-SERV for guidance. Additional accessories may be needed for stable operation at temperatures below 30°F.

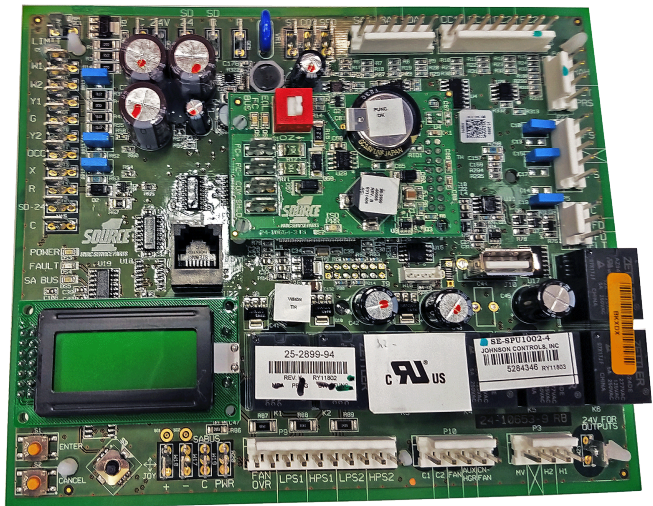

- **Units will come with the new state of the art Smart Equipment™ control system:** The new unit control incorporates the best of the already proven controls and creates a more robust, intelligent control. The goal of this control is to utilize cutting edge technology making the equipment easier to install, operate, and service. All units are factory commissioned, configured, and run tested.
- **Versatile:** The Smart Equipment™ control can be configured for use with a standard easy to connect screw terminal thermostat, A zone sensor, or can be setup to communicate with multiple BAS communication protocols to integrate with building automation systems.
- **Reduce field-installed complexity:** Each unit will come equipped with factory-installed supply air, return air, and outdoor air temperature sensors providing key temperature readings that reduce field-installed complexity.
- **On-board USB port:** The new control comes with a long list of features including data logging current and previous system faults, software update capabilities using the on board USB port, and common flash drive. The energy use monitoring capabilities allow custom tailoring, ensuring the system works more efficiently at all times and occupancy levels. Self test and start-up reports are also available from the board through the USB port.

- **Embedded LCD display:** The board has a easy to read, built-in LCD display and easy to use navigation joystick and buttons allowing the user to quickly navigate the menus displaying unit status, options, current function, supply, return and outdoor temperatures, fault codes and other information.
- **Safety monitoring:** The control monitors the outdoor, supply, and return air temperatures, and the high and low pressure switch status on the independent refrigerant circuits. On gas and electric heating units, heating the gas valve and high temperature limit switches are monitored. The control also monitors the voltage supplied to the unit and will protect the unit from low voltage due to a brown out, or other electrical issue occurs.
- **Low ambient:** An integrated low-ambient control allows units to operate in the cooling mode down to 0°F outdoor ambient without additional components or intervention. Optionally, the control board can be programmed to lockout the compressors when the outdoor air temperature is low or when free cooling is available.
- **Anti-short cycle protection:** To aid compressor life, an anti-short cycle delay is incorporated into the standard control. Compressor reliability is further ensured by programmable minimum run times. For testing, the anti-short cycle delay can be temporarily overridden with the push of a button.
- **Fan delays:** Fan on and fan off delays are fully programmable. Furthermore, the heating and cooling fan delay times are independent of one another. All units are programmed with default values based upon their configuration of cooling or heating capacity.
- **Nuisance trip protection and three strikes:** To prevent nuisance calls, the control board uses a three times, you're out philosophy. The high, low-pressure switch, anti-freeze protection, low voltage or heating high limit must trip three times within two hours before the unit control board will lock out the associated compressor. An alarm message will be displayed on the LCD screen.
- **Lead-lag:** An integrated lead-lag option allows equal run time hours on all compressors, thereby extending the life of all compressors. This option is selectable on the unit control board.
- **Low limit control (LLC):** To prevent the supply air from dropping below a specified set point, when there is a demand for cooling during cold outside conditions. (programmable Set point)
- **Reliable:** From the beginning, all units undergo computer automated testing before they leave the factory. Units are tested for refrigerant charge and pressure, unit amperage, and 100% functionality. For the long term, all units are painted with a long lasting, powder paint that stands up over the life of the unit. The paint used has been proven by a 750-hour salt spray test.
- **Full perimeter base rails:** The permanently attached base rails provide a solid foundation for the entire unit and protect the unit during shipment. The rails offer rigging holes so that an overhead crane can be used to place the units on a roof.
- **Easy installation:** Gas and electric utility knockouts are supplied in the unit underside as well as the side of the unit. Utility connections can be made quickly and with a minimum amount of field labor. All units are shipped with 2 in. throw-away filters installed.
- **Wide range of indoor airflows:** All supply air blowers are equipped with a belt drive that can be adjusted to meet the exact requirements of the job. A high static drive option is available for applications with a higher CFM or static pressure requirement.
- **Warranty:** All models include a 1-year limited warranty on the complete unit. Compressors and electric heater elements each carry a 5-year warranty. Aluminized steel has a 10-year warranty and stainless steel tubular heat exchangers carry a 15-year warranty.

Factory-installed options

There are several factory-installed options for the Pro line.

- **Optional factory-installed economizers:** Pro units offer a variety of optional factory-installed economizers with low leak dampers. The outdoor air dry bulb sensor enables economizer operation if the outdoor air temperature is less than the set point of the economizer logic module. See economizer options section to determine the correct economizer for your application.
 - **Down flow / end return economizers with barometric relief and fresh air hood:** All units offer a variety of optional factory-installed down flow economizers that are shipped, installed and wired with low leak dampers designed to meet ASHRAE 90.1, AMCA 511 Class 1A damper, and the International Energy Conservation Code (IECC) certification requirements by achieving leakage rates of 3 CFM/sq. ft. at in. of static pressure. Each economizer goes through a rigorous 60,000 cycle test. Dry bulb, single enthalpy, and dual enthalpy with a field-installed kit can be selected. The economizer has spring return, fully modulating damper actuators and is capable of introducing up to 100% outdoor air. As the outdoor air intake dampers open, the return air dampers close. The changeover from mechanical refrigeration to economizer operation is regulated by the outdoor air dry bulb temperature or the outdoor air enthalpy input. The optional field-installed single or dual enthalpy kits provide additional inputs to monitor outdoor air or return air humidity and temperature for true enthalpy control. The installer only needs to assemble the outdoor air hood, attach the enthalpy control the hood and mount the hood to the unit. The hood and the control are provided.
 - **Power exhaust:** This factory option allows down flow or horizontal end return economizer operation.
- Note:** The power exhaust must be removed from the unit and mounted in the horizontal end return duct work when applying the product in the horizontal, end return configuration.
- **Motorized outdoor air damper:** The motorized outdoor air damper includes a slide-in/plug-in damper assembly with an outdoor air hood and filters. The outdoor air dampers open to the preset position when the indoor fan

motor is energized. The damper has a range of 0% to 100% outdoor air entry.

- **Alternate indoor blower motor:** For applications with high static restrictions, units are offered with optional indoor motors that provide higher static output or higher airflow, depending upon the installer's needs.
- **Stainless steel drain pan:** An optional rust-proof stainless steel drain pan is available to provide years of trouble-free operation in corrosive environments.
- **Electric heaters:** The electric heaters range from 9kW to 54kW and are available in all the voltage options of the base units. All heaters are dual staged. All heaters are intended for single point power supply.
- **IntelliSpeed™ supply fan control option (ASHRAE 90.1 compliant):** Units configured with the *Intellispeed™* Supply Fan option will contain a VFD for multi-speed supply fan operation. This option allows the supply fan rpm to vary based on the number of compressors or heating stages energized. The economizer's minimum position will also be configurable to vary based on the supply fan VFD frequency output.
- **Disconnect switch:** For heat pump units with electric heat, a HACR breaker sized to the unit is provided. For heat pump units, a switch sized to the largest electric heat available for the particular unit is provided. Factory-installed option only.
- **Convenience outlet, non-powered or powered:** This option locates a 120V single-phase GFCI outlet with cover, on the corner of the unit housing adjacent to the compressors. The non-powered option requires the installer to provide the 120V single-phase power source and wiring. The powered option is powered by a stepdown transformer in the unit. Factory-installed option only.
- **Smoke detectors:** The smoke detectors stop operation of the unit and provide a fault message to the control board. Smoke detectors are available for both the supply or return air configurations.

▲ WARNING

Factory-installed smoke detectors in the return air, may be subjected to freezing temperatures during "off" times due to outside air infiltration. These smoke detectors have an operational limit of 32 °F to 131°F. Smoke detectors installed in areas that could be outside those limitations will have to be moved to prevent having false alarms.

- **Filters:** 2 in. Pleated MERV 8 or 4 in. Pleated MERV 13 are available to meet LEED requirements. A 2 in. Throwaway is shipped as standard.
- **Phase monitors:** Designed to prevent unit damage. The phase monitor will shut the unit down in an out-of phase condition.
- **Coil guard:** Customers can purchase a coil guard kit to protect the condenser coil from damage. Additionally, this kit stops animals and foreign objects from entering the

space between the inner condenser coil and the main cabinet. This is not a hail guard kit.

- **Dirty filter switch:** This kit includes a differential pressure switch that energizes the fault light on the unit thermostat, indicating that there is an abnormally high pressure drop across the filters. Factory-installed option or field-installed accessory.
- **E-Coat condenser coils:** The condenser coils are coated with an epoxy polymer coating to protect against corrosion.
- **E-Coat evaporator coils:** The evaporator coils are coated with an epoxy polymer coating to protect against corrosion.

Control options

- **Smart Equipment™ with communication option control:** The Smart Equipment™ with communication option control is factory-installed. It includes all the features of the Smart Equipment™ control with an additional gateway to BACnet MS/TP programmable to Modbus or N2 protocols.
- **Fault Detection and Diagnostics (FDD) refrigerant side:** A factory-installed control system option on the commercial equipment that constantly monitors refrigerant circuit pressures, refrigerant circuit temperatures, as well as the environmental temperatures and humidity via multiple sensor inputs.
 - Provides a building owner, technician or contractor with the operational characteristics of the RTUs entire refrigerant circuit to ensure the unit is functioning at its specified performance level.
 - Provides alarms if the unit is not functioning optimally.
 - Remotely accessible via the Mobile Access Portal (MAP) gateway as well as scrolled on the UCB LCD screen.
- **Novar BAS control:** The Novar® building automation system controller is factory-installed. Includes supply air sensor, return air sensor, dirty filter indicator switch, and air proving switch.
- **CPC BAS control:** The Computer Process Controls Model 810-3060 ARTC Advanced Rooftop building automation system controller is factory-installed. Includes supply air sensor, return air sensor, with optional dirty filter indicator switch and air proving switch.
- **Honeywell BAS control:** The Honeywell W7750C building automation system controller is factory-installed. Includes air supply sensor, return air sensor, with optional dirty filter indicator switch, and air proving switch.
- **Verasys:** provides a simple user experience with configurable self-recognizing controllers without the need for any additional tools. Verasys creates enhanced integration of HVACR equipment, zoning, and controls. Contractors are able to offer a complete bundled solution of equipment and controls to serve the light commercial market.

Field-installed accessories

There are several field-installed accessories available for the Pro line.

- **Down flow and end return economizers with fresh air hood and barometric relief:** All units offer a variety of optional factory-installed down flow economizers that are shipped, installed and wired with low leak dampers designed to meet ASHRAE 90.1, AMCA 511 Class 1A damper, and the International Energy Conservation Code (IECC) certification requirements by achieving leakage rates of 3 CFM/sq. ft. at 1 in. of static pressure. Each economizer goes through a rigorous 60,000 cycle test. Dry bulb, single enthalpy, and dual enthalpy with a field-installed kit can be selected. The economizer has spring return, fully modulating damper actuators and is capable of introducing up to 100% outdoor air. As the outdoor air intake dampers open, the return air dampers close. The changeover from mechanical refrigeration to economizer operation is regulated by the outdoor air dry bulb temperature or the outdoor air enthalpy input. The field-installed dual enthalpy kit provides a second input used to monitor the return air. The installer needs only to assemble the outdoor air hood, attach the enthalpy control the hood and mount the hood to the unit. The hood and control are provided.
- **Single or dual enthalpy control, accessories:** These kits contain the required components to convert a dry bulb economizer to a single enthalpy or dual enthalpy economizer.
- **Barometric relief damper:** Zero to 100% capacity barometric relief dampers for use with horizontal flow, or field-installed economizers.
- **Power exhaust:** This accessory installs in the unit with a down flow or horizontal end return economizer. Power exhaust plugs into the connector in the unit bulkhead.

Note: User must purchase the 1EH0408 barometric relief and hood kit when applying the product in a horizontal flow application. The power exhaust must be mounted in the horizontal end return ductwork.

- **Manual outdoor air damper:** Like the motorized outdoor air damper, each manual outdoor air damper includes a slide-in damper assembly with an outdoor air hood and filters. Customers have a choice of dampers with ranges of 0% to 100% or 0% to 35% outdoor air entry.
- **Motorized outdoor air damper:** The motorized outdoor air damper includes a slide-in/plug-in damper assembly with an outdoor air hood and filters. The outdoor air dampers open to the preset position when the indoor fan motor is energized. The damper has a range of 0% to 100% outdoor air entry. factory-installed option or field-installed accessory.

- **Smoke detectors:** The smoke detectors stop operation of the unit by interrupting power to the control board if smoke is detected within the air compartment.
- **CO₂ sensor:** Senses CO₂ levels and automatically overrides the economizer when levels rise above the preset limits.
- **Dirty filter switch:** This kit includes a differential pressure switch that energizes the fault light on the unit thermostat, indicating that there is an abnormally high pressure drop across the filters.
- **Coil guard:** Field-installed decorative wire coil guard.
- **Hail guard:** This kit includes a sloped hood which installs over the outside condenser coil and prevents damage to the coil fins from hail strikes. field-installed accessory only.
- **Electric heaters:** The electric heaters range from 9 kW to 54kW and are available in all the voltage options of the base units. All heaters are dual staged. All units include an adapter panel for easy installation of the electric heaters. Necessary hardware and connectors are included with the heaters. All heaters are intended for single point power supply.
- **Low limit / compressor lockout kit**
 - **Compressor lockout (CLO):** To prevent mechanical compressorized operation of the unit during cold outdoor conditions where there is a risk of returning liquid refrigerant back to the compressors.
- **Metal frame filter kit:** Metal frame with polyester filter medium.
- **Permanent filters:** Permanent filters are available.
- **Roof curbs:** The roof curbs have insulated decks and are shipped disassembled. The roof curbs are available in 8 in. and 14 in. heights. For applications with security concerns, burglar bars are available for the duct openings of the roof curbs.
- **Roof curb transition:** Single piece adapter (10 in. high) - Roof curbs for transitioning from Sunline™ units to Pro units. Fits 7.5 to 12.5 Sunline™ roof curbs only.
- **Burglar bars:** Mount in the supply and return openings to prevent entry into the duct work.
- **Thermostat:** The units are designed to operate with 24-volt electronic and electro-mechanical thermostats. All units, with or without an economizer, operate with two-stage heat/two-stage cool or two-stage cooling only thermostats, depending upon unit configuration.

Accessories

Part Number	Description
1RC0470	Roof curb, 8 in. height
1RC0471	Roof curb, 14 in. height
1RC0472	Roof curb, transition (7.5 ton through 12.5 ton)
1BD0408	Burglar bars, downflow
2TP04520925	Electric heat 9kW 230V
2TP04531825	Electric heat 18kW 230V
2TP04532425	Electric heat 24kW 230V
2TP04533625	Electric heat 36kW 230V
2TP04525425	Electric heat 54kW 230V
2TP04520946	Electric heat 9kW 460V
2TP04531846	Electric heat 18kW 460V
2TP04532446	Electric heat 24kW 460V
2TP04533646	Electric heat 36kW 460V
2TP04525446	Electric heat 54kW 460V
2TP04520958	Electric heat 9kW 575V
2TP04521858	Electric heat 18kW 575V
2TP04522458	Electric heat 24kW 575V
2TP04523658	Electric heat 36kW 575V
2TP04525458	Electric heat 54kW 575V
2TP04540925	Electric heat 9kW 230V, 42 in. tall cabinet
2TP04541825	Electric heat 18kW 230V, 42 in. tall cabinet
2TP04542425	Electric heat 24kW 230V, 42 in. tall cabinet
2TP04543625	Electric heat 36kW 230V, 42 in. tall cabinet
2TP04540946	Electric heat 9kW 460V, 42 in. tall cabinet
2TP04541846	Electric heat 18kW 460V, 42 in. tall cabinet
2TP04542446	Electric heat 24kW 460V, 42 in. tall cabinet
2TP04543646	Electric heat 36kW 460V, 42 in. tall cabinet
2TP04540958	Electric heat 9kW 575V, 42 in. tall cabinet
2TP04541858	Electric heat 18kW 575V, 42 in. tall cabinet
2TP04542458	Electric heat 24kW 575V, 42 in. tall cabinet
2TP04543658	Electric heat 36kW 575V, 42 in. tall cabinet
2MD04703824	Motorized damper, downflow without barometric relief
2MD04703924	Motorized damper, horizontal
2EE04717425	Economizer for downflow, end return horizontal, or bottom return vertical applications. includes fa hood, exhaust hood w/baro relief. all 42 in. cabinets
2EE04717625	Economizer for downflow, end return horizontal, or bottom return vertical applications. includes fa hood, exhaust hood w/baro relief. all 50 in. cabinets
2EE04709725	Economizer for downflow, end return horizontal, or bottom return vertical applications. includes fa hood, exhaust hood w/baro relief, bas ready. all 42 in. cabinets
2EE04709825	Economizer for downflow, end return horizontal, or bottom return vertical applications. includes fa hood, exhaust hood w/baro relief, bas ready. all 50 in. cabinets
2EE04706924	Horizontal economizer without barometric relief
2PE04704706*	Power exhaust 230V downflow or horizontal
2PE04704746*	Power exhaust 460V downflow or horizontal
2PE04704758*	Power exhaust 575V downflow or horizontal
2EC04700924	Dual enthalpy control (use with single enthalpy economizer)
2EC0401	Single enthalpy control
2EC0402	Dual enthalpy control (includes 2 sensors)
1EH0408	Barometric relief kit for power exhaust, horizontal application
1FA0413	Manual outside air damper 0-35%, downflow
1FA0414	Manual outside air damper 0-100%, downflow
2AQ04700624	CO2 detector unit mount
2AQ04700524	CO2 detector space mount
2SD04700824	Smoke detector for supply (all gen 5 units and greater with 2 in. and 4 in. filters)
2SD04700924	Smoke detector for return (all gen 5 units and greater with 2 in. and 4 in. filters)
2SD04701024	Smoke detector for supply and return (all gen 5 units and greater with 2 in. and 4 in. filters)
1CG0419	Coil guard (electric / electric and HP models), 8-1/2 ton and 10 ton
1CG0424	Coil guard (electric / electric and HP models), 12-1/2 ton
1CG0427	Coil guard (electric / electric and HP models), 6-1/2 ton and 7-1/2 ton
1HG0411	Hail guard kit
1HG0415	Hail guard kit, 42 in. tall cabinet
1FL0402	Permanent filter kit
1FL0423	Permanent filter kit, 42 in. tall cabinet
2DF0401	Dirty filter switch
1FF0414	2 in. only metal filter frame kit, 50 in. tall cabinet

Accessories (Continued)

Part Number	Description
1FF0415	2 in. only Metal Filter Frame Kit, 42 in. Tall Cabinet
S1-YK-MAP1810-0P	MAP (Mobile Access Portal) Gateway- For use with Smart Equipment™ Control.
S1-MP-PRTKIT-0P	MAP (Mobile Access Portal) Gateway Kit- Replacement MAP gateway protective case, lanyard and communication cable. Use only to replace worn or damaged components.

Guide specifications

General

Pro units are convertible single packages with a common footprint cabinet and common roof curb for all 6.5 to 12.5 ton models. All units have two compressors with independent R-410a refrigeration circuits to provide two stages of cooling. The units were designed for light commercial applications and can be easily installed on a roof curb, slab, or frame. All Pro units are self-contained and assembled on rigid full perimeter base rails allowing for three-way forklift access and overhead rigging. Every unit is completely charged with R-410A, wired, piped, and tested at the factory to provide a quick and easy field installation. All units are convertible between side and down airflow. Independent economizer designs are used on side and down discharge applications, as well as all tonnage sizes. Pro units are available in the following configurations: heat pump and heat pump with electric heat. Electric heaters are available as factory-installed options or field-installed accessories.

Description

Units are be factory-assembled, single package (heat pump), designed for outdoor installation. They have built in field-convertible duct connections for down discharge supply/return or horizontal discharge supply/return and be available with factory-installed options or field-installed accessories. The units shall be factory wired, piped and charged with R-410A refrigerant and factory tested prior to shipment. All unit wiring shall be both numbered and color coded. The cooling performance shall be rated in accordance with DOE and AHRI test procedures. Units shall be CSA certified to ANSI Z21.47 and UL 1995/CAN/CSA No. 236-M90 standards.

Unit cabinet

Unit cabinet shall be constructed of galvanized steel with exterior surfaces coated with a non-chalking, powder paint finish, certified at a 750-hour salt spray test per ASTM-B117 standards. Indoor blower sections shall be insulated with up to 1 in. thick insulation coated on the airside. Either aluminum foil faced or elastometric rubber insulation shall be used in the unit's compartments and be fastened to prevent insulation from entering the air stream. Cabinet doors shall be hinged with toolless access for easy servicing and maintenance. Full perimeter base rails shall be provided to assure reliable transit of equipment, overhead rigging, fork truck access and correct sealing on roof curb applications. Disposable 2 in. filters shall be furnished and be accessible through hinged access door. Fan performance measuring ports shall be provided on the outside of the cabinet to allow accurate air measurements of

evaporator fan performance without removing panels or creating bypass of the coils. Condensate pan shall be slide out design, constructed of a non corrosive material, internally sloped and conforming to ASHRAE 62-B9 standards. Condensate connection shall be a minimum of 3/4 in. I.D. female and be rigid mount connection.

Indoor evaporator fan assembly

Fan shall be a belt drive assembly and include an adjustable pitch motor pulley. Job site selected brake horsepower shall not exceed the motors nameplate horsepower rating plus the service factor. Units shall be designed to operate within the service factor. Fan wheel shall be double inlet type with forward curve blades, dynamically balanced to operate smoothly throughout the entire range of operation. Bearings shall be sealed and permanently lubricated for longer life and no maintenance. Entire blower assembly and motor shall be slide out design.

Outdoor condenser fan assembly

The outdoor fans shall be of the direct drive type, discharge air vertically, have aluminum blades riveted to corrosion resistant steel spider brackets and shall be dynamically balanced for smooth operation. The outdoor fan motors shall have permanently lubricated bearings internally protected against overload conditions and staged independently. A cleaning window shall be provided on two sides of the units for coil cleaning.

Refrigerant components

Compressors:

- Shall be fully hermetic type, direct drive, internally protected with internal high-pressure relief and over temperature protection. The hermetic motor shall be suction gas cooled and have a voltage range of + or – 10% of the unit nameplate voltage.
- Shall have internal spring isolation and sound muffling to minimize vibration and noise, and be externally isolated on a dedicated, independent mounting.

Coils:

- Evaporator and condenser coils shall have aluminum plate fins mechanically bonded to seamless internally enhanced copper tubes with all joints brazed. Coils shall be a furnace brazed design and contain epoxy lined shrink wrap on all aluminum to copper connections. Special Phenolic coating shall be available as a factory option.
- Evaporator and condenser coils shall be of the direct expansion, draw-through design.

Refrigerant circuit and refrigerant safety components shall include:

- Independent fixed-orifice or thermally operated expansion devices.
- Solid core filter drier/strainer to eliminate any moisture or foreign matter.
- Accessible service gage connections on both suction and discharge lines to charge, evacuate, and measure refrigerant pressure during any necessary servicing or troubleshooting, without losing charge.
- The unit shall have two independent refrigerant circuits, equally split in 50% capacity increments.

Unit Controls:

- Unit shall be complete with self-contained low-voltage control circuit protected by a resettable circuit breaker on the 24-volt transformer side.
- Unit shall incorporate a lockout circuit which provides reset capability at the space thermostat or base unit, should any of the following standard safety devices trip and shut off compressor.
 1. Loss-of-charge/Low-pressure switch.
 1. High-pressure switch.
 1. Freeze condition sensor on evaporator coil. If any of these safety devices trip, the LCD screen will display the alarm message.
- Unit shall incorporate "AUTO RESET" compressor over temperature, over current protection.
- Unit shall operate with conventional thermostat designs and have a low voltage terminal strip for easy hook-up.
- Unit control board shall have on-board diagnostics and fault message display.
- Standard controls shall include anti-short cycle and low voltage protection, and permit cooling operation down to a selectable value as low as 0°F.
- Control board shall monitor each refrigerant safety switch independently.

Electric heating section if equipped

An electric heating section, with nickel chromium elements, shall be provided in a range of 9 through 54 kW, offering two states of capacity all sizes. The heating section has a primary limit control (automatic reset) to prevent the heating element system from operating at an excessive temperature. The Heating Section assembly has a slide out of the unit for easy maintenance and service. Units with electric heating sections

are wired for a single point power supply with branch circuit fusing where required.

Unit operating characteristics

Unit shall be capable of starting and running at 125°F outdoor temperature, exceeding maximum load criteria of AHRI Standard 340/360. The compressor, with standard controls, shall be capable of operation down to 0°F outdoor temperature.

Electrical requirements - All unit power wiring shall enter unit cabinet at a single factory provided location and be capable of side or bottom entry to minimize roof penetrations and avoid unit field modifications. Separate side and bottom openings shall be provided for the control wiring.

Standard limited warranties - compressor – 5 years, electric heat element – 5 years, parts – 1 year

Factory-installed optional outdoor air (shall be made available by either/or):

- **Dry bulb automatic economizer** - Outdoor and return air dampers that are interlocked and positioned by a fully-modulating, spring-return damper actuator. The maximum leakage rate for the outdoor air intake dampers shall be designed to meet ASHRAE 90.1, AMCA 511 Class 1A damper, and the International Energy Conservation Code (IECC) certification requirements by achieving leakage rates of 3 CFM/sq. ft. at 1 in. of static pressure. Changeover from compressor to economizer operation shall be provided by an integral electronic enthalpy control that feeds input into the basic module. The outdoor intake opening shall be covered with a rain hood that matches the exterior of the unit. Water eliminator/filters shall be provided. Simultaneous economizer/compressor operation is also possible. Dampers shall fully close on power loss. Available with barometric relief and power exhaust.
- **Motorized outdoor air dampers** - Outdoor and return air dampers that are interlocked and positioned by a 2-position, spring-return damper actuator. A unit-mounted potentiometer shall be provided to adjust the outdoor and return air damper assembly to take in the design CFM of outdoor air to meet the ventilation requirements of the conditioned space during normal operation. Whenever the indoor fan motor is energized, the dampers open up to one of two pre-selected positions, regardless of the outdoor air enthalpy. Dampers return to the fully closed position when the indoor fan motor is de-energized. Dampers shall fully close on power loss.

Additional factory-installed options

- **Alternate indoor blower motor:** For applications with high restrictions, units are available with optional indoor blower motors that provide higher static output or higher airflow.
- **Convenience outlet, powered or non-powered:** Unit can be provided with an optional 120VAC GFCI outlet with cover on the corner of the unit housing the compressors.
- **Electric heat:** Electric Heaters range from 9 kW to 54 kW and are available in all the voltage options of the base unit.
- **Phase monitor:** Designed to prevent damage in out-of-phase condition.
- **Coil guard:** Designed to prevent condenser coil damage.
- **BAS controls hardware:** Include supply air sensor, return air sensor, dirty filter indicator and air proving switch.
- **Dirty filter switch:** This kit includes a differential pressure switch that energizes the fault light on the unit thermostat, indicating that there is an abnormally high-pressure drop across the filters.

- **Breaker:** An HACR breaker can be factory-installed on heat pumps or heat pumps with electric heat.
- **Disconnect switch:** A disconnect can be factory-installed on a cooling only units sized for the largest electric heat available.
- **Smoke detector:** A smoke detector can be factory mounted and wired in the supply and/or return air compartments.

Other pre-engineered accessories available

- **Roof curb:** 14 in. and 8 in. high, full perimeter knockdown curb, with hinged design for quick assembly.
- **Barometric relief damper:** unit mounted, downflow, duct mounted, horizontal, contains a rain hood, air inlet screen, exhaust damper and mounting hardware. Used to relieve internal air pressure through the unit during economizer operation.
- **Economizer:** downflow and horizontal flow.
- **Power exhaust:** unit mounted, downflow, duct mount horizontal flow
- **Dual enthalpy kit:** provides a second input to economizer to monitor return air.

Physical data

XP078-150 Physical data

Component	Models				
	XP078	XP090	XP102	XP120	XP150
Nominal tonnage	6.5	7.5	8.5	10	12.5
AHRI cooling performance					
Gross Capacity @ AHRI A point (Mbh)	86,000	95,000	105,600	115,000	150,000
AHRI net capacity (Mbh)	84,000	92,000	100,000	111,000	141,000
EER	12.0	11.2	11.1	11.0	10.6
IEER with Intellispeed	15.2	14.6	14.4	14.5	14.5
Nominal CFM	2,600	3,000	3,300	3,300	4,600
System power (kW)	7.0	8.3	9.2	10.0	13.2
Refrigerant type	R-410A	R-410A	R-410A	R-410A	R-410A
Refrigerant charge (lb-oz)					
System 1	14-6	13-0	13-12	12-14	17-2
System 2	14-0	13-2	13-13	12-12	15-8
AHRI heating performance					
47°F capacity rating (Mbh)	76.0	87.0	93.0	102.0	138.0
System power (kW) / COP	6.4 / 3.5	7.2 / 3.5	7.6 / 3.5	8.4 / 3.5	12.7 / 3.3
17°F capacity rating (Mbh)	44.0	51.0	53.0	59.0	82.0
System power (kW) / COP	5.9 / 2.25	6.4 / 2.25	6.9 / 2.25	7.8 / 2.25	11.0 / 2.15
Dimensions (in.)					
Length	89	89	89	89	119-7/16
Width	59	59	59	59	59
Height	50-3/4	50-3/4	50-3/4	50-3/4	50-3/4
Operating weight (lb)	1,080	1,090	1,137	1,135	1,403
Compressors¹					
Type	Scroll	Scroll	Scroll	Scroll	Scroll
Quantity	2	2	2	2	2
Unit capacity steps (%)	50 / 100	50 / 100	50 / 100	50 / 100	50/100
Condenser coil data					
Face area (sq. ft.)	29.0	29.0	29.0	29.0	47.5
Rows	2	2	2	2	2
Fins per inch	16	16	16	16	15
Tube diameter (in.)	3/8	3/8	3/8	3/8	3/8
Circuitry Type	Split-face	Split-face	Split-face	Split-face	Split-face
Refrigerant control	TXV	TXV	TXV	TXV	TXV
Evaporator coil data					
Face area (sq. ft.)	13.2	13.2	13.2	13.2	13.2
Rows	4	4	4	4	4
Fins per inch	15	15	15	15	15
Tube diameter	3/8	3/8	3/8	3/8	3/8
Circuitry Type	Intertwined	Intertwined	Intertwined	Intertwined	Intertwined
Refrigerant control	TXV	TXV	TXV	TXV	TXV

XP078-150 Physical data (Continued)

Component	Models									
	XP078		XP090		XP102		XP120		XP150	
Nominal tonnage	6.5		7.5		8.5		10		12.5	
Condenser fan data										
Quantity of fans	2		2		2		2		4	
Fan diameter (in.)	24		24		24		24		24	
Type	Prop		Prop		Prop		Prop		Prop	
Drive type	Direct		Direct		Direct		Direct		Direct	
Quantity of motors	2		2		2		2		4	
Motor hp each	1/3		1/3		1/3		1/3		1/3	
No. speeds	1		1		1		1		1	
RPM	850		850		850		850		850	
Nominal total cfm	6,800		6,800		6,800		6,800		14,000	
Belt drive evap fan data										
Quantity	1		1		1		1		1	
Fan size (in.)	15 x 15		15 x 15		15 x 15		15 x 15		15 x 15	
Type	Centrifugal		Centrifugal		Centrifugal		Centrifugal		Centrifugal	
Motor sheave	VL40	VL44	1VL40	1VM50	1VP50	1VP50	1VM50	1VM50	1VM50	1VP56
Blower sheave	AK84	AK71	AK69	AK69	AK89	AK74	AK84	AK74	AK74	BK77
Belt	A54	A52	A52	A54	A56	A54	A56	A54	A54	BX56
Motor HP each	1-1/2	2	1-1/2	3	2	3	2	3	3	5
RPM	1,725	1,725	1,725	1,725	1,725	17,25	1,725	1,725	1,725	1,725
Frame size	56	56	56	56	56	56	56	56	56	184T
Filters										
Quantity - size	4 - (24 x 20 x 2) ^{2,3}		4 - (24 x 20 x 2) ^{3,4}		4 - (24 x 20 x 2) ^{3,4}		4 - (24 x 20 x 2) ^{3,4}		4 - (24 x 20 x 2) ^{3,4}	
	4 - (24 x 20 x 2) ⁴		4 - (24 x 20 x 4) ⁵		4 - (24 x 20 x 4) ⁵		4 - (24 x 20 x 2) ⁵		4 - (24 x 20 x 4) ⁵	

1. XP078, XP090, XP102, XP120, XP150 have crankcase heaters standard
2. 2 In. Throwaway, Standard, MERV (Minimum Efficiency Reporting Value) 3.
3. 2 In. Pleated, Optional, MERV 8.
4. 4 In. Pleated, Optional, MERV 13.

XP078-150 unit limitations

Size (ton)	Model	Unit voltage	SCCR (kVA)	Unit limitations		
				Applied voltage		Outdoor DB temperature
				Minimum	Maximum	Maximum (°F)
078 (6.5)	XP	208/230-3-60	5	187	252	125
		460-3-60	5	432	504	125
		575-3-60	5	540	630	125
090 (7.5)	XP	208/230-3-60	5	187	252	125
		460-3-60	5	432	504	125
		575-3-60	5	540	630	125
102 (8.5)	XP	208/230-3-60	5	187	252	125
		460-3-60	5	432	504	125
		575-3-60	5	540	630	125
120 (10)	XP	208/230-3-60	5	187	252	125
		460-3-60	5	432	504	125
		575-3-60	5	540	630	125
150 (12.5)	XP	208/230-3-60	5	187	252	125
		460-3-60	5	432	504	125

Capacity performance

XP078-150 cooling capacities

XP078 (6.5 ton)

Air on evaporator coil		Temperature of air on condenser coil															
cfm	WB (°F)	Total capacity ¹ (MBh)	Total input (kW) ²	Sensible capacity (MBh)						Total capacity ¹ (MBh)	Total input (kW) ²	Sensible capacity (MBh)					
				Return dry bulb (°F)								Return dry bulb (°F)					
				90	85	80	75	70	65			90	85	80	75	70	65
				75°F						85°F							
1625	77	114.9	5.1	55.0	47.2	39.3	-	-	-	107.6	5.7	52.6	45.0	37.4	-	-	-
	72	103.6	5.0	64.3	55.7	47.0	38.4	-	-	97.1	5.7	61.6	53.2	44.8	36.4	-	-
	67	92.2	5.0	73.6	64.2	54.8	46.4	37.7	-	86.6	5.6	70.6	61.3	52.1	43.8	35.3	-
	62	81.6	4.9	81.6	73.7	62.6	54.0	45.5	37.0	76.7	5.5	76.7	70.8	59.5	51.1	42.6	34.2
1950	77	117.5	5.1	60.3	50.2	40.1	-	-	-	109.9	5.8	57.5	47.7	37.9	-	-	-
	72	106.6	5.1	70.5	60.1	49.8	39.4	-	-	99.5	5.7	67.5	57.4	47.2	37.1	-	-
	67	95.7	5.0	80.6	70.0	59.4	49.2	38.8	-	89.2	5.6	77.5	67.0	56.5	46.4	36.1	-
	62	87.0	4.9	87.0	79.3	69.1	58.7	48.5	38.2	81.6	5.5	81.6	76.0	65.8	55.6	45.3	35.1
	57	78.2	4.8	78.2	78.2	78.2	68.4	58.2	47.9	74.1	5.5	74.1	74.1	74.1	64.8	54.6	44.3
2275	77	120.0	5.1	65.6	53.3	41.0	-	-	-	112.2	5.8	62.4	50.5	38.5	-	-	-
	72	109.6	5.1	76.6	64.6	52.5	40.5	-	-	101.9	5.7	73.4	61.6	49.7	37.8	-	-
	67	99.2	5.0	87.6	75.8	64.0	52.1	39.9	-	91.7	5.6	84.5	72.7	60.9	49.0	37.0	-
	62	92.4	4.9	92.4	84.9	75.6	63.5	51.4	39.4	86.5	5.6	86.5	81.2	72.0	60.1	48.1	36.1
	57	85.5	4.9	85.5	85.5	85.5	75.0	62.9	50.9	81.3	5.6	81.3	81.3	81.3	71.2	59.2	47.1
2600	77	122.6	5.2	70.9	56.4	41.8	-	-	-	114.4	5.8	67.3	53.2	39.0	-	-	-
	72	112.6	5.1	82.8	69.0	55.2	41.5	-	-	104.4	5.7	79.4	65.8	52.1	38.5	-	-
	67	102.7	5.0	94.6	81.6	68.6	54.9	41.1	-	94.3	5.7	91.4	78.3	65.2	51.6	37.9	-
	62	97.8	5.0	97.8	90.6	82.0	68.2	54.4	40.6	91.4	5.6	91.4	86.4	78.3	64.6	50.8	37.1
	57	92.9	4.9	92.9	92.9	92.9	81.6	67.7	53.9	88.5	5.6	88.5	88.5	88.5	77.6	63.8	49.9
2925	72	115.7	5.1	88.9	73.4	58.0	42.5	-	-	106.8	5.8	85.3	70.0	54.6	39.2	-	-
	67	106.1	5.0	101.6	87.4	73.2	57.7	42.2	-	96.9	5.7	96.9	84.0	69.6	54.2	38.7	-
	62	103.2	5.0	103.2	96.2	88.5	72.9	57.3	41.8	96.3	5.7	96.3	91.7	84.6	69.1	53.5	38.0
	57	100.2	5.0	100.2	100.2	100.2	88.1	72.5	56.9	95.7	5.7	95.7	95.7	95.7	84.0	68.4	52.8
3250	72	118.7	5.1	95.1	77.9	60.7	43.5	-	-	109.2	5.8	91.3	74.2	57.1	40.0	-	-
	67	109.6	5.1	108.6	93.2	77.8	60.6	43.3	-	103.0	5.7	99.4	89.6	74.0	56.8	39.6	-
	62	108.6	5.1	108.6	101.8	95.0	77.7	60.3	43.0	101.2	5.7	101.2	96.9	90.8	73.6	56.3	39.0
	57	107.5	5.0	107.5	107.5	107.5	94.7	77.3	59.9	101.0	5.7	100.5	100.5	100.5	90.4	73.0	55.6
				95°F						105°F							
1625	77	100.4	6.4	50.1	42.8	35.5	-	-	-	92.9	7.3	45.8	39.1	32.5	-	-	-
	72	90.7	6.3	58.8	50.7	42.5	34.3	-	-	83.3	7.2	55.6	47.5	39.3	31.1	-	-
	67	81.0	6.2	67.5	58.5	49.5	41.2	32.9	-	73.8	7.1	65.4	55.8	46.1	37.9	29.7	-
	62	71.9	6.1	71.9	67.9	56.4	48.1	39.7	31.4	68.0	7.1	68.0	63.8	53.0	44.7	36.5	28.2
1950	77	102.3	6.4	54.7	45.2	35.8	-	-	-	94.2	7.3	51.4	41.9	32.4	-	-	-
	72	92.5	6.3	64.5	54.6	44.7	34.7	-	-	85.1	7.3	61.2	51.2	41.3	31.3	-	-
	67	82.6	6.2	74.4	64.0	53.6	43.5	33.5	-	76.0	7.2	71.0	60.6	50.2	40.1	30.1	-
	62	76.3	6.2	76.3	72.7	62.5	52.4	42.2	32.1	71.9	7.1	71.9	68.4	59.1	48.9	38.8	28.7
	57	69.9	6.1	69.9	69.9	69.9	61.2	50.9	40.7	67.8	7.1	67.8	67.8	67.8	57.7	47.5	37.3
2275	77	104.3	6.4	59.2	47.6	36.0	-	-	-	95.5	7.4	56.9	44.6	32.3	-	-	-
	72	94.3	6.4	70.3	58.6	46.9	35.1	-	-	86.8	7.3	66.7	55.0	43.3	31.6	-	-
	67	84.3	6.3	81.3	69.5	57.7	45.9	34.1	-	78.2	7.2	76.5	65.4	54.2	42.4	30.5	-
	62	80.6	6.2	80.6	77.5	68.5	56.6	44.7	32.8	75.7	7.2	75.7	73.0	65.2	53.2	41.2	29.2
	57	77.0	6.2	77.0	77.0	77.0	67.4	55.4	43.4	73.3	7.1	73.3	73.3	73.3	64.0	51.8	39.7
2600	77	106.2	6.5	63.7	50.0	36.3	-	-	-	96.8	7.4	62.5	47.4	32.3	-	-	-
	72	96.1	6.4	76.0	62.5	49.0	35.6	-	-	88.6	7.3	72.3	58.8	45.3	31.8	-	-
	67	86.0	6.3	86.0	75.0	61.8	48.2	34.7	-	80.4	7.3	80.4	70.2	58.3	44.6	30.9	-
	62	85.0	6.3	85.0	82.3	74.6	60.9	47.2	33.5	79.6	7.2	79.6	77.5	71.3	57.4	43.5	29.6
	57	84.1	6.3	84.1	84.1	84.1	73.6	59.8	46.0	78.8	7.2	78.8	78.8	78.8	70.2	56.1	42.0
2925	72	97.9	6.4	81.7	66.5	51.2	36.0	-	-	90.4	7.4	77.8	62.5	47.3	32.0	-	-
	67	92.0	6.3	87.6	80.5	65.9	50.6	35.2	-	82.5	7.3	82.5	75.0	62.3	46.8	31.3	-
	62	89.4	6.4	89.4	87.1	80.6	65.2	49.7	34.3	83.5	7.3	83.5	82.1	77.4	61.6	45.8	30.1
	57	91.2	6.4	91.2	91.2	91.2	79.8	64.2	48.7	84.4	7.3	84.4	84.4	84.4	76.4	60.4	44.4
3250	72	99.7	6.5	87.4	70.4	53.4	36.4	-	-	92.1	7.4	83.4	66.3	49.2	32.2	-	-
	67	95.2	6.4	89.3	86.1	70.1	52.9	35.8	-	90.3	7.4	84.7	79.8	66.4	49.0	31.7	-
	62	93.8	6.4	93.8	91.9	86.7	69.5	52.2	35.0	87.3	7.4	87.3	86.7	83.5	65.8	48.2	30.5
	57	93.0	6.4	92.3	92.3	92.3	86.0	68.7	51.3	86.6	7.4	86.6	86.6	86.6	82.7	64.7	46.8

XP078 (6.5 ton) (Continued)

Air on evaporator coil		Temperature of air on condenser coil															
cfm	WB (°F)	Total capacity ¹ (MBh)	Total input (kW) ²	Sensible capacity (MBh)						Total capacity ¹ (MBh)	Total input (kW) ²	Sensible capacity (MBh)					
				Return dry bulb (°F)								Return dry bulb (°F)					
				90	85	80	75	70	65			90	85	80	75	70	65
				115°F						125°F							
1625	77	85.4	8.3	41.5	35.5	29.4	-	-	-	77.9	9.2	37.2	31.8	26.4	-	-	-
	72	76.0	8.2	52.4	44.3	36.1	28.0	-	-	68.6	9.1	49.2	41.1	32.9	24.8	-	-
	67	66.6	8.0	63.3	53.1	42.8	34.7	26.5	-	59.4	9.0	59.4	50.3	39.4	31.4	23.3	-
	62	64.2	8.0	64.2	59.8	49.5	41.3	33.2	25.1	60.3	8.9	60.3	55.7	46.0	38.0	30.0	22.0
1950	77	86.1	8.3	48.1	38.6	29.0	-	-	-	77.9	9.2	44.8	35.2	25.7	-	-	-
	72	77.7	8.2	57.8	47.8	37.9	28.0	-	-	70.3	9.1	54.4	44.5	34.5	24.6	-	-
	67	69.3	8.1	67.5	57.1	46.8	36.7	26.7	-	62.7	9.0	62.7	53.7	43.4	33.3	23.3	-
	62	67.5	8.1	67.5	64.1	55.6	45.5	35.4	25.3	63.1	9.0	63.1	59.8	52.2	42.1	32.0	21.9
2275	57	65.7	8.0	65.7	65.7	64.5	54.3	44.1	33.9	63.6	8.9	63.6	63.6	61.0	50.9	40.7	30.5
	77	86.8	8.3	54.6	41.6	28.6	-	-	-	78.0	9.3	52.4	38.7	25.0	-	-	-
	72	79.4	8.2	63.2	51.4	39.7	28.0	-	-	72.0	9.2	59.6	47.9	36.1	24.4	-	-
	67	72.0	8.2	71.7	61.2	50.7	38.8	26.9	-	65.9	9.1	65.9	57.1	47.3	35.3	23.3	-
2600	62	70.8	8.1	70.8	68.4	61.8	49.7	37.6	25.5	65.9	9.1	65.9	63.9	58.4	46.2	34.0	21.8
	57	69.6	8.1	69.6	69.6	69.6	60.6	48.3	36.0	66.0	9.0	66.0	66.0	66.0	57.2	44.7	32.3
	77	87.4	8.3	61.2	44.7	28.2	-	-	-	78.1	9.3	59.9	42.1	24.2	-	-	-
	72	81.1	8.3	68.5	55.0	41.5	28.0	-	-	73.6	9.2	64.8	51.3	37.7	24.2	-	-
2925	67	74.8	8.2	74.8	65.3	54.7	40.9	27.1	-	69.2	9.2	69.2	60.4	51.2	37.3	23.3	-
	62	74.2	8.2	74.2	72.8	68.0	53.9	39.8	25.7	68.7	9.1	68.7	68.0	64.7	50.4	36.1	21.8
	57	73.6	8.1	73.6	73.6	73.6	66.8	52.5	38.1	68.3	9.1	68.3	68.3	68.3	63.5	48.8	34.1
	72	82.8	8.3	73.9	58.6	43.3	28.0	-	-	75.3	9.2	70.0	54.7	39.3	24.0	-	-
3250	67	77.5	8.3	77.5	69.4	58.7	43.0	27.3	-	72.4	9.2	72.4	63.8	55.1	39.2	23.3	-
	62	77.5	8.2	77.5	77.1	74.1	58.1	42.0	25.9	71.5	9.2	71.5	71.5	70.9	54.5	38.1	21.7
	57	77.5	8.2	77.5	77.5	77.5	73.1	56.6	40.1	70.7	9.1	70.7	70.7	70.7	69.7	52.8	35.9
	72	84.5	8.3	79.3	62.2	45.1	28.0	-	-	76.9	9.3	75.2	58.1	40.9	23.7	-	-
3250	67	80.2	8.3	80.2	73.5	62.7	45.1	27.5	-	75.7	9.3	75.4	67.2	59.0	41.2	23.3	-
	62	80.8	8.3	80.8	80.8	80.3	62.2	44.1	26.1	74.3	9.2	74.3	74.3	74.3	58.6	40.1	21.6
	57	81.5	8.3	80.8	80.8	80.8	79.4	60.8	42.2	73.0	9.2	73.0	73.0	73.0	73.0	56.9	37.7

1. These capacities are gross ratings. For net capacity, deduct air blower motor, MBh = 3.415 x kW. Refer to the appropriate *Blower performance* table for the kW of the supply air blower motor.
2. These ratings include the condenser fan motors (total 1 kW) and the compressor motors but not the supply air blower motor.

XP090 (7.5 ton)

Air on evaporator coil		Temperature of air on condenser coil															
cfm	WB (°F)	Total capacity ¹ (MBh)	Total input (kW) ²	Sensible capacity (MBh)						Total capacity ¹ (MBh)	Total input (kW) ²	Sensible capacity (MBh)					
				Return dry bulb (°F)								Return dry bulb (°F)					
				90	85	80	75	70	65			90	85	80	75	70	65
				75°F						85°F							
1875	77	127.0	5.9	62.7	53.0	43.4	-	-	-	120.0	6.7	58.2	49.3	40.3	-	-	-
	72	115.0	5.8	73.7	63.5	53.3	43.1	-	-	108.3	6.6	70.1	60.0	49.9	39.8	-	-
	67	103.1	5.7	84.7	74.0	63.2	53.0	42.8	-	96.7	6.5	82.0	70.7	59.5	49.5	39.5	-
	62	92.8	5.6	92.8	85.5	73.1	62.4	52.8	42.6	87.0	6.4	87.0	81.8	69.1	58.9	49.2	39.3
2250	77	128.1	5.9	67.6	55.6	43.7	-	-	-	120.7	6.7	64.5	52.7	40.8	-	-	-
	72	117.2	5.8	79.8	67.8	55.8	43.7	-	-	110.3	6.6	76.6	64.6	52.6	40.5	-	-
	67	106.2	5.7	92.0	79.9	67.9	55.7	43.7	-	99.9	6.5	88.7	76.5	64.3	52.3	40.4	-
	62	97.9	5.6	97.9	91.3	80.0	67.4	55.6	43.4	92.1	6.4	92.1	87.4	76.0	63.9	52.2	40.3
2625	57	89.6	5.5	89.6	89.6	89.6	79.8	67.6	55.3	84.2	6.3	84.2	84.2	84.2	75.9	64.1	52.3
	77	129.3	6.0	72.6	58.2	43.9	-	-	-	121.4	6.7	70.9	56.1	41.3	-	-	-
	72	119.3	5.8	85.9	72.1	58.2	44.4	-	-	112.2	6.6	83.1	69.2	55.2	41.3	-	-
	67	109.3	5.7	99.3	85.9	72.5	58.5	44.5	-	103.1	6.5	95.3	82.2	69.1	55.2	41.3	-
3000	62	103.0	5.7	103.0	97.2	86.9	72.4	58.5	44.3	97.1	6.5	97.1	93.0	83.0	69.0	55.3	41.4
	57	96.7	5.6	96.7	96.7	96.7	86.8	72.5	58.1	91.1	6.4	91.1	91.1	91.1	83.1	69.2	55.4
	77	130.5	6.0	77.5	60.8	44.1	-	-	-	122.1	6.8	77.2	59.5	41.8	-	-	-
	72	121.5	5.9	92.0	76.4	60.7	45.0	-	-	114.2	6.7	89.6	73.7	57.9	42.0	-	-
3375	67	112.5	5.8	106.5	91.9	77.2	61.3	45.3	-	106.2	6.6	102.0	88.0	73.9	58.1	42.2	-
	62	108.1	5.7	108.1	103.0	93.8	77.3	61.3	45.1	102.1	6.5	102.1	98.6	90.0	74.0	58.3	42.5
	57	103.8	5.7	103.8	103.8	103.8	93.8	77.4	60.9	98.1	6.5	98.1	98.1	98.1	90.2	74.4	58.6
	72	123.6	5.9	98.2	80.6	63.1	45.6	-	-	116.1	6.7	96.1	78.3	60.5	42.7	-	-
3750	67	115.6	5.8	113.8	97.8	81.9	64.0	46.2	-	109.4	6.6	108.7	93.7	78.7	61.0	43.2	-
	62	113.2	5.8	113.2	108.9	100.6	82.3	64.2	46.0	107.2	6.6	107.2	104.2	97.0	79.1	61.4	43.6
	57	110.9	5.8	110.9	110.9	110.9	100.8	82.3	63.7	105.0	6.6	105.0	105.0	105.0	97.4	79.6	61.8
	72	125.8	5.9	104.3	84.9	65.6	46.3	-	-	118.0	6.7	102.6	82.9	63.2	43.5	-	-
1875	67	118.7	5.8	118.7	103.8	86.6	66.8	47.0	-	112.5	6.6	112.5	99.4	83.6	63.8	44.1	-
	62	118.3	5.8	118.3	114.7	107.5	87.3	67.1	46.9	112.2	6.6	112.2	109.9	103.9	84.2	64.4	44.6
	57	117.9	5.8	117.9	117.9	117.9	107.8	87.1	66.5	111.9	6.6	111.9	111.9	111.9	104.5	84.7	64.9
	72	130.5	6.0	77.5	60.8	44.1	-	-	-	122.1	6.8	77.2	59.5	41.8	-	-	-
				95°F						105°F							
1875	77	113.0	7.5	53.8	45.5	37.3	-	-	-	103.3	8.6	50.8	42.7	34.6	-	-	-
	72	101.7	7.4	66.5	56.5	46.5	36.5	-	-	93.2	8.5	63.5	53.6	43.6	33.6	-	-
	67	90.4	7.3	79.3	67.5	55.8	45.9	36.1	-	83.0	8.3	76.3	64.4	52.6	42.7	32.9	-
	62	81.3	7.2	81.3	78.1	65.0	55.3	45.6	36.0	77.0	8.3	77.0	72.9	61.5	51.9	42.2	32.5
2250	77	113.2	7.5	61.5	49.7	38.0	-	-	-	103.5	8.6	58.7	46.9	35.0	-	-	-
	72	103.4	7.4	73.4	61.4	49.4	37.4	-	-	94.9	8.5	70.1	58.1	46.2	34.3	-	-
	67	93.6	7.3	85.3	73.0	60.7	48.9	37.1	-	86.3	8.4	81.4	69.4	57.4	45.6	33.8	-
	62	86.2	7.2	86.2	83.5	72.1	60.5	48.9	37.3	81.4	8.3	81.4	78.2	68.6	56.9	45.2	33.5
2625	57	78.9	7.2	78.9	78.9	78.9	72.0	60.6	49.2	76.6	8.3	76.6	76.6	76.6	68.2	56.6	45.1
	77	113.5	7.5	69.2	54.0	38.8	-	-	-	103.6	8.6	66.7	51.1	35.5	-	-	-
	72	105.1	7.4	80.3	66.3	52.2	38.2	-	-	96.6	8.5	76.6	62.7	48.8	34.9	-	-
	67	96.8	7.3	91.4	78.5	65.7	51.9	38.1	-	89.5	8.4	86.6	74.4	62.2	48.4	34.6	-
3000	62	91.2	7.3	91.2	88.9	79.1	65.6	52.1	38.5	85.8	8.4	85.8	83.5	75.6	61.9	48.2	34.5
	57	85.6	7.2	85.6	85.6	85.6	79.3	66.0	52.8	82.2	8.4	82.2	82.2	82.2	75.4	61.8	48.2
	77	113.7	7.5	76.9	58.2	39.5	-	-	-	103.8	8.6	74.6	55.3	35.9	-	-	-
	72	106.8	7.5	87.2	71.1	55.1	39.0	-	-	98.2	8.6	83.2	67.3	51.5	35.6	-	-
3375	67	100.0	7.4	97.5	84.0	70.6	54.9	39.1	-	92.7	8.5	91.7	79.4	67.0	51.3	35.5	-
	62	96.2	7.3	96.2	94.2	86.2	70.8	55.3	39.8	90.2	8.5	90.2	88.8	82.6	66.9	51.2	35.5
	57	92.3	7.3	92.3	92.3	92.3	86.6	71.5	56.3	87.7	8.4	87.7	87.7	87.7	82.5	66.9	51.3
	72	108.6	7.5	94.0	76.0	57.9	39.9	-	-	99.9	8.6	89.7	71.9	54.1	36.3	-	-
3750	67	103.2	7.4	103.2	89.6	75.6	57.9	40.2	-	95.9	8.5	95.9	84.4	71.9	54.1	36.3	-
	62	101.1	7.4	101.1	99.6	93.3	75.9	58.5	41.1	94.6	8.5	94.6	94.1	89.6	71.9	54.2	36.5
	57	99.1	7.4	99.1	99.1	99.1	93.9	76.9	59.8	93.3	8.5	93.3	93.3	93.3	89.7	72.0	54.3
	72	110.3	7.5	100.9	80.9	60.8	40.7	-	-	101.6	8.6	96.3	76.5	56.7	37.0	-	-
3750	67	106.4	7.5	106.4	95.1	80.6	60.9	41.2	-	99.2	8.6	99.2	89.4	76.7	57.0	37.2	-
	62	106.1	7.4	106.1	105.0	100.3	81.0	61.7	42.4	99.0	8.6	99.0	99.0	96.7	76.9	57.2	37.4
	57	105.8	7.4	105.8	105.8	105.8	101.2	82.3	63.4	98.9	8.6	98.9	98.9	98.9	96.9	77.2	57.4

XP090 (7.5 ton) (Continued)

Air on evaporator coil		Temperature of air on condenser coil															
		Total capacity ¹ (MBh)	Total input (kW) ²	Sensible capacity (MBh)						Total capacity ¹ (MBh)	Total input (kW) ²	Sensible capacity (MBh)					
				Return dry bulb (°F)								Return dry bulb (°F)					
				90	85	80	75	70	65			90	85	80	75	70	65
		115°F								125°F							
1875	77	93.7	9.7	47.8	39.8	31.9	-	-	-	84.1	10.8	44.8	37.0	29.2	-	-	-
	72	84.7	9.6	60.6	50.6	40.6	30.7	-	-	76.3	10.7	57.6	47.6	37.7	27.7	-	-
	67	75.7	9.4	73.3	61.3	49.3	39.5	29.7	-	68.4	10.5	68.4	58.2	46.1	36.4	26.6	-
	62	72.8	9.4	72.8	67.7	58.1	48.4	38.8	29.1	68.5	10.5	68.5	62.5	54.6	45.0	35.4	25.7
2250	77	93.8	9.7	56.0	44.0	32.0	-	-	-	84.1	10.8	53.2	41.1	29.1	-	-	-
	72	86.4	9.6	66.8	54.9	43.0	31.2	-	-	77.9	10.7	63.5	51.7	39.9	28.1	-	-
	67	79.0	9.5	77.6	65.8	54.1	42.2	30.4	-	71.7	10.6	71.7	62.2	50.7	38.9	27.1	-
	62	76.6	9.5	76.6	72.9	65.1	53.3	41.6	29.8	71.8	10.6	71.8	67.6	61.5	49.7	37.9	26.1
2625	77	93.8	9.7	64.2	48.2	32.2	-	-	-	84.0	10.8	61.7	45.3	28.9	-	-	-
	72	88.0	9.6	73.0	59.2	45.5	31.7	-	-	79.5	10.7	69.3	55.7	42.1	28.5	-	-
	67	82.2	9.5	81.8	70.3	58.8	44.9	31.1	-	74.9	10.6	74.9	66.1	55.3	41.5	27.6	-
	62	80.5	9.5	80.5	78.1	72.0	58.2	44.3	30.5	75.1	10.6	75.1	72.7	68.5	54.5	40.4	26.4
3000	77	93.8	9.7	72.4	52.4	32.3	-	-	-	83.9	10.8	70.2	49.4	28.7	-	-	-
	72	89.6	9.7	79.2	63.5	47.9	32.2	-	-	81.0	10.8	75.2	59.8	44.3	28.8	-	-
	67	85.5	9.6	85.5	74.7	63.5	47.6	31.8	-	78.2	10.7	78.2	70.1	59.9	44.0	28.2	-
	62	84.3	9.6	84.3	83.3	79.0	63.1	47.1	31.1	78.4	10.7	78.4	77.8	75.4	59.2	43.0	26.8
3375	77	93.8	9.7	83.2	63.2	43.2	28.5	18.2	13.2	78.6	10.7	78.6	78.6	78.6	74.4	57.8	41.2
	72	91.3	9.7	85.4	67.9	50.3	32.7	-	-	82.6	10.8	81.1	63.8	46.5	29.2	-	-
	67	88.7	9.7	88.7	79.2	68.2	50.3	32.5	-	81.5	10.8	81.5	74.0	64.4	46.6	28.7	-
	62	88.2	9.6	88.2	88.2	86.0	67.9	49.9	31.8	81.7	10.8	81.7	81.7	81.7	64.0	45.5	27.1
3750	77	93.8	9.7	87.6	67.6	47.6	32.5	22.2	17.2	81.9	10.8	81.9	81.9	81.9	81.3	62.4	43.4
	72	92.9	9.7	91.6	72.2	52.7	33.3	-	-	85.4	10.8	84.2	67.9	48.7	29.6	-	-
	67	92.0	9.7	92.0	83.7	72.9	53.0	33.2	-	85.3	10.8	84.7	78.0	69.0	49.1	29.2	-
	62	92.0	9.7	92.0	92.0	92.0	72.8	52.6	32.4	85.2	10.8	84.9	84.9	84.9	68.7	48.1	27.4
57	92.0	9.7	92.0	92.0	92.0	92.0	72.0	51.5	85.2	10.8	85.2	85.2	85.2	66.9	45.5	-	

1. These capacities are gross ratings. For net capacity, deduct air blower motor, MBh = 3.415 x kW. See the appropriate *Blower performance* table for the kW of the supply air blower motor.
2. These ratings include the condenser fan motors (total 1 kW) and the compressor motors but not the supply air blower motor.

XP102 (8.5 ton)

Air on evaporator coil		Temperature of air on condenser coil															
cfm	WB (°F)	Total capacity ¹ (MBh)	Total input (kW) ²	Sensible capacity (MBh)						Total capacity ¹ (MBh)	Total input (kW) ²	Sensible capacity (MBh)					
				Return dry bulb (°F)								Return dry bulb (°F)					
				90	85	80	75	70	65			90	85	80	75	70	65
				75°F						85°F							
2125	77	135.7	6.5	66.8	55.7	44.7	-	-	-	128.4	7.4	62.1	52.1	42.2	-	-	-
	72	122.3	6.4	79.0	67.7	56.4	45.1	-	-	114.5	7.2	75.4	64.4	53.4	42.3	-	-
	67	108.9	6.3	91.1	79.6	68.1	56.4	45.2	-	100.5	7.1	88.8	76.7	64.5	53.1	42.0	-
	62	99.4	6.1	99.4	93.0	79.8	67.2	56.7	45.1	94.4	6.9	94.4	88.4	75.7	63.7	52.6	41.1
2550	77	138.2	6.5	73.1	59.3	45.5	-	-	-	130.0	7.4	70.0	56.4	42.8	-	-	-
	72	125.4	6.4	86.5	73.0	59.5	46.0	-	-	117.4	7.2	83.3	69.8	56.4	42.9	-	-
	67	112.6	6.3	100.0	86.7	73.4	59.6	46.2	-	104.7	7.1	96.6	83.3	69.9	56.3	42.7	-
	62	105.3	6.1	105.3	99.4	87.3	72.8	59.9	46.2	99.9	7.0	99.9	94.7	83.5	69.3	56.0	42.3
2975	77	140.6	6.5	79.3	62.9	46.4	-	-	-	131.6	7.4	77.9	60.7	43.5	-	-	-
	72	128.5	6.4	94.1	78.3	62.6	46.8	-	-	120.3	7.2	91.1	75.3	59.4	43.5	-	-
	67	116.3	6.3	108.9	93.8	78.7	62.8	47.1	-	109.0	7.1	104.4	89.9	75.3	59.4	43.5	-
	62	111.2	6.2	111.2	105.8	94.9	78.4	63.2	47.3	105.4	7.0	105.4	101.1	91.2	75.0	59.4	43.5
3400	77	143.1	6.5	85.5	66.4	47.3	-	-	-	133.2	7.4	85.8	65.0	44.2	-	-	-
	72	131.5	6.4	101.6	83.7	65.7	47.7	-	-	123.2	7.3	99.0	80.7	62.4	44.2	-	-
	67	120.0	6.3	117.8	100.9	84.1	66.0	48.1	-	113.2	7.1	112.2	96.4	80.7	62.5	44.3	-
	62	117.2	6.2	117.2	112.3	102.4	84.0	66.4	48.4	110.9	7.1	110.9	107.5	99.0	80.7	62.8	44.7
3825	77	146.6	6.5	98.0	79.0	58.0	47.5	37.7	27.9	135.1	7.4	95.1	75.1	55.1	43.1	33.1	23.1
	72	134.6	6.4	109.2	89.0	68.8	48.6	-	-	126.1	7.3	106.8	86.1	65.5	44.8	-	-
	67	123.7	6.3	123.7	108.0	89.4	69.2	49.0	-	117.5	7.2	117.5	103.0	86.1	65.6	45.1	-
	62	123.1	6.3	123.1	118.7	110.0	89.6	69.7	49.5	116.3	7.1	116.3	113.9	106.7	86.3	66.1	45.8
4250	77	150.6	6.5	112.0	88.0	66.0	47.0	37.0	27.0	139.1	7.4	99.1	79.1	59.1	47.1	37.1	27.1
	72	137.7	6.4	116.8	94.3	71.9	49.5	-	-	129.0	7.3	114.7	91.6	68.5	45.4	-	-
	67	131.4	6.3	131.4	115.2	94.7	72.3	50.0	-	121.7	7.2	121.7	109.6	91.5	68.7	45.9	-
	62	131.0	6.3	131.0	125.1	117.5	95.2	72.9	50.6	121.8	7.2	121.8	120.3	114.5	92.0	69.5	47.0
2125	77	121.1	8.4	57.3	48.5	39.7	-	-	-	109.5	9.5	54.8	45.9	36.9	-	-	-
	72	106.6	8.1	71.9	61.2	50.4	39.6	-	-	97.9	9.3	68.8	57.9	46.9	36.0	-	-
	67	92.1	7.9	86.5	73.8	61.0	49.9	38.7	-	86.2	9.1	82.9	69.9	56.9	45.9	34.9	-
	62	89.5	7.8	89.5	83.7	71.7	60.1	48.6	37.1	84.6	9.0	84.6	78.1	66.9	55.8	44.8	33.7
2550	77	121.8	8.3	66.9	53.5	40.1	-	-	-	110.4	9.5	64.0	50.3	36.5	-	-	-
	72	109.4	8.1	80.1	66.7	53.3	39.9	-	-	100.4	9.3	76.2	62.8	49.4	36.0	-	-
	67	96.9	7.9	93.2	79.8	66.5	52.9	39.3	-	90.3	9.1	88.5	75.4	62.3	48.8	35.3	-
	62	94.5	7.9	94.5	90.0	79.6	65.9	52.1	38.4	88.7	9.1	88.7	84.4	75.2	61.6	48.0	34.5
2975	77	122.6	8.3	76.5	58.5	40.6	-	-	-	111.3	9.4	73.2	54.7	36.1	-	-	-
	72	112.1	8.1	88.2	72.2	56.2	40.3	-	-	102.9	9.3	83.6	67.8	51.9	36.1	-	-
	67	101.7	8.0	99.9	85.9	71.9	55.9	39.9	-	94.4	9.1	94.1	80.9	67.8	51.8	35.8	-
	62	99.5	7.9	99.5	96.4	87.6	71.6	55.6	39.6	92.8	9.1	92.8	90.7	83.6	67.4	51.3	35.2
3400	77	123.3	8.2	86.0	63.5	41.0	-	-	-	112.2	9.4	82.4	59.1	35.7	-	-	-
	72	114.9	8.1	96.3	77.7	59.2	40.6	-	-	105.4	9.3	91.0	72.7	54.5	36.2	-	-
	67	106.5	8.0	106.5	92.0	77.3	59.0	40.6	-	98.5	9.2	98.5	86.4	73.2	54.7	36.2	-
	62	104.5	8.0	104.5	102.7	95.5	77.3	59.1	40.9	96.8	9.2	96.8	96.8	91.9	73.2	54.6	35.9
3825	77	122.6	8.3	76.5	58.5	40.6	-	-	-	111.3	9.4	73.2	54.7	36.1	-	-	-
	72	112.1	8.1	88.2	72.2	56.2	40.3	-	-	102.9	9.3	83.6	67.8	51.9	36.1	-	-
	67	101.7	8.0	99.9	85.9	71.9	55.9	39.9	-	94.4	9.1	94.1	80.9	67.8	51.8	35.8	-
	62	99.5	7.9	99.5	96.4	87.6	71.6	55.6	39.6	92.8	9.1	92.8	90.7	83.6	67.4	51.3	35.2
4250	77	123.3	8.2	86.0	63.5	41.0	-	-	-	112.2	9.4	82.4	59.1	35.7	-	-	-
	72	114.9	8.1	96.3	77.7	59.2	40.6	-	-	105.4	9.3	91.0	72.7	54.5	36.2	-	-
	67	106.5	8.0	106.5	92.0	77.3	59.0	40.6	-	98.5	9.2	98.5	86.4	73.2	54.7	36.2	-
	62	104.5	8.0	104.5	102.7	95.5	77.3	59.1	40.9	96.8	9.2	96.8	96.8	91.9	73.2	54.6	35.9
2125	77	117.6	8.1	104.4	83.3	62.1	40.9	-	-	107.9	9.3	98.4	77.7	57.0	36.2	-	-
	72	111.2	8.0	111.2	98.0	82.8	62.0	41.2	-	102.6	9.2	102.6	91.9	78.6	57.6	36.7	-
	67	109.5	8.0	109.5	109.1	103.4	83.0	62.6	42.2	100.9	9.2	100.9	100.9	100.2	79.0	57.8	36.6
	62	107.9	8.0	107.9	107.9	104.1	84.0	64.0	-	99.3	9.2	99.3	99.3	99.3	99.3	79.0	57.6
2550	77	120.4	8.1	112.6	88.8	65.0	41.3	-	-	110.4	9.3	105.8	82.7	59.5	36.3	-	-
	72	116.0	8.1	116.0	104.1	88.2	65.0	41.8	-	106.7	9.2	106.7	97.4	84.0	60.6	37.1	-
	67	114.5	8.0	114.5	114.5	111.4	88.8	66.1	43.5	105.0	9.2	105.0	105.0	105.0	84.9	61.1	37.4
	62	113.1	8.0	113.1	113.1	112.5	90.4	68.3	-	103.4	9.2	103.4	103.4	103.4	103.4	85.1	61.1

XP102 (8.5 ton) (Continued)

Air on evaporator coil		Temperature of air on condenser coil															
		Total capacity ¹ (MBh)	Total input (kW) ²	Sensible capacity (MBh)						Total capacity ¹ (MBh)	Total input (kW) ²	Sensible capacity (MBh)					
				Return dry bulb (°F)								Return dry bulb (°F)					
				90	85	80	75	70	65			90	85	80	75	70	65
		115°F								125°F							
2125	77	97.9	10.7	52.2	43.2	34.2	-	-	-	86.3	11.8	49.7	40.5	31.4	-	-	-
	72	89.1	10.5	65.7	54.6	43.5	32.3	-	-	80.4	11.6	62.6	51.3	40.0	28.7	-	-
	67	80.3	10.3	79.3	66.0	52.8	41.9	31.1	-	74.4	11.4	74.4	62.1	48.6	37.9	27.3	-
	62	79.6	10.2	79.6	72.4	62.1	51.5	40.9	30.4	74.7	11.5	74.7	66.8	57.3	47.2	37.1	27.0
2550	77	99.0	10.6	61.1	47.0	32.9	-	-	-	87.5	11.8	58.2	43.8	29.3	-	-	-
	72	91.4	10.5	72.4	59.0	45.6	32.1	-	-	82.3	11.6	68.6	55.1	41.7	28.2	-	-
	67	83.7	10.3	83.7	71.0	58.2	44.8	31.3	-	77.1	11.5	77.1	66.5	54.1	40.7	27.4	-
	62	82.8	10.3	82.8	78.7	70.8	57.4	44.0	30.6	76.9	11.5	76.9	73.0	66.4	53.2	39.9	26.7
2975	77	100.1	10.6	70.0	50.8	31.7	-	-	-	88.8	11.7	66.7	47.0	27.3	-	-	-
	72	93.6	10.5	79.1	63.4	47.7	31.9	-	-	84.3	11.6	74.5	58.9	43.4	27.8	-	-
	67	87.1	10.3	87.1	75.9	63.6	47.6	31.6	-	79.9	11.5	79.9	70.9	59.5	43.5	27.5	-
	62	86.0	10.3	86.0	84.9	79.6	63.3	47.0	30.7	79.2	11.5	79.2	79.2	75.6	59.1	42.7	26.3
3400	77	101.1	10.5	78.8	54.6	30.5	-	-	-	90.1	11.7	75.2	50.2	25.2	-	-	-
	72	95.8	10.5	85.8	67.8	49.8	31.7	-	-	86.3	11.6	80.5	62.8	45.0	27.3	-	-
	67	90.5	10.4	90.5	80.9	69.0	50.5	31.9	-	82.6	11.6	82.6	75.3	64.9	46.2	27.6	-
	62	89.2	10.4	89.2	89.2	88.3	69.2	50.0	30.9	81.5	11.6	81.5	81.5	81.5	65.1	45.5	25.9
3825	77	100.1	10.6	70.0	50.8	31.7	-	-	-	88.8	11.7	66.7	47.0	27.3	-	-	-
	72	93.6	10.5	79.1	63.4	47.7	31.9	-	-	84.3	11.6	74.5	58.9	43.4	27.8	-	-
	67	87.1	10.3	87.1	75.9	63.6	47.6	31.6	-	79.9	11.5	79.9	70.9	59.5	43.5	27.5	-
	62	86.0	10.3	86.0	84.9	79.6	63.3	47.0	30.7	79.2	11.5	79.2	79.2	75.6	59.1	42.7	26.3
4250	77	101.1	10.5	78.8	54.6	30.5	-	-	-	90.1	11.7	75.2	50.2	25.2	-	-	-
	72	95.8	10.5	85.8	67.8	49.8	31.7	-	-	86.3	11.6	80.5	62.8	45.0	27.3	-	-
	67	90.5	10.4	90.5	80.9	69.0	50.5	31.9	-	82.6	11.6	82.6	75.3	64.9	46.2	27.6	-
	62	89.2	10.4	89.2	89.2	88.3	69.2	50.0	30.9	81.5	11.6	81.5	81.5	81.5	65.1	45.5	25.9
3825	77	100.1	10.6	70.0	50.8	31.7	-	-	-	88.8	11.7	66.7	47.0	27.3	-	-	-
	72	93.6	10.5	79.1	63.4	47.7	31.9	-	-	84.3	11.6	74.5	58.9	43.4	27.8	-	-
	67	87.1	10.3	87.1	75.9	63.6	47.6	31.6	-	79.9	11.5	79.9	70.9	59.5	43.5	27.5	-
	62	86.0	10.3	86.0	84.9	79.6	63.3	47.0	30.7	79.2	11.5	79.2	79.2	75.6	59.1	42.7	26.3
4250	77	101.1	10.5	78.8	54.6	30.5	-	-	-	90.1	11.7	75.2	50.2	25.2	-	-	-
	72	95.8	10.5	85.8	67.8	49.8	31.7	-	-	86.3	11.6	80.5	62.8	45.0	27.3	-	-
	67	90.5	10.4	90.5	80.9	69.0	50.5	31.9	-	82.6	11.6	82.6	75.3	64.9	46.2	27.6	-
	62	89.2	10.4	89.2	89.2	88.3	69.2	50.0	30.9	81.5	11.6	81.5	81.5	81.5	65.1	45.5	25.9
3825	77	100.1	10.6	70.0	50.8	31.7	-	-	-	88.8	11.7	66.7	47.0	27.3	-	-	-
	72	93.6	10.5	79.1	63.4	47.7	31.9	-	-	84.3	11.6	74.5	58.9	43.4	27.8	-	-
	67	87.1	10.3	87.1	75.9	63.6	47.6	31.6	-	79.9	11.5	79.9	70.9	59.5	43.5	27.5	-
	62	86.0	10.3	86.0	84.9	79.6	63.3	47.0	30.7	79.2	11.5	79.2	79.2	75.6	59.1	42.7	26.3
4250	77	101.1	10.5	78.8	54.6	30.5	-	-	-	90.1	11.7	75.2	50.2	25.2	-	-	-
	72	95.8	10.5	85.8	67.8	49.8	31.7	-	-	86.3	11.6	80.5	62.8	45.0	27.3	-	-
	67	90.5	10.4	90.5	80.9	69.0	50.5	31.9	-	82.6	11.6	82.6	75.3	64.9	46.2	27.6	-
	62	89.2	10.4	89.2	89.2	88.3	69.2	50.0	30.9	81.5	11.6	81.5	81.5	81.5	65.1	45.5	25.9
3825	77	100.1	10.6	70.0	50.8	31.7	-	-	-	88.8	11.7	66.7	47.0	27.3	-	-	-
	72	93.6	10.5	79.1	63.4	47.7	31.9	-	-	84.3	11.6	74.5	58.9	43.4	27.8	-	-
	67	87.1	10.3	87.1	75.9	63.6	47.6	31.6	-	79.9	11.5	79.9	70.9	59.5	43.5	27.5	-
	62	86.0	10.3	86.0	84.9	79.6	63.3	47.0	30.7	79.2	11.5	79.2	79.2	75.6	59.1	42.7	26.3
4250	77	101.1	10.5	78.8	54.6	30.5	-	-	-	90.1	11.7	75.2	50.2	25.2	-	-	-
	72	95.8	10.5	85.8	67.8	49.8	31.7	-	-	86.3	11.6	80.5	62.8	45.0	27.3	-	-
	67	90.5	10.4	90.5	80.9	69.0	50.5	31.9	-	82.6	11.6	82.6	75.3	64.9	46.2	27.6	-
	62	89.2	10.4	89.2	89.2	88.3	69.2	50.0	30.9	81.5	11.6	81.5	81.5	81.5	65.1	45.5	25.9
3825	77	100.1	10.6	70.0	50.8	31.7	-	-	-	88.8	11.7	66.7	47.0	27.3	-	-	-
	72	93.6	10.5	79.1	63.4	47.7	31.9	-	-	84.3	11.6	74.5	58.9	43.4	27.8	-	-
	67	87.1	10.3	87.1	75.9	63.6	47.6	31.6	-	79.9	11.5	79.9	70.9	59.5	43.5	27.5	-
	62	86.0	10.3	86.0	84.9	79.6	63.3	47.0	30.7	79.2	11.5	79.2	79.2	75.6	59.1	42.7	26.3
4250	77	101.1	10.5	78.8	54.6	30.5	-	-	-	90.1	11.7	75.2	50.2	25.2	-	-	-
	72	95.8	10.5	85.8	67.8	49.8	31.7	-	-	86.3	11.6	80.5	62.8	45.0	27.3	-	-
	67	90.5	10.4	90.5	80.9	69.0	50.5	31.9	-	82.6	11.6	82.6	75.3	64.9	46.2	27.6	-
	62	89.2	10.4	89.2	89.2	88.3	69.2	50.0	30.9	81.5	11.6	81.5	81.5	81.5	65.1	45.5	25.9
3825	77	100.1	10.6	70.0	50.8	31.7	-	-	-	88.8	11.7	66.7	47.0	27.3	-	-	-
	72	93.6	10.5	79.1	63.4	47.7	31.9	-	-	84.3	11.6	74.5	58.9	43.4	27.8	-	-
	67	87.1	10.3	87.1	75.9	63.6	47.6	31.6	-	79.9	11.5	79.9	70.9	59.5	43.5	27.5	-
	62	86.0	10.3	86.0	84.9	79.6	63.3	47.0	30.7	79.2	11.5	79.2	79.2	75.6	59.1	42.7	26.3
4250	77	101.1	10.5	78.8	54.6	30.5	-	-	-	90.1	11.7	75.2	50.2	25.2	-	-	-
	72	95.8	10.5	85.8	67.8	49.8	31.7	-	-	86.3	11.6	80.5	62.8	45.0	27.3	-	-
	67	90.5	10.4	90.5	80.9	69.0	50.5	31.9	-	82.6	11.6	82.6	75.3	64.9	46.2	27.6	-
	62	89.2	10.4	89.2	89.2	88.3	69.2	50.0	30.9	81.5	11.6	81.5	81.5	81.5	65.1	45.5	25.9
3825	77	100.1	10.6	70.0	50.8	31.7	-	-	-	88.8	11.7	66.7	47.0	27.3	-	-	-
	72	93.6	10.5	79.1	63.4	47.7	31.9	-	-	84.3	11.6	74.5	58.9	43.4	27.8	-	-
	67	87.1	10.3	87.1	75.9	63.6	47.6	31.6	-	79.9	11.5	79.9	70.9	59.5	43.5	27.5	-
	62	86.0	10.3	86.0	84.9	79.6	63.3	47.0	30.7	79.2	11.5	79.2	79.2	75.6	59.1	42.7	26.3
4250	77	101.1	10.5	78.8	54.6	30.5	-	-	-	90.1	11.7	75.2	50.2	25.2	-	-	-
	72	95.8	10.5	85.8	67.8	49.8	31.7	-	-	86.3	11.6	80.5	62.8	45.0	27.3	-	-
	67	90.5	10.4	90.5	80.9	69.0	50.5	31.9	-	82.6	11.6	82.6	75.3	64.9	46.2	27.6	-
	62	89.2	10.4	89.2	89.2	88.3	69.2	50.0	30.9	81.5							

XP120 (10 ton)

Air on evaporator coil		Temperature of air on condenser coil																	
		Total capacity ¹ (MBh)	Total input (kW) ²	Sensible capacity (MBh)						Total capacity ¹ (MBh)	Total input (kW) ²	Sensible capacity (MBh)							
				Return dry bulb (°F)								Return dry bulb (°F)							
cfm	WB (°F)			90	85	80	75	70	65			90	85	80	75	70	65		
		75°F									85°F								
2500	77	150.4	7.1	73.1	62.0	50.8	-	-	-	142.1	8.2	67.8	57.7	47.7	-	-	-		
	72	138.1	7.0	90.1	77.0	63.8	50.7	-	-	129.6	8.0	86.3	73.4	60.5	47.7	-	-		
	67	125.8	6.8	107.1	92.0	76.9	63.7	50.5	-	117.2	7.8	104.8	89.1	73.4	60.2	47.1	-		
	62	117.4	6.8	117.4	104.9	89.9	74.8	63.4	50.1	112.3	7.8	112.3	100.0	86.2	71.9	59.4	46.0		
3000	77	152.9	7.1	82.9	67.4	51.8	-	-	-	143.8	8.2	79.0	63.7	48.4	-	-	-		
	72	141.7	7.0	99.2	83.5	67.7	52.0	-	-	132.9	8.0	95.5	79.9	64.2	48.5	-	-		
	67	130.5	6.9	115.5	99.6	83.6	67.7	51.7	-	121.9	7.9	112.1	96.1	80.0	64.1	48.1	-		
	62	123.6	6.8	123.6	112.6	99.5	81.9	67.3	51.2	117.8	7.8	117.8	107.6	95.8	78.8	63.3	47.0		
3500	57	116.7	6.8	116.7	116.7	115.4	99.1	82.8	66.5	113.7	7.8	113.7	113.7	111.7	95.1	78.5	61.9		
	77	155.5	7.2	92.7	72.7	52.8	-	-	-	145.5	8.2	90.2	69.6	49.1	-	-	-		
	72	145.4	7.0	108.3	89.9	71.6	53.2	-	-	136.1	8.1	104.8	86.4	67.9	49.4	-	-		
	67	135.2	6.9	124.0	107.1	90.3	71.7	53.0	-	126.7	7.9	119.4	103.1	86.7	67.9	49.1	-		
4000	62	129.8	6.9	129.8	120.3	109.1	89.0	71.1	52.2	123.4	7.9	123.4	115.1	105.5	85.8	67.2	48.1		
	57	124.4	6.9	124.4	124.4	123.7	108.6	89.3	70.0	120.0	7.9	120.0	120.0	120.0	104.8	85.3	65.9		
	77	158.0	7.2	102.5	78.1	53.8	-	-	-	147.2	8.2	101.4	75.6	49.8	-	-	-		
	72	149.0	7.1	117.4	96.4	75.4	54.4	-	-	139.4	8.1	114.1	92.8	71.6	50.3	-	-		
4500	67	140.0	7.0	132.4	114.7	97.1	75.6	54.2	-	131.5	8.0	126.8	110.1	93.4	71.7	50.1	-		
	62	136.0	7.0	136.0	128.1	118.7	96.1	75.0	53.2	128.9	8.0	128.9	122.7	115.2	92.8	71.1	49.1		
	57	132.1	6.9	132.1	132.1	132.1	118.1	95.8	73.6	126.3	8.0	126.3	126.3	126.3	114.6	92.2	69.8		
	72	152.6	7.1	126.5	102.9	79.3	55.6	-	-	142.6	8.1	123.4	99.3	75.2	51.2	-	-		
5000	67	144.7	7.0	140.8	122.3	103.8	79.6	55.5	-	136.3	8.0	134.1	117.1	100.0	75.5	51.0	-		
	62	142.2	7.0	142.2	135.8	128.3	103.2	78.9	54.2	134.5	8.0	134.5	130.3	124.8	99.7	75.0	50.1		
	57	139.8	7.0	139.8	139.8	139.8	127.6	102.4	77.1	132.6	8.1	132.6	132.6	132.6	124.3	99.0	73.7		
	72	156.3	7.1	135.6	109.4	83.1	56.9	-	-	145.9	8.1	132.6	105.8	78.9	52.0	-	-		
5500	67	149.4	7.1	149.3	129.9	110.5	83.6	56.7	-	141.1	8.1	141.1	124.1	106.7	79.4	52.0	-		
	62	148.4	7.1	148.4	143.5	137.9	110.4	82.8	55.2	140.0	8.1	140.0	137.8	134.5	106.7	78.9	51.1		
	57	147.4	7.1	147.4	147.4	137.1	108.9	80.7	-	139.0	8.1	139.0	139.0	139.0	134.0	105.8	77.6		
			95°F									105°F							
2500	77	133.7	9.2	62.4	53.5	44.6	-	-	-	121.9	10.4	61.9	51.8	41.8	-	-	-		
	72	121.1	9.0	82.4	69.8	57.2	44.6	-	-	111.2	10.3	79.6	66.6	53.7	40.8	-	-		
	67	108.5	8.8	102.5	86.2	69.9	56.8	43.7	-	100.4	10.2	97.3	81.5	65.7	52.7	39.7	-		
	62	107.1	8.8	107.1	95.2	82.5	69.0	55.4	41.9	99.4	10.2	99.4	89.2	77.6	64.6	51.6	38.5		
3000	77	134.6	9.2	75.1	60.0	45.0	-	-	-	123.4	10.4	73.5	57.4	41.3	-	-	-		
	72	124.0	9.0	91.9	76.3	60.7	45.1	-	-	114.4	10.3	88.2	72.4	56.7	41.0	-	-		
	67	113.4	8.9	108.7	92.6	76.5	60.4	44.4	-	105.4	10.2	102.9	87.5	72.2	56.2	40.3	-		
	62	112.0	8.9	112.0	102.6	92.2	75.8	59.3	42.9	104.3	10.2	104.3	96.6	87.6	71.5	55.3	39.2		
3500	57	110.6	8.9	110.6	110.6	108.0	91.1	74.2	57.4	103.2	10.2	103.2	103.2	103.1	86.7	70.3	54.0		
	77	135.5	9.2	87.7	66.5	45.3	-	-	-	124.8	10.4	85.1	62.9	40.7	-	-	-		
	72	126.9	9.1	101.3	82.8	64.2	45.6	-	-	117.6	10.3	96.8	78.2	59.7	41.2	-	-		
	67	118.2	8.9	114.9	99.0	83.1	64.1	45.2	-	110.3	10.2	108.5	93.6	78.7	59.8	40.9	-		
4000	62	116.9	8.9	116.9	109.9	101.9	82.6	63.3	43.9	109.3	10.2	109.3	104.0	97.7	78.4	59.1	39.8		
	57	115.6	8.9	115.6	115.6	115.6	101.1	81.4	61.7	108.2	10.2	108.2	108.2	108.2	97.0	77.3	57.6		
	77	136.4	9.2	100.4	73.0	45.7	-	-	-	126.3	10.3	96.7	68.5	40.2	-	-	-		
	72	129.7	9.1	110.8	89.2	67.7	46.2	-	-	120.8	10.3	105.3	84.0	62.7	41.4	-	-		
4500	67	123.0	9.0	121.2	105.4	89.6	67.8	45.9	-	115.3	10.2	114.0	99.6	85.2	63.3	41.5	-		
	62	121.8	9.0	121.8	117.3	111.6	89.4	67.2	45.0	114.2	10.2	114.2	111.5	107.7	85.3	62.8	40.4		
	57	120.5	9.0	120.5	120.5	120.5	111.0	88.5	65.9	113.1	10.3	113.1	113.1	113.1	107.2	84.2	61.2		
	72	132.6	9.1	120.2	95.7	71.2	46.7	-	-	124.0	10.3	113.9	89.8	65.7	41.7	-	-		
5000	67	127.9	9.0	127.4	111.8	96.2	71.4	46.6	-	120.2	10.2	119.6	105.7	91.7	66.9	42.1	-		
	62	126.7	9.1	126.7	124.7	121.3	96.2	71.1	46.0	119.2	10.2	119.2	118.9	117.7	92.2	66.6	41.0		
	57	125.5	9.1	125.5	125.5	125.5	121.0	95.6	70.2	118.1	10.3	118.1	118.1	118.1	117.4	91.1	64.8		
	72	135.5	9.1	129.6	102.2	74.7	47.2	-	-	127.2	10.3	122.5	95.6	68.8	41.9	-	-		
5500	67	132.7	9.1	132.7	118.2	102.8	75.1	47.4	-	125.2	10.2	125.1	111.7	98.3	70.5	42.7	-		
	62	131.6	9.1	131.6	131.6	131.0	103.0	75.0	47.1	124.1	10.2	124.1	124.1	124.1	99.1	70.3	41.6		
	57	130.5	9.2	130.5	130.5	130.5	130.5	102.7	74.5	123.0	10.3	123.0	123.0	123.0	98.0	68.4			

XP120 (10 ton) (Continued)

Air on evaporator coil		Temperature of air on condenser coil															
		Total capacity ¹ (MBh)	Total input (kW) ²	Sensible capacity (MBh)						Total capacity ¹ (MBh)	Total input (kW) ²	Sensible capacity (MBh)					
				Return dry bulb (°F)								Return dry bulb (°F)					
				90	85	80	75	70	65			90	85	80	75	70	65
		115°F								125°F							
2500	77	110.0	11.6	61.3	50.1	38.9	-	-	-	98.2	13.1	60.7	48.4	36.1	-	-	-
	72	101.2	11.7	76.7	63.5	50.2	36.9	-	-	91.2	13.1	73.9	60.3	46.7	33.1	-	-
	67	92.4	11.7	92.2	76.8	61.5	48.6	35.7	-	84.3	13.1	84.3	72.1	57.2	44.5	31.7	-
	62	91.6	11.7	91.6	83.2	72.7	60.2	47.7	35.2	83.9	13.1	83.9	77.3	67.8	55.8	43.9	31.9
3000	77	112.1	11.6	71.9	54.7	37.5	-	-	-	100.8	13.0	70.3	52.0	33.8	-	-	-
	72	104.7	11.6	84.5	68.6	52.7	36.8	-	-	95.1	13.0	80.8	64.7	48.7	32.7	-	-
	67	97.4	11.6	97.1	82.5	67.9	52.0	36.1	-	89.5	13.0	89.5	77.4	63.6	47.8	32.0	-
	62	96.6	11.6	96.6	90.7	83.1	67.2	51.3	35.4	88.9	13.0	88.9	84.7	78.5	62.9	47.3	31.7
3500	77	114.1	11.6	82.4	59.3	36.1	-	-	-	103.4	12.8	79.8	55.7	31.6	-	-	-
	72	108.3	11.5	92.2	73.7	55.2	36.8	-	-	99.0	12.8	87.6	69.2	50.8	32.4	-	-
	67	102.5	11.5	102.0	88.2	74.3	55.5	36.6	-	94.6	12.8	94.6	82.7	70.0	51.2	32.3	-
	62	101.6	11.6	101.6	98.1	93.4	74.2	54.9	35.6	94.0	12.9	94.0	92.2	89.2	70.0	50.7	31.4
4000	77	116.1	11.5	93.0	63.9	34.8	-	-	-	106.0	12.7	89.3	59.3	29.3	-	-	-
	72	111.8	11.5	99.9	78.8	57.8	36.7	-	-	102.9	12.7	94.5	73.7	52.8	32.0	-	-
	67	107.5	11.5	106.9	93.8	80.8	58.9	37.1	-	99.8	12.7	99.7	88.0	76.4	54.5	32.6	-
	62	106.6	11.5	106.6	105.6	103.8	81.1	58.5	35.8	99.0	12.7	99.0	99.0	99.0	77.0	54.1	31.2
4500	77	115.4	11.4	107.6	84.0	60.3	36.6	-	-	106.8	12.6	101.4	78.1	54.9	31.6	-	-
	72	112.6	11.4	111.7	99.5	87.2	62.4	37.5	-	105.0	12.6	103.9	93.3	82.8	57.9	33.0	-
	67	111.6	11.4	111.6	111.6	111.6	88.1	62.1	36.0	104.1	12.6	103.8	103.8	103.8	84.1	57.5	31.0
	62	110.6	11.4	110.6	110.6	110.6	110.6	86.6	59.3	103.2	12.6	103.2	103.2	103.2	103.2	82.1	53.9
5000	77	118.9	11.4	115.4	89.1	62.8	36.6	-	-	110.7	12.5	108.2	82.6	56.9	31.3	-	-
	72	117.7	11.3	116.6	105.2	93.7	65.8	38.0	-	110.1	12.4	108.1	98.6	89.1	61.2	33.3	-
	67	116.6	11.3	116.5	116.5	116.5	95.1	65.6	36.2	109.1	12.4	108.1	108.1	108.1	91.1	60.9	30.7
	62	115.6	11.4	115.6	115.6	115.6	115.6	93.3	62.3	108.2	12.4	108.0	108.0	108.0	108.0	88.6	56.1

1. These capacities are gross ratings. For net capacity, deduct air blower motor, MBh = 3.415 x kW. See the appropriate *Blower performance* table for the kW of the supply air blower motor.
2. These ratings include the condenser fan motors (total 1 kW) and the compressor motors but not the supply air blower motor.

XP150 (12.5 ton)

Air on evaporator coil		Temperature of air on condenser coil																	
cfm	WB (°F)	Total capacity ¹ (MBh)	Total input (kW) ²	Sensible capacity (MBh)						Total capacity ¹ (MBh)	Total input (kW) ²	Sensible capacity (MBh)							
				Return dry bulb (°F)								Return dry bulb (°F)							
				90	85	80	75	70	65			90	85	80	75	70	65		
				75°F								85°F							
3125	77	185.5	8.6	95.9	80.6	65.3	-	-	-	175.1	9.6	89.5	75.5	61.5	-	-	-		
	72	171.6	8.4	114.9	98.5	82.0	65.6	-	-	162.9	9.4	111.3	94.8	78.2	61.7	-	-		
	67	157.7	8.2	134.0	116.4	98.7	81.4	65.3	-	150.8	9.2	133.2	114.1	95.0	77.8	61.2	-		
	62	146.9	8.1	146.9	132.9	115.4	95.4	81.5	64.5	144.1	9.1	144.1	128.1	111.7	93.0	77.4	60.2		
3750	77	186.1	8.6	101.7	82.2	62.7	-	-	-	176.3	9.6	96.7	77.9	59.1	-	-	-		
	72	173.4	8.4	121.4	102.4	83.4	64.5	-	-	164.8	9.4	118.1	99.0	79.8	60.7	-	-		
	67	160.7	8.3	141.1	122.6	104.2	84.3	65.3	-	153.3	9.3	139.4	120.0	100.5	80.6	61.3	-		
	62	152.3	8.2	152.3	139.9	124.9	102.6	85.2	65.3	148.4	9.2	148.4	135.1	121.1	99.9	81.0	61.0		
4375	77	186.7	8.6	107.5	83.8	60.1	-	-	-	177.5	9.6	104.0	80.4	56.8	-	-	-		
	72	175.2	8.5	127.8	106.3	84.8	63.4	-	-	166.7	9.5	124.8	103.1	81.4	59.7	-	-		
	67	163.6	8.3	148.1	128.9	109.6	87.1	65.4	-	155.9	9.3	145.7	125.8	106.0	83.5	61.3	-		
	62	157.6	8.3	157.6	146.9	134.3	109.8	88.9	66.1	152.7	9.3	152.7	142.1	130.6	106.7	84.7	61.8		
5000	77	187.4	8.7	113.3	85.4	57.5	-	-	-	178.7	9.6	111.3	82.9	54.5	-	-	-		
	72	176.9	8.5	134.2	110.2	86.3	62.3	-	-	168.5	9.5	131.6	107.3	83.0	58.7	-	-		
	67	166.5	8.4	155.2	135.1	115.0	90.0	65.4	-	158.4	9.4	151.9	131.7	111.5	86.3	61.4	-		
	62	163.0	8.4	163.0	153.9	143.8	117.0	92.6	67.0	157.0	9.4	157.0	149.2	140.0	113.6	88.4	62.5		
5625	77	186.7	8.6	107.5	83.8	60.1	-	-	-	177.5	9.6	104.0	80.4	56.8	-	-	-		
	72	175.2	8.5	127.8	106.3	84.8	63.4	-	-	166.7	9.5	124.8	103.1	81.4	59.7	-	-		
	67	163.6	8.3	148.1	128.9	109.6	87.1	65.4	-	155.9	9.3	145.7	125.8	106.0	83.5	61.3	-		
	62	157.6	8.3	157.6	146.9	134.3	109.8	88.9	66.1	152.7	9.3	152.7	142.1	130.6	106.7	84.7	61.8		
6250	77	187.4	8.7	113.3	85.4	57.5	-	-	-	178.7	9.6	111.3	82.9	54.5	-	-	-		
	72	176.9	8.5	134.2	110.2	86.3	62.3	-	-	168.5	9.5	131.6	107.3	83.0	58.7	-	-		
	67	166.5	8.4	155.2	135.1	115.0	90.0	65.4	-	158.4	9.4	151.9	131.7	111.5	86.3	61.4	-		
	62	163.0	8.4	163.0	153.9	143.8	117.0	92.6	67.0	157.0	9.4	157.0	149.2	140.0	113.6	88.4	62.5		
3125	77	186.1	8.6	101.7	82.2	62.7	-	-	-	176.3	9.6	96.7	77.9	59.1	-	-	-		
	72	173.4	8.4	121.4	102.4	83.4	64.5	-	-	164.8	9.4	118.1	99.0	79.8	60.7	-	-		
	67	160.7	8.3	141.1	122.6	104.2	84.3	65.3	-	153.3	9.3	139.4	120.0	100.5	80.6	61.3	-		
	62	152.3	8.2	152.3	139.9	124.9	102.6	85.2	65.3	148.4	9.2	148.4	135.1	121.1	99.9	81.0	61.0		
3750	77	186.7	8.6	107.5	83.8	60.1	-	-	-	177.5	9.6	104.0	80.4	56.8	-	-	-		
	72	175.2	8.5	127.8	106.3	84.8	63.4	-	-	166.7	9.5	124.8	103.1	81.4	59.7	-	-		
	67	163.6	8.3	148.1	128.9	109.6	87.1	65.4	-	155.9	9.3	145.7	125.8	106.0	83.5	61.3	-		
	62	157.6	8.3	157.6	146.9	134.3	109.8	88.9	66.1	152.7	9.3	152.7	142.1	130.6	106.7	84.7	61.8		
4375	77	186.7	8.6	107.5	83.8	60.1	-	-	-	177.5	9.6	104.0	80.4	56.8	-	-	-		
	72	175.2	8.5	127.8	106.3	84.8	63.4	-	-	166.7	9.5	124.8	103.1	81.4	59.7	-	-		
	67	163.6	8.3	148.1	128.9	109.6	87.1	65.4	-	155.9	9.3	145.7	125.8	106.0	83.5	61.3	-		
	62	157.6	8.3	157.6	146.9	134.3	109.8	88.9	66.1	152.7	9.3	152.7	142.1	130.6	106.7	84.7	61.8		
5000	77	187.4	8.7	113.3	85.4	57.5	-	-	-	178.7	9.6	111.3	82.9	54.5	-	-	-		
	72	176.9	8.5	134.2	110.2	86.3	62.3	-	-	168.5	9.5	131.6	107.3	83.0	58.7	-	-		
	67	166.5	8.4	155.2	135.1	115.0	90.0	65.4	-	158.4	9.4	151.9	131.7	111.5	86.3	61.4	-		
	62	163.0	8.4	163.0	153.9	143.8	117.0	92.6	67.0	157.0	9.4	157.0	149.2	140.0	113.6	88.4	62.5		
5625	77	186.7	8.6	107.5	83.8	60.1	-	-	-	177.5	9.6	104.0	80.4	56.8	-	-	-		
	72	175.2	8.5	127.8	106.3	84.8	63.4	-	-	166.7	9.5	124.8	103.1	81.4	59.7	-	-		
	67	163.6	8.3	148.1	128.9	109.6	87.1	65.4	-	155.9	9.3	145.7	125.8	106.0	83.5	61.3	-		
	62	157.6	8.3	157.6	146.9	134.3	109.8	88.9	66.1	152.7	9.3	152.7	142.1	130.6	106.7	84.7	61.8		
6250	77	187.4	8.7	113.3	85.4	57.5	-	-	-	178.7	9.6	111.3	82.9	54.5	-	-	-		
	72	176.9	8.5	134.2	110.2	86.3	62.3	-	-	168.5	9.5	131.6	107.3	83.0	58.7	-	-		
	67	166.5	8.4	155.2	135.1	115.0	90.0	65.4	-	158.4	9.4	151.9	131.7	111.5	86.3	61.4	-		
	62	163.0	8.4	163.0	153.9	143.8	117.0	92.6	67.0	157.0	9.4	157.0	149.2	140.0	113.6	88.4	62.5		
3125	77	186.1	8.6	101.7	82.2	62.7	-	-	-	176.3	9.6	96.7	77.9	59.1	-	-	-		
	72	173.4	8.4	121.4	102.4	83.4	64.5	-	-	164.8	9.4	118.1	99.0	79.8	60.7	-	-		
	67	160.7	8.3	141.1	122.6	104.2	84.3	65.3	-	153.3	9.3	139.4	120.0	100.5	80.6	61.3	-		
	62	152.3	8.2	152.3	139.9	124.9	102.6	85.2	65.3	148.4	9.2	148.4	135.1	121.1	99.9	81.0	61.0		
3750	77	186.7	8.6	107.5	83.8	60.1	-	-	-	177.5	9.6	104.0	80.4	56.8	-	-	-		
	72	175.2	8.5	127.8	106.3	84.8	63.4	-	-	166.7	9.5	124.8	103.1	81.4	59.7	-	-		
	67	163.6	8.3	148.1	128.9	109.6	87.1	65.4	-	155.9	9.3	145.7	125.8	106.0	83.5	61.3	-		
	62	157.6	8.3	157.6	146.9	134.3	109.8	88.9	66.1	152.7	9.3	152.7	142.1	130.6	106.7	84.7	61.8		
4375	77	186.7	8.6	107.5	83.8	60.1	-	-	-	177.5	9.6	104.0	80.4	56.8	-	-	-		
	72	175.2	8.5	127.8	106.3	84.8	63.4	-	-	166.7	9.5	124.8	103.1	81.4	59.7	-	-		
	67	163.6	8.3	148.1	128.9	109.6	87.1	65.4	-	155.9	9.3	145.7	125.8	106.0	83.5	61.3	-		
	62	157.6	8.3	157.6	146.9	134.3	109.8	88.9	66.1	152.7	9.3	152.7	142.1	130.6	106.7	84.7	61.8		
5000	77	187.4	8.7	113.3	85.4	57.5	-	-	-	178.7	9.6	111.3	82.9	54.5	-	-	-		
	72	176.9	8.5	134.2	110.2	86.3	62.3	-	-	168.5	9.5	131.6	107.3	83.0	58.7	-	-		
	67	166.5	8.4	155.2	135.1	115.0	90.0	65.4	-	158.4	9.4	151.9	131.7	111.5	86.3	61.4	-		
	62	163.0	8.4	163.0	153.9	143.8	117.0	92.6	67.0	157.0	9.4	157.0	149.2	140.0	113.6	88.4	62.5		
5625	77	186.7	8.6	107.5	83.8	60.1	-	-	-	177.5	9.6	104.0	80.4	56.8	-	-	-		
	72	175.2	8.5	127.8	106.3	84.8	63.4	-	-	166.7	9.5	124.8	103.1	81.4	59.7	-	-		
	67	163.6	8.3	148.1	128.9	109.6	87.1	65.4	-	155.9	9.3	145.7	125.8	106.0	83.5	61.3	-		
	62	157.6	8.3	157.6	146.9	134.3	109.8	88.9	66.1	152.7	9.3	152.7	142.1	130.6	106.7	84.7	61.8		
6250	77	187.4	8.7	113.3	85.4	57.5	-	-	-	178.7	9.6	111.3	82.9	54.5	-	-	-		
	72	176.9	8.5	134.2	110.2	86.3	62.3	-											

XP150 (12.5 ton) (Continued)

Air on evaporator coil		Temperature of air on condenser coil															
cfm	WB (°F)	Total capacity ¹ (MBh)	Total input (kW) ²	Sensible capacity (MBh)						Total capacity ¹ (MBh)	Total input (kW) ²	Sensible capacity (MBh)					
				Return dry bulb (°F)								Return dry bulb (°F)					
				90	85	80	75	70	65			90	85	80	75	70	65
				115°F						125°F							
3125	77	139.7	13.3	76.6	61.6	46.7	-	-	-	127.3	14.7	73.4	57.3	41.2	-	-	-
	72	130.2	13.2	97.9	80.9	63.9	46.8	-	-	118.1	14.6	93.0	75.8	58.6	41.4	-	-
	67	124.2	13.0	119.2	100.1	81.0	63.6	46.1	-	114.5	14.4	108.9	94.3	76.0	58.3	40.5	-
	62	122.3	13.0	120.9	109.6	98.2	80.3	62.3	44.4	112.9	14.4	112.0	102.7	93.3	75.1	56.9	38.7
3750	77	140.9	13.3	86.7	65.9	45.0	-	-	-	128.2	14.7	84.2	61.9	39.7	-	-	-
	72	132.4	13.2	105.0	85.4	65.8	46.2	-	-	120.6	14.6	100.1	80.3	60.6	40.9	-	-
	67	129.1	13.1	123.2	104.9	86.6	66.4	46.2	-	120.4	14.4	112.9	98.7	81.5	61.1	40.7	-
	62	128.6	13.0	124.8	116.1	107.4	86.6	65.8	45.0	120.0	14.4	115.5	109.0	102.5	81.4	60.3	39.2
4375	77	142.1	13.3	96.8	70.1	43.3	-	-	-	129.1	14.7	94.9	66.6	38.2	-	-	-
	72	134.7	13.2	112.0	89.9	67.8	45.6	-	-	123.0	14.6	107.1	84.9	62.6	40.4	-	-
	67	132.0	13.1	127.3	109.8	92.2	69.3	46.4	-	123.0	14.5	116.9	103.2	87.1	64.0	40.9	-
	62	131.2	13.1	128.7	122.7	116.7	93.0	69.3	45.6	122.9	14.5	119.1	115.3	111.6	87.6	63.7	39.7
5000	77	143.3	13.3	106.9	74.3	41.6	-	-	-	130.0	14.7	105.7	71.2	36.6	-	-	-
	72	137.0	13.3	119.1	94.4	69.7	45.0	-	-	125.8	14.7	114.2	89.4	64.7	39.9	-	-
	67	130.7	13.2	130.7	114.6	97.8	72.2	46.5	-	125.2	14.6	120.8	107.7	92.7	66.9	41.1	-
	62	132.5	13.2	132.5	129.3	125.9	99.3	72.8	46.2	123.3	14.6	122.6	121.7	120.7	93.9	67.1	40.2
5625	77	144.1	13.3	111.1	79.1	45.1	-	-	-	131.1	14.7	107.7	74.2	37.7	-	-	-
	72	137.0	13.3	119.1	94.4	69.7	45.0	-	-	125.8	14.7	114.2	89.4	64.7	39.9	-	-
	67	130.7	13.2	130.7	114.6	97.8	72.2	46.5	-	125.2	14.6	120.8	107.7	92.7	66.9	41.1	-
	62	132.5	13.2	132.5	129.3	125.9	99.3	72.8	46.2	123.3	14.6	122.6	121.7	120.7	93.9	67.1	40.2
6250	77	144.1	13.3	111.1	79.1	45.1	-	-	-	131.1	14.7	107.7	74.2	37.7	-	-	-
	72	137.0	13.3	119.1	94.4	69.7	45.0	-	-	125.8	14.7	114.2	89.4	64.7	39.9	-	-
	67	130.7	13.2	130.7	114.6	97.8	72.2	46.5	-	125.2	14.6	120.8	107.7	92.7	66.9	41.1	-
	62	132.5	13.2	132.5	129.3	125.9	99.3	72.8	46.2	123.3	14.6	122.6	121.7	120.7	93.9	67.1	40.2
6250	77	144.1	13.3	111.1	79.1	45.1	-	-	-	131.1	14.7	107.7	74.2	37.7	-	-	-
	72	137.0	13.3	119.1	94.4	69.7	45.0	-	-	125.8	14.7	114.2	89.4	64.7	39.9	-	-
	67	130.7	13.2	130.7	114.6	97.8	72.2	46.5	-	125.2	14.6	120.8	107.7	92.7	66.9	41.1	-
	62	132.5	13.2	132.5	129.3	125.9	99.3	72.8	46.2	123.3	14.6	122.6	121.7	120.7	93.9	67.1	40.2
6250	77	144.1	13.3	111.1	79.1	45.1	-	-	-	131.1	14.7	107.7	74.2	37.7	-	-	-
	72	137.0	13.3	119.1	94.4	69.7	45.0	-	-	125.8	14.7	114.2	89.4	64.7	39.9	-	-
	67	130.7	13.2	130.7	114.6	97.8	72.2	46.5	-	125.2	14.6	120.8	107.7	92.7	66.9	41.1	-
	62	132.5	13.2	132.5	129.3	125.9	99.3	72.8	46.2	123.3	14.6	122.6	121.7	120.7	93.9	67.1	40.2
6250	77	144.1	13.3	111.1	79.1	45.1	-	-	-	131.1	14.7	107.7	74.2	37.7	-	-	-
	72	137.0	13.3	119.1	94.4	69.7	45.0	-	-	125.8	14.7	114.2	89.4	64.7	39.9	-	-
	67	130.7	13.2	130.7	114.6	97.8	72.2	46.5	-	125.2	14.6	120.8	107.7	92.7	66.9	41.1	-
	62	132.5	13.2	132.5	129.3	125.9	99.3	72.8	46.2	123.3	14.6	122.6	121.7	120.7	93.9	67.1	40.2
6250	77	144.1	13.3	111.1	79.1	45.1	-	-	-	131.1	14.7	107.7	74.2	37.7	-	-	-
	72	137.0	13.3	119.1	94.4	69.7	45.0	-	-	125.8	14.7	114.2	89.4	64.7	39.9	-	-
	67	130.7	13.2	130.7	114.6	97.8	72.2	46.5	-	125.2	14.6	120.8	107.7	92.7	66.9	41.1	-
	62	132.5	13.2	132.5	129.3	125.9	99.3	72.8	46.2	123.3	14.6	122.6	121.7	120.7	93.9	67.1	40.2
6250	77	144.1	13.3	111.1	79.1	45.1	-	-	-	131.1	14.7	107.7	74.2	37.7	-	-	-
	72	137.0	13.3	119.1	94.4	69.7	45.0	-	-	125.8	14.7	114.2	89.4	64.7	39.9	-	-
	67	130.7	13.2	130.7	114.6	97.8	72.2	46.5	-	125.2	14.6	120.8	107.7	92.7	66.9	41.1	-
	62	132.5	13.2	132.5	129.3	125.9	99.3	72.8	46.2	123.3	14.6	122.6	121.7	120.7	93.9	67.1	40.2
6250	77	144.1	13.3	111.1	79.1	45.1	-	-	-	131.1	14.7	107.7	74.2	37.7	-	-	-
	72	137.0	13.3	119.1	94.4	69.7	45.0	-	-	125.8	14.7	114.2	89.4	64.7	39.9	-	-
	67	130.7	13.2	130.7	114.6	97.8	72.2	46.5	-	125.2	14.6	120.8	107.7	92.7	66.9	41.1	-
	62	132.5	13.2	132.5	129.3	125.9	99.3	72.8	46.2	123.3	14.6	122.6	121.7	120.7	93.9	67.1	40.2
6250	77	144.1	13.3	111.1	79.1	45.1	-	-	-	131.1	14.7	107.7	74.2	37.7	-	-	-
	72	137.0	13.3	119.1	94.4	69.7	45.0	-	-	125.8	14.7	114.2	89.4	64.7	39.9	-	-
	67	130.7	13.2	130.7	114.6	97.8	72.2	46.5	-	125.2	14.6	120.8	107.7	92.7	66.9	41.1	-
	62	132.5	13.2	132.5	129.3	125.9	99.3	72.8	46.2	123.3	14.6	122.6	121.7	120.7	93.9	67.1	40.2
6250	77	144.1	13.3	111.1	79.1	45.1	-	-	-	131.1	14.7	107.7	74.2	37.7	-	-	-
	72	137.0	13.3	119.1	94.4	69.7	45.0	-	-	125.8	14.7	114.2	89.4	64.7	39.9	-	-
	67	130.7	13.2	130.7	114.6	97.8	72.2	46.5	-	125.2	14.6	120.8	107.7	92.7	66.9	41.1	-
	62	132.5	13.2	132.5	129.3	125.9	99.3	72.8	46.2	123.3	14.6	122.6	121.7	120.7	93.9	67.1	40.2
6250	77	144.1	13.3	111.1	79.1	45.1	-	-	-	131.1	14.7	107.7	74.2	37.7	-	-	-
	72	137.0	13.3	119.1	94.4	69.7	45.0	-	-	125.8	14.7	114.2	89.4	64.7	39.9	-	-
	67	130.7	13.2	130.7	114.6	97.8	72.2	46.5	-	125.2	14.6	120.8	107.7	92.7	66.9	41.1	-
	62	132.5	13.2	132.5	129.3	125.9	99.3	72.8	46.2	123.3	14.6	122.6	121.7	120.7	93.9	67.1	40.2
6250	77	144.1	13.3	111.1	79.1	45.1	-	-	-	131.1	14.7	107.7	74.2	37.7	-	-	-
	72	137.0	13.3	119.1	94.4	69.7	45.0	-	-	125.8	14.7	114.2	89.4	64.7	39.9	-	-
	67	130.7	13.2	130.7	114.6	97.8	72.2	46.5	-	125.2	14.6	120.8	107.7	92.7	66.9	41.1	-
	62	132.5	13.2	132.5	129.3	125.9	99.3	72.8	46.2	123.3	14.6	122.6	121.7	120.7	93.9	67.1	40.2
6250	77	144.1	13.3	111.1	79.1	45.1	-	-	-	131.1	14.7	107.7	74.2	37.7	-	-	-
	72	137.0	13.3	119.1	94.4	69.7	45.0	-	-	125.8	14.7	114.2	89.4	64.7	39.9	-	-
	67	130.7	13.2	130.7	114.6	97.8	72.2	46.5	-	125.2	14.6	120.8	107.7	92.7	66.9	41.1	-
	62	132.5	13.2	132.5	129.3	125.9	99.3	72.8	46.2	123.3	14.6	122.6	121.7	120.7	93.9	67.1	40.2
6250	77	144.1	13.3	111.1	79.1	45.1	-	-	-	131.1	14.7	107.7	74.2	37.7	-	-	-
	72	137.0	13.3	11													

XP078-150 Heating Capacities

XP078-150

Size (ton)	Model	Air over evaporator coil		Capacity ¹ and kW	Outdoor temperature (°F @ 72% RH)									
		CFM	DB (°F)		-10	0	10	20	30	40	50	60		
078 (6.5)	XP	1950	55	MBH	9.3	21.2	33.1	45.0	56.9	68.9	80.8	92.7		
				kW	4.8	4.9	5.0	5.1	5.2	5.4	5.5	5.6		
			70	MBH	4.0	15.9	27.8	39.7	51.7	63.6	75.5	87.4		
				kW	5.6	5.8	5.9	6.0	6.1	6.2	6.3	6.5		
			80	MBH	0.2	12.1	24.1	36.0	47.9	59.8	71.7	83.6		
				kW	6.3	6.5	6.6	6.7	6.8	6.9	7.0	7.2		
		2600	55	MBH	10.7	22.6	34.5	46.4	58.3	70.3	82.2	94.1		
				kW	4.1	4.3	4.4	4.5	4.6	4.7	4.8	5.0		
			70	MBH	5.4	17.3	29.2	41.1	53.0	65.0	76.9	88.8		
				kW	5.0	5.1	5.2	5.4	5.5	5.6	5.7	5.8		
			80	MBH	1.6	13.5	25.5	37.4	49.3	61.2	73.1	85.0		
				kW	5.7	5.8	5.9	6.1	6.2	6.3	6.4	6.5		
		3250	55	MBH	10.5	22.5	34.4	46.3	58.2	70.1	82.0	94.0		
				kW	3.7	3.9	4.0	4.1	4.2	4.3	4.4	4.6		
			70	MBH	5.3	17.2	29.1	41.0	52.9	64.8	76.8	88.7		
				kW	4.6	4.7	4.8	5.0	5.1	5.2	5.3	5.4		
			80	MBH	1.5	13.4	25.3	37.3	49.2	61.1	73.0	84.9		
				kW	5.3	5.4	5.5	5.7	5.8	5.9	6.0	6.1		
		090 (7.5)	XP	2250	55	MBH	41.8	49.8	57.8	65.8	73.8	81.8	89.9	97.9
						kW	5.1	5.3	5.4	5.5	5.6	5.7	5.8	5.9
					70	MBH	31.3	39.3	47.3	55.3	63.3	71.3	79.4	87.4
						kW	6.0	6.1	6.3	6.4	6.5	6.6	6.7	6.8
					80	MBH	13.5	21.6	29.6	37.6	45.6	53.6	61.6	69.6
						kW	6.4	6.5	6.6	6.7	6.9	7.0	7.1	7.2
3000	55			MBH	38.1	46.1	54.1	62.1	70.1	78.2	86.2	94.2		
				kW	4.3	4.4	4.5	4.6	4.8	4.9	5.0	5.1		
	70			MBH	28.0	36.0	44.0	52.1	60.1	68.1	76.1	84.1		
				kW	5.3	5.4	5.5	5.7	5.8	5.9	6.0	6.1		
	80			MBH	10.3	18.3	26.3	34.3	42.3	50.3	58.3	66.3		
				kW	5.7	5.8	5.9	6.0	6.1	6.2	6.4	6.5		
3750	55			MBH	46.1	54.1	62.2	70.2	78.2	86.2	94.2	102.2		
				kW	4.2	4.3	4.4	4.5	4.6	4.7	4.8	4.9		
	70			MBH	35.6	43.6	51.7	59.7	67.7	75.7	83.7	91.7		
				kW	5.1	5.2	5.3	5.4	5.5	5.6	5.7	5.8		
	80			MBH	17.9	25.9	33.9	41.9	50.0	58.0	66.0	74.0		
				kW	5.4	5.6	5.7	5.8	5.9	6.0	6.1	6.2		
102 (8.5)	XP			2550	55	MBH	17.6	31.2	44.7	58.3	71.9	85.4	99.0	112.6
						kW	5.1	5.3	5.5	5.7	5.9	6.0	6.2	6.4
					70	MBH	12.4	26.0	39.6	53.1	66.7	80.3	93.8	107.4
						kW	6.2	6.4	6.6	6.8	7.0	7.1	7.3	7.5
					80	MBH	8.9	22.5	36.0	49.6	63.2	76.7	90.3	103.8
						kW	7.0	7.2	7.4	7.6	7.8	7.9	8.1	8.3
		3400	55	MBH	20.3	33.9	47.5	61.0	74.6	88.2	101.7	115.3		
				kW	4.5	4.7	4.9	5.1	5.3	5.4	5.6	5.8		
			70	MBH	14.9	28.4	42.0	55.6	69.1	82.7	96.3	109.8		
				kW	5.5	5.7	5.9	6.1	6.3	6.5	6.6	6.8		
			80	MBH	11.3	24.9	38.5	52.0	65.6	79.2	92.7	106.3		
				kW	6.4	6.5	6.7	6.9	7.1	7.3	7.4	7.6		
		4250	55	MBH	19.6	33.2	46.8	60.3	73.9	87.5	101.0	114.6		
				kW	4.0	4.2	4.4	4.6	4.7	4.9	5.1	5.3		
			70	MBH	14.5	28.0	41.6	55.2	68.7	82.3	95.9	109.4		
				kW	5.1	5.3	5.5	5.7	5.8	6.0	6.2	6.4		
			80	MBH	10.9	24.5	38.0	51.6	65.2	78.7	92.3	105.9		
				kW	5.9	6.1	6.3	6.5	6.6	6.8	7.0	7.2		

XP078-150 (Continued)

Size (ton)	Model	Air over evaporator coil		Capacity ¹ and kW	Outdoor temperature (°F @ 72% RH)							
		CFM	DB (°F)		-10	0	10	20	30	40	50	60
120 (10)	XP	3000	55	MBH	15.2	27.8	40.5	53.1	65.7	78.3	91.0	103.6
				kW	5.0	5.1	5.3	5.5	5.7	5.8	6.0	6.2
			70	MBH	10.1	22.8	35.4	48.0	60.7	73.3	85.9	98.5
				kW	6.1	6.3	6.5	6.6	6.8	7.0	7.2	7.3
			80	MBH	6.3	19.0	31.6	44.2	56.8	69.5	82.1	94.7
				kW	7.0	7.2	7.4	7.5	7.7	7.9	8.1	8.2
		4000	55	MBH	34.9	47.6	60.2	72.8	85.4	98.1	110.7	123.3
				kW	4.7	4.9	5.1	5.3	5.4	5.6	5.8	6.0
			70	MBH	29.9	42.5	55.2	67.8	80.4	93.0	105.7	118.3
				kW	5.9	6.1	6.2	6.4	6.6	6.8	6.9	7.1
			80	MBH	26.1	38.7	51.3	64.0	76.6	89.2	101.8	114.5
				kW	6.8	7.0	7.1	7.3	7.5	7.7	7.8	8.0
		5000	55	MBH	35.7	48.3	60.9	73.5	86.2	98.8	111.4	124.0
				kW	4.5	4.7	4.8	5.0	5.2	5.4	5.5	5.7
			70	MBH	30.6	43.2	55.9	68.5	81.1	93.7	106.4	119.0
				kW	5.6	5.8	6.0	6.1	6.3	6.5	6.7	6.9
			80	MBH	26.8	39.4	52.0	64.7	77.3	89.9	102.6	115.2
				kW	6.5	6.7	6.9	7.0	7.2	7.4	7.6	7.8
150 (12.5)	XP	3750	55	MBH	31.4	50.4	69.4	88.5	107.5	126.5	145.6	164.6
				kW	6.8	7.2	7.7	8.2	8.6	9.1	9.6	10.0
			70	MBH	25.0	44.0	63.1	82.1	101.1	120.2	139.2	158.2
				kW	8.3	8.7	9.2	9.7	10.1	10.6	11.1	11.5
			80	MBH	21.9	40.9	59.9	79.0	98.0	117.0	136.0	155.1
				kW	9.4	9.9	10.4	10.8	11.3	11.8	12.2	12.7
		5000	55	MBH	34.5	53.5	72.6	91.6	110.6	129.7	148.7	167.7
				kW	5.8	6.3	6.7	7.2	7.7	8.1	8.6	9.1
			70	MBH	28.2	47.3	66.3	85.3	104.4	123.4	142.4	161.5
				kW	7.3	7.8	8.3	8.7	9.2	9.7	10.1	10.6
			80	MBH	25.2	44.2	63.2	82.3	101.3	120.3	139.4	158.4
				kW	8.5	9.0	9.5	9.9	10.4	10.9	11.3	11.8
		6250	55	MBH	35.4	54.5	73.5	92.5	111.6	130.6	149.6	168.7
				kW	5.5	5.9	6.4	6.9	7.3	7.8	8.3	8.7
			70	MBH	29.1	48.1	67.1	86.2	105.2	124.2	143.3	162.3
				kW	7.0	7.4	7.9	8.4	8.8	9.3	9.8	10.2
			80	MBH	25.9	45.0	64.0	83.0	102.1	121.1	140.1	159.1
				kW	8.1	8.6	9.1	9.5	10.0	10.5	10.9	11.4

1. These capacities do not include the supply air blower motor heat. For net capacity, add motor heat, MBh = 3.415 x kW.

Airflow performance

XP078-150 side duct application

XP078 (6.5 ton) side duct

Air flow (cfm)	Available external static pressure - IWG ¹																			
	0.2		0.4		0.6		0.8		1.0		1.2		1.4		1.6		1.8		2.0	
	rpm	bhp	rpm	bhp	rpm	bhp	rpm	bhp	rpm	bhp	rpm	bhp	rpm	bhp	rpm	bhp	rpm	bhp	rpm	bhp
	FS ⁴				Standard 1.5 HP and Drive						Hi Static 2 HP and Drive									
1800	441	0.44	552	0.54	639	0.63	719	0.72	785	0.81	859	0.99	920	1.16	966	1.25	1018	1.35	1066	1.43
2000	470	0.48	571	0.59	654	0.69	730	0.79	795	0.89	870	1.09	932	1.25	978	1.35	1030	1.44	1078	1.53
2200	500	0.54	591	0.66	669	0.76	743	0.87	806	0.97	882	1.18	944	1.35	990	1.44	1042	1.54	1090	1.62
2400	529	0.60	612	0.73	686	0.85	756	0.96	819	1.07	894	1.29	956	1.45	1002	1.55	1054	1.64	1102	1.73
2600	558	0.68	635	0.82	705	0.94	771	1.05	832	1.17	906	1.40	968	1.56	1014	1.66	1066	1.75	1114	1.84
2800	587	0.78	658	0.92	725	1.04	788	1.16	847	1.29	918	1.51	980	1.68	1026	1.77	1078	1.87	1126	1.95
3000	616	0.88	683	1.02	746	1.15	806	1.28	863	1.41	931	1.63	992	1.80	1038	1.89	1090	1.99	1138	2.07
3200	645	1.00	710	1.14	768	1.27	825	1.41	879	1.55	943	1.76	1005	1.92	1051	2.02	1103	2.12	1151	2.20
3400	674	1.14	737	1.27	792	1.40	846	1.55	897	1.70	956	1.89	1018	2.06	1064	2.15	1116	2.25	-	-
	FS ⁴																			

1. Blower performance includes gas heat exchangers and 2 in. filters. See the *Static resistance* table for additional applications.
2. See the *Selecting rpm* table to determine desired motor sheave setting and to determine the maximum continuous bhp.
3. kW = BHP x .932.
4. Field Supplied Drive.

XP090 (7.5 ton) side duct

Air flow (cfm)	Available external static pressure - IWG ¹																			
	0.2		0.4		0.6		0.8		1.0		1.2		1.4		1.6		1.8		2.0	
	rpm	bhp	rpm	bhp	rpm	bhp	rpm	bhp	rpm	bhp	rpm	bhp	rpm	bhp	rpm	bhp	rpm	bhp	rpm	bhp
	FS ⁴				Standard 1.5 HP and Drive						Hi Static 3 HP and Drive									
2000	-	-	656	0.24	711	0.48	768	0.73	826	0.96	886	1.19	945	1.41	1003	1.61	1058	1.79	1110	1.95
2200	619	0.07	670	0.32	724	0.57	781	0.81	840	1.04	899	1.27	959	1.49	1016	1.69	1072	1.87	1124	2.04
2400	631	0.16	682	0.41	736	0.66	793	0.90	852	1.14	911	1.36	970	1.58	1028	1.78	1084	1.97	1136	2.13
2600	642	0.27	692	0.52	747	0.76	804	1.01	862	1.24	922	1.47	981	1.69	1039	1.89	1094	2.07	1146	2.24
2800	652	0.39	703	0.64	757	0.88	814	1.13	873	1.36	932	1.59	992	1.81	1049	2.01	1105	2.19	1157	2.36
3000	663	0.53	714	0.77	768	1.02	825	1.26	884	1.50	943	1.73	1003	1.94	1060	2.14	1116	2.33	1168	2.49
3200	675	0.68	726	0.92	780	1.17	837	1.41	896	1.65	955	1.88	1014	2.09	1072	2.29	1128	2.48	1180	2.64
3400	688	0.84	739	1.09	793	1.34	850	1.58	909	1.82	968	2.04	1027	2.26	1085	2.46	1141	2.65	1193	2.81
3600	703	1.03	753	1.28	807	1.52	864	1.76	923	2.00	983	2.23	1042	2.44	1100	2.64	1155	2.83	-	-
3800	718	1.23	769	1.47	823	1.72	880	1.96	939	2.20	998	2.43	1058	2.64	1115	2.84	1171	3.03	-	-

1. Blower performance includes gas heat exchangers and 2 in. filters. See the *Static resistance* table for additional applications.
2. See the *Selecting rpm* table to determine desired motor sheave setting and to determine the maximum continuous bhp.
3. kW = bhp x 0.932.
4. Field Supplied Drive.

XP102 (8.5 ton) side duct

Air flow (cfm)	Available external static pressure - IWG ¹																			
	0.2		0.4		0.6		0.8		1.0		1.2		1.4		1.6		1.8		2.0	
	rpm	bhp	rpm	bhp	rpm	bhp	rpm	bhp	rpm	bhp	rpm	bhp	rpm	bhp	rpm	bhp	rpm	bhp	rpm	bhp
	2 HP and Field Supplied Drive				Standard 2 HP and Drive						Hi Static 3 HP and Drive									
2200	632	0.23	684	0.44	734	0.65	783	0.84	830	1.03	876	1.21	921	1.39	966	1.56	1009	1.74	1051	1.91
2400	639	0.32	691	0.53	741	0.74	790	0.93	837	1.12	883	1.30	928	1.48	972	1.65	1015	1.83	1058	2.00
2600	646	0.41	698	0.62	748	0.82	797	1.02	844	1.21	890	1.39	936	1.57	980	1.74	1023	1.92	1065	2.09
2800	654	0.50	706	0.71	756	0.92	805	1.11	852	1.30	898	1.48	943	1.66	987	1.83	1031	2.01	1073	2.18
3000	663	0.60	714	0.81	765	1.02	813	1.21	861	1.40	907	1.58	952	1.76	996	1.93	1039	2.11	1082	2.28
3200	673	0.71	724	0.93	774	1.13	823	1.32	871	1.51	917	1.69	962	1.87	1006	2.05	1049	2.22	1091	2.39
3400	684	0.84	735	1.05	785	1.25	834	1.45	882	1.63	928	1.82	973	2.00	1017	2.17	1060	2.34	1102	2.52
3600	696	0.98	747	1.19	798	1.39	846	1.59	894	1.78	940	1.96	985	2.14	1029	2.31	1072	2.48	1115	2.66
3800	709	1.14	761	1.35	811	1.55	860	1.75	907	1.93	953	2.12	999	2.29	1043	2.47	1086	2.64	1128	2.81
4000	724	1.31	776	1.52	826	1.72	874	1.92	922	2.11	968	2.29	1013	2.47	1057	2.64	1100	2.82	1143	2.99
4200	740	1.50	792	1.71	842	1.92	890	2.11	938	2.30	984	2.48	1029	2.66	1073	2.83	1116	3.01	1159	3.18
	3 HP and Field Supplied Drive																			

1. Blower performance includes 2 in. filters. See the *Static resistance* table for additional applications.
2. See the *Selecting rpm* table to determine desired motor sheave setting and to determine the maximum continuous BHP.
3. kW = BHP x 0.932.

XP120 (10 ton) side duct

Air flow (CFM)	Available external static pressure - IWG ¹																			
	0.2		0.4		0.6		0.8		1.0		1.2		1.4		1.6		1.8		2.0	
	rpm	bhp	rpm	bhp	rpm	bhp	rpm	bhp	rpm	bhp	rpm	bhp	rpm	bhp	rpm	bhp	rpm	bhp	rpm	bhp
	2 HP and Field Supplied Drive						Standard 2 HP and Drive						Hi Static 3 HP and Drive							
2600	646	0.41	698	0.62	748	0.82	797	1.02	844	1.21	890	1.39	936	1.57	980	1.74	1023	1.92	1065	2.09
2800	654	0.50	706	0.71	756	0.92	805	1.11	852	1.30	898	1.48	943	1.66	987	1.83	1031	2.01	1073	2.18
3000	663	0.60	714	0.81	765	1.02	813	1.21	861	1.40	907	1.58	952	1.76	996	1.93	1039	2.11	1082	2.28
3200	673	0.71	724	0.93	774	1.13	823	1.32	871	1.51	917	1.69	962	1.87	1006	2.05	1049	2.22	1091	2.39
3400	684	0.84	735	1.05	785	1.25	834	1.45	882	1.63	928	1.82	973	2.00	1017	2.17	1060	2.34	1102	2.52
3600	696	0.98	747	1.19	798	1.39	846	1.59	894	1.78	940	1.96	985	2.14	1029	2.31	1072	2.48	1115	2.66
3800	709	1.14	761	1.35	811	1.55	860	1.75	907	1.93	953	2.12	999	2.29	1043	2.47	1086	2.64	1128	2.81
4000	724	1.31	776	1.52	826	1.72	874	1.92	922	2.11	968	2.29	1013	2.47	1057	2.64	1100	2.82	1143	2.99
4200	740	1.50	792	1.71	842	1.92	890	2.11	938	2.30	984	2.48	1029	2.66	1073	2.83	1116	3.01	1159	3.18
4400	757	1.71	809	1.92	859	2.13	908	2.32	955	2.51	1001	2.69	1046	2.87	1091	3.04	1134	3.22	1176	3.39
4600	776	1.94	827	2.15	877	2.35	926	2.55	974	2.74	1020	2.92	1065	3.10	1109	3.27	1152	3.45	-	-
4800	795	2.19	847	2.40	897	2.60	946	2.79	993	2.98	1040	3.16	1085	3.34	-	-	-	-	-	-
5000	816	2.45	868	2.66	918	2.86	967	3.06	1014	3.25	1061	3.43	-	-	-	-	-	-	-	-
													3 HP and Field Supplied Drive							

1. Blower performance includes 2 in. filters. See the *Static resistance* table for additional applications.
2. See the *Selecting rpm* table to determine desired motor sheave setting and to determine the maximum continuous bhp.
3. kW = BHP x 0.932.

XP150 (12.5 ton) side duct

Air flow (CFM)	Available external static pressure - IWG ¹																			
	0.2		0.4		0.6		0.8		1.0		1.2		1.4		1.6		1.8		2.0	
	rpm	bhp	rpm	bhp	rpm	bhp	rpm	bhp	rpm	bhp	rpm	bhp	rpm	bhp	rpm	bhp	rpm	bhp	rpm	bhp
	3 HP and Field Supplied Drive						Standard 3 HP and Drive						Hi Static 5 HP and Drive							
3200	673	0.71	724	0.93	774	1.13	823	1.32	871	1.51	917	1.69	962	1.87	1006	2.05	1049	2.22	1091	2.39
3400	684	0.84	735	1.05	785	1.25	834	1.45	882	1.63	928	1.82	973	2.00	1017	2.17	1060	2.34	1102	2.52
3600	696	0.98	747	1.19	798	1.39	846	1.59	894	1.78	940	1.96	985	2.14	1029	2.31	1072	2.48	1115	2.66
3800	709	1.14	761	1.35	811	1.55	860	1.75	907	1.93	953	2.12	999	2.29	1043	2.47	1086	2.64	1128	2.81
4000	724	1.31	776	1.52	826	1.72	874	1.92	922	2.11	968	2.29	1013	2.47	1057	2.64	1100	2.82	1143	2.99
4200	740	1.50	792	1.71	842	1.92	890	2.11	938	2.30	984	2.48	1029	2.66	1073	2.83	1116	3.01	1159	3.18
4400	757	1.71	809	1.92	859	2.13	908	2.32	955	2.51	1001	2.69	1046	2.87	1091	3.04	1134	3.22	1176	3.39
4600	776	1.94	827	2.15	877	2.35	926	2.55	974	2.74	1020	2.92	1065	3.10	1109	3.27	1152	3.45	1194	3.62
4800	795	2.19	847	2.40	897	2.60	946	2.79	993	2.98	1040	3.16	1085	3.34	1129	3.52	1172	3.69	1214	3.86
5000	816	2.45	868	2.66	918	2.86	967	3.06	1014	3.25	1061	3.43	1106	3.61	1150	3.78	1193	3.95	1235	4.13
5200	839	2.73	890	2.94	940	3.14	989	3.34	1037	3.53	1083	3.71	1128	3.89	1172	4.06	1215	4.23	1257	4.41
5400	862	3.03	914	3.24	964	3.44	1012	3.64	1060	3.82	1106	4.01	1151	4.18	1195	4.36	1238	4.53	1281	4.70
5600	886	3.34	938	3.55	988	3.76	1037	3.95	1084	4.14	1131	4.32	1176	4.50	1220	4.67	1263	4.85	1305	5.02
5800	912	3.67	964	3.89	1014	4.09	1063	4.28	1110	4.47	1156	4.65	1201	4.83	1246	5.01	1289	5.18	1331	5.35
6000	939	4.02	990	4.23	1041	4.44	1089	4.63	1137	4.82	1183	5.00	1228	5.18	1272	5.35	1315	5.53	1358	5.70
6200	967	4.39	1018	4.60	1068	4.80	1117	4.99	1165	5.18	1211	5.36	1256	5.54	1300	5.72	-	-	-	-
													5 HP and Field Supplied Drive							

1. Blower performance includes 2 in. filters. See the *Static resistance* table for additional applications.
2. See the *Selecting rpm* table to determine desired motor sheave setting and to determine the maximum continuous bhp.
3. kW = BHP x 0.932.

XP078-150 bottom duct application

XP078 (6.5 ton) bottom duct

Air flow (cfm)	Available external static pressure - IWG ¹																			
	0.2		0.4		0.6		0.8		1.0		1.2		1.4		1.6		1.8		2.0	
	rpm	bhp	rpm	bhp	rpm	bhp	rpm	bhp	rpm	bhp	rpm	bhp	rpm	bhp	rpm	bhp	rpm	bhp	rpm	bhp
	FS ⁴				Standard 1.5 HP and Drive				Hi Static 2 HP and Drive											
1800	445	0.63	559	0.66	648	0.69	730	0.72	799	0.75	875	0.89	937	0.99	984	1.05	1038	1.08	1086	1.11
2000	486	0.71	589	0.76	674	0.79	753	0.83	820	0.87	898	1.02	960	1.13	1007	1.18	1061	1.21	1109	1.25
2200	530	0.84	624	0.90	705	0.94	781	0.99	846	1.03	924	1.19	988	1.31	1034	1.35	1088	1.39	1137	1.42
2400	567	0.91	653	0.98	729	1.04	801	1.09	867	1.14	944	1.31	1007	1.41	1055	1.47	1108	1.50	1156	1.54
2600	605	1.02	685	1.10	758	1.16	826	1.21	889	1.27	965	1.45	1028	1.55	1075	1.60	1128	1.63	1178	1.67
2800	645	1.16	719	1.24	788	1.29	854	1.36	915	1.43	988	1.60	1051	1.71	1099	1.75	1151	1.80	1201	1.83
3000	686	1.31	757	1.39	822	1.46	885	1.53	943	1.60	1013	1.77	1076	1.88	1123	1.93	1176	1.97	1225	2.00
3200	729	1.49	797	1.57	858	1.64	917	1.73	972	1.81	1038	1.96	1102	2.07	1149	2.11	1203	2.16	1252	2.19
3400	772	1.70	839	1.77	897	1.84	953	1.93	1005	2.03	1066	2.16	1130	2.27	1177	2.31	1230	2.36		
	FS ⁴																			

1. Blower performance includes gas heat exchangers and 2 in. filters. See the *Static resistance* table for additional applications.
2. See the *Selecting rpm* table to determine desired motor sheave setting and to determine the maximum continuous bhp.
3. kW = bhp x .932.
4. Field supplied drive.

XP090 (7.5 ton) bottom duct

Air flow (cfm)	Available external static pressure - IWG ¹																			
	0.2		0.4		0.6		0.8		1.0		1.2		1.4		1.6		1.8		2.0	
	rpm	bhp	rpm	bhp	rpm	bhp	rpm	bhp	rpm	bhp	rpm	bhp	rpm	bhp	rpm	bhp	rpm	bhp	rpm	bhp
	FS ⁴				Standard 1.5 HP and Drive				Hi Static 3 HP and Drive											
2000	644	0.11	698	0.38	755	0.62	814	0.85	874	1.06	933	1.26	990	1.46	1043	1.66	1090	1.87	1131	2.09
2200	666	0.26	720	0.53	777	0.77	836	1.00	896	1.21	956	1.41	1012	1.61	1065	1.81	1113	2.02	1153	2.24
2400	689	0.42	743	0.69	800	0.93	859	1.16	919	1.37	978	1.57	1035	1.77	1088	1.97	1135	2.18	1176	2.40
2600	712	0.60	766	0.87	823	1.11	882	1.34	942	1.55	1002	1.75	1058	1.95	1111	2.15	1159	2.36	1199	2.58
2800	736	0.80	790	1.06	847	1.31	906	1.53	967	1.74	1026	1.94	1082	2.14	1135	2.34	1183	2.55	1223	2.78
3000	761	1.00	815	1.27	872	1.52	931	1.74	991	1.95	1051	2.15	1107	2.35	1160	2.55	1208	2.76	1248	2.98
3200	787	1.22	840	1.49	898	1.74	957	1.96	1017	2.17	1076	2.37	1133	2.57	1186	2.77	1233	2.98	1274	3.20
3400	813	1.46	867	1.73	924	1.97	984	2.19	1044	2.40	1103	2.61	1160	2.80	1212	3.01	1260	3.21	-	-
3600	841	1.70	894	1.97	952	2.21	1011	2.44	1071	2.65	1130	2.85	1187	3.05	-	-	-	-	-	-
3800	869	1.96	923	2.22	980	2.47	1039	2.69	1099	2.90	1158	3.10	1215	3.30	-	-	-	-	-	-
	3 HP and Field Supplied Drive																			

1. Blower performance includes gas heat exchangers and 2 in. filters. See the *Static resistance* table for additional applications.
2. See the *Selecting rpm* table to determine desired motor sheave setting and to determine the maximum continuous bhp.
3. kW = bhp x 0.932.
4. Field supplied drive.

XP102 (8.5 ton) bottom duct

Air flow (cfm)	Available external static pressure - IWG ¹																			
	0.2		0.4		0.6		0.8		1.0		1.2		1.4		1.6		1.8		2.0	
	rpm	bhp	rpm	bhp	rpm	bhp	rpm	bhp	rpm	bhp	rpm	bhp	rpm	bhp	rpm	bhp	rpm	bhp	rpm	bhp
	2 HP and Field Supplied Drive				Standard 2 HP and Drive				Hi Static 3 HP and Drive											
2200	662	0.53	717	0.68	770	0.83	821	0.96	870	1.09	918	1.22	965	1.35	1010	1.47	1055	1.59	1098	1.71
2400	677	0.63	732	0.78	784	0.93	835	1.06	885	1.19	933	1.32	979	1.44	1025	1.57	1069	1.69	1112	1.81
2600	693	0.75	748	0.90	801	1.04	852	1.18	901	1.31	949	1.44	996	1.56	1041	1.68	1085	1.80	1129	1.92
2800	712	0.88	767	1.03	819	1.17	871	1.31	920	1.44	968	1.57	1014	1.69	1060	1.81	1104	1.94	1148	2.06
3000	733	1.03	788	1.18	841	1.33	892	1.46	941	1.59	989	1.72	1036	1.84	1081	1.97	1125	2.09	1169	2.21
3200	757	1.20	811	1.36	864	1.50	915	1.64	964	1.77	1012	1.89	1059	2.02	1104	2.14	1149	2.26	1192	2.38
3400	782	1.40	837	1.55	890	1.69	941	1.83	990	1.96	1038	2.09	1085	2.21	1130	2.33	1174	2.45	1218	2.58
3600	810	1.61	865	1.76	918	1.91	969	2.04	1018	2.18	1066	2.30	1113	2.43	1158	2.55	1203	2.67	1246	2.79
3800	841	1.85	896	2.00	948	2.14	999	2.28	1049	2.41	1097	2.54	1143	2.66	1189	2.78	1233	2.91	1276	3.03
4000	874	2.11	928	2.26	981	2.40	1032	2.54	1082	2.67	1130	2.80	1176	2.92	1222	3.04	1266	3.16	1309	3.28
4200	909	2.38	963	2.53	1016	2.68	1067	2.81	1117	2.95	1164	3.07	1211	3.20	1256	3.32	1301	3.44	-	-
	3 HP and Field Supplied Drive																			

1. Blower performance includes 2 in. filters. See the *Static resistance* table for additional applications.
2. See the *Selecting rpm* table to determine desired motor sheave setting and to determine the maximum continuous bhp.
3. kW = BHP x 0.932.

XP120 (10 ton) bottom duct

Air flow (cfm)	Available external static pressure - IWG ¹																			
	0.2		0.4		0.6		0.8		1.0		1.2		1.4		1.6		1.8		2.0	
	rpm	bhp	rpm	bhp	rpm	bhp	rpm	bhp	rpm	bhp	rpm	bhp	rpm	bhp	rpm	bhp	rpm	bhp	rpm	bhp
	2 HP and Field Supplied Drive				Standard 2 HP and Drive						Hi Static 3 HP and Drive									
2600	693	0.75	748	0.90	801	1.04	852	1.18	901	1.31	949	1.44	996	1.56	1041	1.68	1085	1.80	1129	1.92
2800	712	0.88	767	1.03	819	1.17	871	1.31	920	1.44	968	1.57	1014	1.69	1060	1.81	1104	1.94	1148	2.06
3000	733	1.03	788	1.18	841	1.33	892	1.46	941	1.59	989	1.72	1036	1.84	1081	1.97	1125	2.09	1169	2.21
3200	757	1.20	811	1.36	864	1.50	915	1.64	964	1.77	1012	1.89	1059	2.02	1104	2.14	1149	2.26	1192	2.38
3400	782	1.40	837	1.55	890	1.69	941	1.83	990	1.96	1038	2.09	1085	2.21	1130	2.33	1174	2.45	1218	2.58
3600	810	1.61	865	1.76	918	1.91	969	2.04	1018	2.18	1066	2.30	1113	2.43	1158	2.55	1203	2.67	1246	2.79
3800	841	1.85	896	2.00	948	2.14	999	2.28	1049	2.41	1097	2.54	1143	2.66	1189	2.78	1233	2.91	1276	3.03
4000	874	2.11	928	2.26	981	2.40	1032	2.54	1082	2.67	1130	2.80	1176	2.92	1222	3.04	1266	3.16	1309	3.28
4200	909	2.38	963	2.53	1016	2.68	1067	2.81	1117	2.95	1164	3.07	1211	3.20	1256	3.32	1301	3.44	-	-
4400	946	2.68	1000	2.83	1053	2.98	1104	3.11	1154	3.24	1202	3.37	-	-	-	-	-	-	-	-
4600	985	3.00	1040	3.15	1092	3.29	1143	3.43	-	-	-	-	-	-	-	-	-	-	-	-
4800	1026	3.33	-	-	-	-	-	-	-	-	-	-	-	-	-	-	-	-	-	-

3 HP and Field Supplied Drive

1. Blower performance includes 2 in. filters. See *Static resistance* table for additional applications.
2. See the *Selecting rpm* table to determine desired motor sheave setting and to determine the maximum continuous bhp.
3. kW = BHP x 0.932.

XP150 (12.5 ton) bottom duct

Air flow (cfm)	Available external static pressure - IWG ¹																			
	0.2		0.4		0.6		0.8		1.0		1.2		1.4		1.6		1.8		2.0	
	rpm	bhp	rpm	bhp	rpm	bhp	rpm	bhp	rpm	bhp	rpm	bhp	rpm	bhp	rpm	bhp	rpm	bhp	rpm	bhp
	3 HP and Field Supplied Drive				Standard 3 HP and Drive						Hi Static 5 HP and Drive									
3200	757	1.20	811	1.36	864	1.50	915	1.64	964	1.77	1012	1.89	1059	2.02	1104	2.14	1149	2.26	1192	2.38
3400	782	1.40	837	1.55	890	1.69	941	1.83	990	1.96	1038	2.09	1085	2.21	1130	2.33	1174	2.45	1218	2.58
3600	810	1.61	865	1.76	918	1.91	969	2.04	1018	2.18	1066	2.30	1113	2.43	1158	2.55	1203	2.67	1246	2.79
3800	841	1.85	896	2.00	948	2.14	999	2.28	1049	2.41	1097	2.54	1143	2.66	1189	2.78	1233	2.91	1276	3.03
4000	874	2.11	928	2.26	981	2.40	1032	2.54	1082	2.67	1130	2.80	1176	2.92	1222	3.04	1266	3.16	1309	3.28
4200	909	2.38	963	2.53	1016	2.68	1067	2.81	1117	2.95	1164	3.07	1211	3.20	1256	3.32	1301	3.44	1344	3.56
4400	946	2.68	1000	2.83	1053	2.98	1104	3.11	1154	3.24	1202	3.37	1248	3.49	1294	3.62	1338	3.74	1381	3.86
4600	985	3.00	1040	3.15	1092	3.29	1143	3.43	1193	3.56	1241	3.69	1287	3.81	1333	3.93	1377	4.05	1420	4.18
4800	1026	3.33	1081	3.48	1133	3.63	1184	3.76	1234	3.90	1282	4.02	1328	4.15	1374	4.27	1418	4.39	1461	4.51
5000	1069	3.69	1124	3.84	1177	3.98	1228	4.12	1277	4.25	1325	4.38	1372	4.50	1417	4.62	1461	4.74	1505	4.87
5200	1114	4.06	1169	4.21	1222	4.35	1273	4.49	1322	4.62	1370	4.75	1417	4.87	1462	5.00	1506	5.12	1550	5.24
5400	1161	4.45	1216	4.60	1268	4.74	1319	4.88	1369	5.01	1417	5.14	1463	5.26	1509	5.38	1553	5.51	1596	5.63
5600	1210	4.86	1264	5.01	1317	5.15	1368	5.29	1418	5.42	1465	5.55	1512	5.67	-	-	-	-	-	-
5800	1260	5.28	1315	5.43	1367	5.57	1418	5.71	-	-	-	-	-	-	-	-	-	-	-	-

5 HP and Field Supplied Drive

1. Blower performance includes 2 in. filters. See the *Static resistance* table for additional applications.
2. See the *Selecting rpm* table to determine desired motor sheave setting and to determine the maximum continuous bhp.
3. kW = BHP x 0.932.

Selecting rpm

Size (ton)	Model	HP	Max BHP	Motor sheave	Blower sheave	6 turns open	5 turns open	4 turns open	3 turns open	2 turns open	1 turn open	Fully closed
078 (6.5)	XP	1.5	1.73	VL40	AK84	NA	576	618	661	702	748	792
		2.0	2.30	VL44	AK71	NA	790	843	887	936	989	1041
090 (7.5)	XP	1.5	1.73	1VL40	AK69	N/A	690	743	796	849	902	955
		3	3.45	1VM50	AK69	N/A	955	1008	1062	1115	1168	1221
102 (8.5)	XP	2	2.30	1VP50	AK89	N/A	735	775	815	851	889	930
		3	3.45	1VP50	AK74	N/A	880	928	972	1016	1067	1110
120 (10)	XP	2	2.30	1VM50	AK84	N/A	785	821	858	901	940	980
		3	3.45	1VM50	AK74	N/A	880	928	972	1016	1067	1110
150 (12.5)	XP	3	3.45	1VM50	AK74	N/A	880	928	972	1016	1067	1110
		5	5.75	1VP56	BK77	1052	1095	1136	1175	1216	1272	N/A

Additional static resistance

Size (ton)	Model	CFM	Economizer ^{1 2}	4 in. filter ¹	Electric Heat kW ¹				
					9	18	24	36	54
078 (6.5) 090 (7.5) 102 (8.5) 120 (10) 150 (12.5)	XP	1900	0.02	0.12	0.05	0.06	0.07	0.08	0.10
		2100	0.02	0.13	0.06	0.07	0.08	0.09	0.11
		2300	0.04	0.14	0.07	0.08	0.09	0.10	0.13
		2500	0.11	0.16	0.08	0.09	0.10	0.11	0.14
		2700	0.18	0.17	0.09	0.10	0.12	0.13	0.16
		2900	0.25	0.19	0.10	0.11	0.13	0.14	0.18
		3100	0.31	0.20	0.12	0.13	0.15	0.16	0.20
		3300	0.37	0.22	0.13	0.14	0.17	0.18	0.22
		3500	0.43	0.26	0.15	0.16	0.19	0.20	0.24
		3700	0.49	0.27	0.17	0.18	0.21	0.22	0.26
		3900	0.54	0.29	0.19	0.20	0.23	0.24	0.28
		4100	0.58	0.32	0.21	0.22	0.25	0.26	0.31
		4300	0.65	0.35	0.23	0.24	0.28	0.29	0.34
		4500	0.69	0.38	0.25	0.26	0.30	0.31	0.37
		4700	0.74	0.41	0.28	0.29	0.33	0.34	0.40
		4900	0.78	0.44	0.30	0.31	0.35	0.37	0.43
		5100	0.82	0.47	0.33	0.34	0.38	0.40	0.46
		5300	0.86	0.51	0.35	0.37	0.41	0.43	0.49
		5500	0.89	0.55	0.38	0.40	0.44	0.46	0.53
		5700	0.93	0.58	0.41	0.43	0.47	0.49	0.56
5900	0.96	0.62	0.44	0.46	0.50	0.53	0.59		
6100	0.98	0.67	0.47	0.49	0.53	0.56	0.62		
6300	1.01	0.71	0.50	0.53	0.56	0.59	0.65		

1. Deduct these values from the available external static pressure shown in the respective *Blower performance* tables.
2. The pressure drop through the economizer is greater for 100% outdoor air than for 100% return air. If the resistance of the return air duct is less than 0.25 IWG, the unit will deliver less cfm during full economizer operation.

Drive selection

1. Determine side or bottom supply duct Application.
2. Determine desired airflow.
3. Calculate or measure the amount of external static pressure.
4. Using the operating point determined from steps 1, 2 and 3, locate this point on the appropriate supply air blower performance table. (Linear interpolation may be necessary.)
5. Noting the RPM and BHP from step 4, locate the appropriate motor and, or drive on the RPM selection table.
6. Review the BHP compared to the motor options available. Select the appropriate motor and, or drive.
7. Review the RPM range for the motor options available. Select the appropriate drive if multiple drives are available for the chosen motor.
8. Determine turns open to obtain the desired operation point.

Example

1. 2600 CFM
2. 1.6 iwg
3. Using the supply air blower performance table below, the following data point was located: 1268 RPM and 1.95 BHP.
4. Using the RPM selection table below, Size X and Model Y is found.
5. 1.95 BHP exceeds the maximum continuous BHP rating of the 1.5 HP motor. The 2 HP motor is required.
6. 1268 RPM is within the range of the 2 HP drives.
7. Using the 2 HP motor and drive, .5 turns open will achieve 1268 RPM.

Airflow performance**Example supply air blower performance**

Air flow (cfm)	Available external static pressure - IWG																			
	0.2		0.4		0.6		0.8		1.0		1.2		1.4		1.6		1.8		2.0	
	rpm	bhp	rpm	bhp	rpm	bhp	rpm	bhp	rpm	bhp	rpm	bhp	rpm	bhp	rpm	bhp	rpm	bhp	rpm	bhp
	1.5 HP and Field Supplied Drive						Standard 1.5 HP and Drive						Alternate 2 HP and Drive							
2200	804	0.50	866	0.71	925	0.90	982	1.06	1038	1.21	1092	1.35	1147	1.48	1203	1.61	1259	1.73	1317	1.87
2400	835	0.66	897	0.87	956	1.06	1013	1.22	1069	1.37	1124	1.51	1178	1.64	1234	1.77	1290	1.90	1348	2.03
2600	869	0.84	931	1.05	990	1.24	1047	1.40	1103	1.55	1158	1.69	1212	1.82	1268	1.95	1324	2.07	1382	2.21
2800	906	1.03	968	1.25	1027	1.43	1084	1.60	1139	1.75	1194	1.89	1249	2.02	1304	2.14	1361	2.27	-	-

Table X: RPM Selection

Size (ton)	Model	HP	Max BHP	Motor sheave	Blower sheave	6 turns open	5 turns open	4 turns open	3 turns open	2 turns open	1 turn open	Fully closed
X	Y	1.5	1.73	1VM50	AK74	N/A	897	945	991	1035	1079	1126
		2	2.30	1VM50	AK64	N/A	1039	1094	1150	1207	1256	1308

Altitude/temperature correction factors

Air temperature (°F)	Altitude (ft)										
	0	1000	2000	3000	4000	5000	6000	7000	8000	9000	10000
40	1.060	1.022	0.986	0.950	0.916	0.882	0.849	0.818	0.788	0.758	0.729
50	1.039	1.002	0.966	0.931	0.898	0.864	0.832	0.802	0.772	0.743	0.715
60	1.019	0.982	0.948	0.913	0.880	0.848	0.816	0.787	0.757	0.729	0.701
70	1.000	0.964	0.930	0.896	0.864	0.832	0.801	0.772	0.743	0.715	0.688
80	0.982	0.947	0.913	0.880	0.848	0.817	0.787	0.758	0.730	0.702	0.676
90	0.964	0.929	0.897	0.864	0.833	0.802	0.772	0.744	0.716	0.689	0.663
100	0.946	0.912	0.880	0.848	0.817	0.787	0.758	0.730	0.703	0.676	0.651

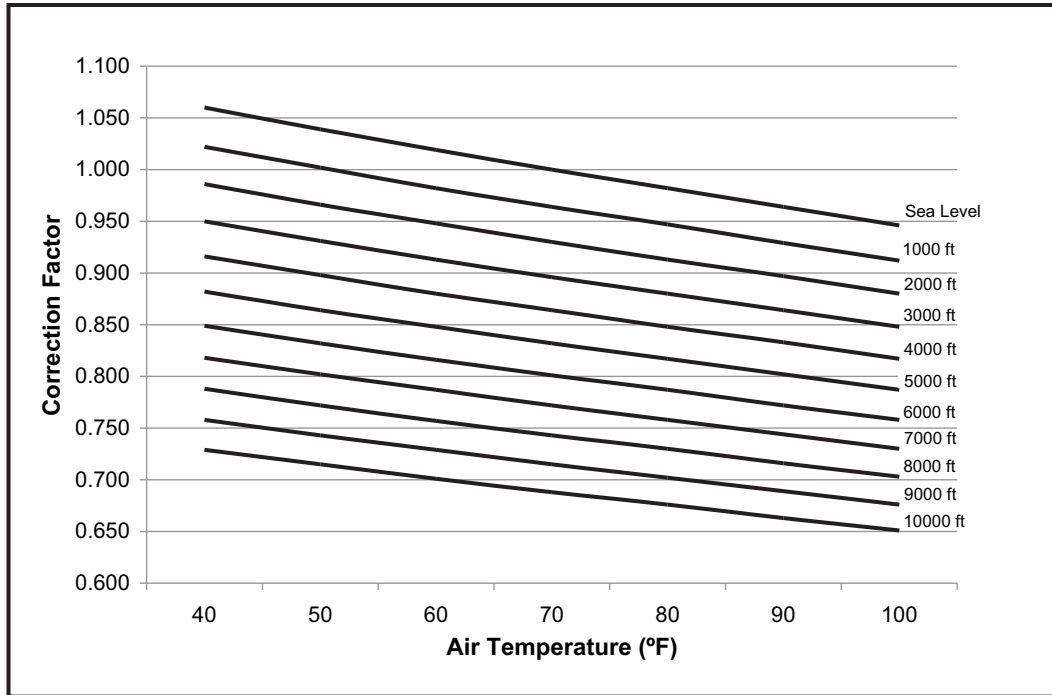

Electric heat minimum supply air

Size (ton)	Model	Voltage	Minimum supply air (CFM)				
			Heater kW				
			9	18	24	36	54
078 (6.5)	XP	208/230-3-60	1950	1950	1950	1950	—
		460-3-60	1950	1950	1950	1950	—
		600-3-60	1950	1950	1950	1950	—
090 (7.5)	XP	208/230-3-60	2250	2250	2250	2250	—
		460-3-60	2250	2250	2250	2250	—
		600-3-60	2250	2250	2250	2250	—
102 (8.5)	XP	208/230-3-60	2550	2550	2550	2550	—
		460-3-60	2550	2550	2550	2550	—
		600-3-60	2550	2550	2550	2550	—
120 (10)	XP	208/230-3-60	—	3000	3000	3000	3500
		460-3-60	—	3000	3000	3000	3000
		600-3-60	—	3000	3000	3000	3500
150 (12.5)	XP	208/230-3-60	—	3750	3750	3750	4000
		460-3-60	—	3750	3750	3750	3750
		600-3-60	—	3750	3750	3750	3750

Indoor blower specifications

Size (ton)	Model	Motor					Motor sheave			Blower sheave			Belt
		HP	RPM	Eff.	SF	Frame	Datum diameter (in.)	Bore (in.)	Model	Datum diameter (in.)	Bore (in.)	Model	
078 (6.5)	XP	1-1/2	1725	0.8	1.15	56	2.4 - 3.4	7/8	VL40	8.1	1	AK84	A54
		2	1725	0.8	1.15	56	2.8 - 3.8	7/8	VL44	6.7	1	AK71	A52
090 (7.5)	XP	1-1/2	1725	0.8	1.15	56	2.6 - 3.6	7/8	1VL40	6.5	1	AK69	A52
		3	1725	0.8	1.15	56	3.6 - 4.6	7/8	1VM50	6.5	1	AK69	A54
102 (8.5)	XP	2	1725	0.8	1.15	56	3.4 - 4.4	7/8	1VP50	8.5	1	AK89	A56
		3	1725	0.8	1.15	56	3.4 - 4.4	7/8	1VP50	7.0	1	AK74	A54
120 (10)	XP	2	1725	0.8	1.15	56	3.4 - 4.4	7/8	1VM50	8.0	1	AK84	A56
		3	1725	0.8	1.15	56	3.4 - 4.4	7/8	1VM50	7.0	1	AK74	A54
150 (12.5)	XP	3	1725	0.8	1.15	56	3.4 - 4.4	7/8	1VM50	7.0	1	AK74	A54
		5	1725	0.87	1.15	184T	4.3 - 5.3	1-1/8	1VP56	6.7	1	BK77	BX56

Power exhaust specifications

Model	Voltage	Motor			Unit (per circuit)			Fuse size	CFM @ 0.1 ESP
		HP	RPM ¹	QTY	LRA	FLA	MCA		
2PE04704706	208/230-1-60	3/4	1075	1	24.9	5	6.3	10	4800
2PE04704746	460-1-60	3/4	1075	1	N/A	2.2	2.8	5	4800
2PE04704758	575-1-60	3/4	1050	1	N/A	1.5	1.9	4	4800

1. Motors are multi-tapped and factory wired for high speed.

Electric heat multipliers

Voltage		kW Capacity Multipliers ¹
Nominal	Applied	
240	208	0.75
	230	0.92
480	460	0.92
	575	0.92

1. Electric heaters are rated at nominal voltage. Use this table to determine the electric heat capacity for heaters applied at lower voltages.

Sound performance

Indoor sound power levels

Size (ton)	Model	CFM	ESP (IWG)	Blower		Sound power, dB (10 ⁻¹²) Watts								
						RPM	BHP	Sound rating ¹ dB (A)	Octave band centerline frequency (Hz)					
				63	125				250	500	1000	2000	4000	8000
078 (6.5)	XP	2600	0.6	812	1.14	74	71	73	73	71	69	65	65	60
090 (7.5)	XP	3000	0.6	854	1.47	77	74	76	76	74	72	68	68	63
102 (8.5)	XP	3400	0.6	872	1.65	80	77	79	79	77	75	71	71	66
120 (10)	XP	4000	0.6	959	2.29	83	80	82	82	80	78	74	74	69
150 (12.5)	XP	5000	0.6	1132	3.74	87	84	86	86	84	82	78	78	73

1. These values have been accessed using a model of sound propagation from a point source into the hemispheric/free field. The dBA values provided are to be used for reference only. Calculation of dBA values cover matters of system design and the fan manufacture has no way of knowing the details of each system. This constitutes an exception to any specification or guarantee requiring a dBA value of sound data in any other form than sound power level ratings.

Outdoor sound power levels

Size (ton)	Model	Sound rating ¹ dB (A)	Octave band centerline frequency (Hz)						
			125	250	500	1000	2000	4000	8000
078 (6.5)	XP	83	88.0	82.5	81.5	78.0	73.0	69.0	62.0
090 (7.5)	XP	83	89.5	83.5	82.0	78.0	72.5	68.0	60.5
102 (8.5)	XP	83	89.0	84.5	81.5	78.0	72.5	68.5	70.5
120 (10)	XP	83	89.5	83.5	81.0	78.0	72.0	68.5	70.5
150 (12.5)	XP	84	90.0	84.5	81.5	77.5	72.0	68.5	61.5

1. Rated in accordance with AHRI 270 standard.

Electrical data

XP078-150 standard motor - without powered convenience outlet

Size (ton)	Voltage	Compressors (each)			OD fan motors (each)	Supply blower motor	Pwr Exh motor	Pwr Conv outlet	Electric heat option				MCA ¹ (Amps)	MCA ¹ w/Pwr Exh (Amps)	Max fuse ² / breaker ³ size (Amps)	Max fuse ¹ / breaker ³ size w/Pwr Exh (Amps)
		RLA	LRA	MCC	FLA	FLA	FLA	FLA	Model	kW	Stages	Amps				
078 (6)	208-3-60	13.5	88	21	1.65	5.2	5.5	—	None	—	—	—	38.9	44.4	50	50
									E09	6.8	1	18.9	62.5	68	70	70
									E18	13.5	2	37.5	85.8	91.3	90	100
									E24	18	2	50	101.4	106.9	110	110
									E36	25.5	2	70.8	127.4	132.9	150	150
	230-3-60	13.5	88	21	1.65	5.2	5.5	—	None	—	—	—	38.9	44.4	50	50
									E09	9	1	21.7	66	71.5	70	80
									E18	18	2	43.3	93	98.5	100	100
									E24	24	2	57.7	111	116.5	125	125
									E36	34	2	81.8	141.2	146.7	150	150
	460-3-60	6	44	9	1.1	2.6	2.2	—	None	—	—	—	18.3	20.5	20	25
									E09	9	1	10.8	31.8	34	35	35
									E18	18	2	21.7	45.4	47.6	50	50
									E24	24	2	28.9	54.4	56.6	60	60
									E36	34	2	40.9	69.4	71.6	70	80
	575-3-60	4.9	34	8	0.65	2	1.8	—	None	—	—	—	14.3	16.1	15	20
									E09	9	1	8.7	25.2	27	30	30
									E18	18	2	17.3	35.9	37.7	40	40
									E24	24	2	23.1	43.2	45	45	45
									E36	34	2	32.7	55.2	57	60	60
090 (7.5)	208-3-60	13.7	83.1	21	1.65	5.2	5.5	—	None	—	—	—	39.3	44.8	50	50
									E09	6.8	1	18.9	62.9	68.4	70	70
									E18	13.5	2	37.5	86.2	91.7	90	100
									E24	18	2	50	101.8	107.3	110	110
									E36	25.5	2	70.8	127.8	133.3	150	150
	230-3-60	13.7	83.1	21	1.65	5.2	5.5	—	None	—	—	—	39.3	44.8	50	50
									E09	9	1	21.7	66.4	71.9	70	80
									E18	18	2	43.3	93.4	98.9	100	100
									E24	24	2	57.7	111.4	116.9	125	125
									E36	34	2	81.8	141.6	147.1	150	150
	460-3-60	6.2	41	10	1.1	2.6	2.2	—	None	—	—	—	18.8	21	25	25
									E09	9	1	10.8	32.3	34.5	35	35
									E18	18	2	21.7	45.9	48.1	50	50
									E24	24	2	28.9	54.9	57.1	60	60
									E36	34	2	40.9	69.9	72.1	70	80
	575-3-60	4.8	33	8	0.65	2	1.8	—	None	—	—	—	14.1	15.9	15	20
									E09	9	1	8.7	25	26.8	25	30
									E18	18	2	17.3	35.7	37.5	40	40
									E24	24	2	23.1	43	44.8	45	45
									E36	34	2	32.7	55	56.8	60	60

XP078-150 standard motor - without powered convenience outlet (Continued)

Size (ton)	Voltage	Compressors (each)			OD fan motors (each)	Supply blower motor	Pwr Exh motor	Pwr Conv outlet	Electric heat option				MCA ¹ (Amps)	MCA ¹ w/Pwr Exh (Amps)	Max fuse ² / breaker ³ size (Amps)	Max fuse ¹ / breaker ³ size w/ Pwr Exh (Amps)
		RLA	LRA	MCC	FLA	FLA	FLA	FLA	Model	kW	Stages	Amps				
102 (8.5)	208-3-60	14.5	98	23	1.65	6.8	5.5	—	None	—	—	—	42.7	48.2	50	60
									E09	6.8	1	18.9	66.3	71.8	70	80
									E18	13.5	2	37.5	89.6	95.1	90	100
									E24	18	2	50	105.2	110.7	110	125
									E36	25.5	2	70.8	131.2	136.7	150	150
	230-3-60	14.5	98	23	1.65	6.8	5.5	—	None	—	—	—	42.7	48.2	50	60
									E09	9	1	21.7	69.8	75.3	70	80
									E18	18	2	43.3	96.8	102.3	100	110
									E24	24	2	57.7	114.8	120.3	125	125
									E36	34	2	81.8	145	150.5	150	175
	460-3-60	6.3	55	10	1.1	3.4	2.2	—	None	—	—	—	19.8	22	25	25
									E09	9	1	10.8	33.3	35.5	35	40
									E18	18	2	21.7	46.9	49.1	50	50
									E24	24	2	28.9	55.9	58.1	60	60
									E36	34	2	40.9	70.9	73.1	80	80
	575-3-60	6	41	9	0.65	2.4	1.8	—	None	—	—	—	17.2	19	20	25
									E09	9	1	8.7	28.1	29.9	30	30
									E18	18	2	17.3	38.8	40.6	40	45
									E24	24	2	23.1	46.1	47.9	50	50
									E36	34	2	32.7	58.1	59.9	60	60
120 (10)	208-3-60	15.4	155	24	1.65	6.8	5.5	—	None	—	—	—	44.8	50.3	60	60
									E18	13.5	2	37.5	91.7	97.2	100	100
									E24	18	2	50	107.3	112.8	110	125
									E36	25.5	2	70.8	133.3	138.8	150	150
									E54	40.6	2	112.7	149.4	156.3	150	175
	230-3-60	15.4	155	24	1.65	6.8	5.5	—	None	—	—	—	44.8	50.3	60	60
									E18	18	2	43.3	98.9	104.4	100	110
									E24	24	2	57.7	116.9	122.4	125	125
									E36	34	2	81.8	147.1	152.6	150	175
									E54	54	2	129.9	147.1	152.6	150	175
	460-3-60	7.1	62	11	1.1	3.4	2.2	—	None	—	—	—	21.6	23.8	25	30
									E18	18	2	21.7	48.7	50.9	50	60
									E24	24	2	28.9	57.7	59.9	60	60
									E36	34	2	40.9	72.7	74.9	80	80
									E54	54	2	65	72.7	74.9	80	80
	575-3-60	6	47.8	9	0.65	2.4	1.8	—	None	—	—	—	17.2	19	20	25
									E18	18	2	17.3	38.8	40.6	40	45
									E24	24	2	23.1	46.1	47.9	50	50
									E36	34	2	32.7	58.1	59.9	60	60
									E54	54	2	52	58.1	59.9	60	60
150 (12.5)	208-3-60	22.4	149	35	3.5	8.2	5.5	—	None	—	—	—	72.6	78.1	90	100
									E18	13.5	2	37.5	119.5	125	125	125
									E24	18	2	50	135.1	140.6	150	150
									E36	25.5	2	70.8	161.1	166.6	175	175
									E54	40.6	2	112.7	161.1	166.6	175	175
	230-3-60	22.4	149	35	3.5	8.2	5.5	—	None	—	—	—	72.6	78.1	90	100
									E18	18	2	43.3	126.7	132.2	150	150
									E24	24	2	57.7	144.7	150.2	150	175
									E36	34	2	81.8	174.9	180.4	175	200
									E54	54	2	129.9	174.9	180.4	175	200
	460-3-60	10.6	75	17	1.6	4.1	2.2	—	None	—	—	—	34.4	36.6	45	45
									E18	18	2	21.7	61.5	63.7	70	70
									E24	24	2	28.9	70.5	72.7	80	80
									E36	34	2	40.9	85.5	87.7	90	90
									E54	54	2	65	85.5	87.7	90	90

1. Minimum circuit ampacity.
2. Dual element, time delay type.
3. HACR type for NEC.

XP078-150 Hi-Static motor - without powered convenience outlet

Size (ton)	Voltage	Compressors (each)			OD fan motors (each)	Supply blower motor	Pwr Exh motor	Pwr Conv outlet	Electric heat option				MCA ¹ (Amps)	MCA ¹ w/Pwr Exh (Amps)	Max fuse ² / breaker ³ size (Amps)	Max fuse ¹ / breaker ³ size w/ Pwr Exh (Amps)
		RLA	LRA	MCC	FLA	FLA	FLA	FLA	Model	kW	Stages	Amps				
078 (6)	208-3-60	13.5	88	21	1.65	6.8	5.5	—	None	—	—	—	40.5	46	50	50
									E09	6.8	1	18.9	64.1	69.6	70	70
									E18	14	2	37.5	87.4	92.9	90	100
									E24	18	2	50	103	108.5	110	110
									E36	26	2	70.8	129	134.5	150	150
	230-3-60	13.5	88	21	1.65	6.8	5.5	—	None	—	—	—	40.5	46	50	50
									E09	9	1	21.7	67.6	73.1	70	80
									E18	18	2	43.3	94.6	100.1	100	110
									E24	24	2	57.7	112.6	118.1	125	125
									E36	34	2	81.8	142.8	148.3	150	150
	460-3-60	6	44	9	1.1	3.4	2.2	—	None	—	—	—	19.1	21.3	25	25
									E09	9	1	10.8	32.6	34.8	35	35
									E18	18	2	21.7	46.2	48.4	50	50
									E24	24	2	28.9	55.2	57.4	60	60
									E36	34	2	40.9	70.2	72.4	80	80
	575-3-60	4.9	34	8	0.65	2.4	1.8	—	None	—	—	—	14.7	16.5	15	20
									E09	9	1	8.7	25.6	27.4	30	30
									E18	18	2	17.3	36.3	38.1	40	40
									E24	24	2	23.1	43.6	45.4	45	50
									E36	34	2	32.7	55.6	57.4	60	60
090 (7.5)	208-3-60	13.7	83.1	21	1.65	9.6	5.5	—	None	—	—	—	43.7	49.2	50	60
									E09	6.8	1	18.9	67.3	72.8	70	80
									E18	13.5	2	37.5	90.6	96.1	100	100
									E24	18	2	50	106.2	111.7	110	125
									E36	25.5	2	70.8	132.2	137.7	150	150
	230-3-60	13.7	83.1	21	1.65	9.6	5.5	—	None	—	—	—	43.7	49.2	50	60
									E09	9	1	21.7	70.8	76.3	80	80
									E18	18	2	43.3	97.8	103.3	100	110
									E24	24	2	57.7	115.8	121.3	125	125
									E36	34	2	81.8	146	151.5	150	175
	460-3-60	6.2	41	10	1.1	4.7	2.2	—	None	—	—	—	20.9	23.1	25	25
									E09	9	1	10.8	34.4	36.6	35	40
									E18	18	2	21.7	48	50.2	50	60
									E24	24	2	28.9	57	59.2	60	60
									E36	34	2	40.9	72	74.2	80	80
	575-3-60	4.8	33	8	0.65	3.6	1.8	—	None	—	—	—	15.7	17.5	20	20
									E09	9	1	8.7	26.6	28.4	30	30
									E18	18	2	17.3	37.3	39.1	40	40
									E24	24	2	23.1	44.6	46.4	45	50
									E36	34	2	32.7	56.6	58.4	60	60
102 (8.5)	208-3-60	14.5	98	23	1.65	9.6	5.5	—	None	—	—	—	45.5	51	60	60
									E09	6.8	1	18.9	69.1	74.6	70	80
									E18	13.5	2	37.5	92.4	97.9	100	100
									E24	18	2	50	108	113.5	110	125
									E36	25.5	2	70.8	134	139.5	150	150
	230-3-60	14.5	98	23	1.65	9.6	5.5	—	None	—	—	—	45.5	51	60	60
									E09	9	1	21.7	72.6	78.1	80	80
									E18	18	2	43.3	99.6	105.1	100	110
									E24	24	2	57.7	117.6	123.1	125	125
									E36	34	2	81.8	147.8	153.3	150	175
	460-3-60	6.3	55	10	1.1	4.7	2.2	—	None	—	—	—	21.1	23.3	25	25
									E09	9	1	10.8	34.6	36.8	35	40
									E18	18	2	21.7	48.2	50.4	50	60
									E24	24	2	28.9	57.2	59.4	60	60
									E36	34	2	40.9	72.2	74.4	80	80
	575-3-60	6	41	9	0.65	3.6	1.8	—	None	—	—	—	18.4	20.2	20	25
									E09	9	1	8.7	29.3	31.1	30	35
									E18	18	2	17.3	40	41.8	40	45
									E24	24	2	23.1	47.3	49.1	50	50
									E36	34	2	32.7	59.3	61.1	60	70

XP078-150 Hi-Static motor - without powered convenience outlet (Continued)

Size (ton)	Voltage	Compressors (each)			OD fan motors (each)	Supply blower motor	Pwr Exh motor	Pwr Conv outlet	Electric heat option				MCA ¹ (Amps)	MCA ¹ w/Pwr Exh (Amps)	Max fuse ² / breaker ³ size (Amps)	Max fuse ¹ / breaker ³ size w/ Pwr Exh (Amps)
		RLA	LRA	MCC	FLA	FLA	FLA	FLA	Model	kW	Stages	Amps				
120 (10)	208-3-60	15.4	155	24	1.65	9.6	5.5	—	None	—	—	—	47.6	53.1	60	60
									E18	14	2	37.5	94.5	100	100	100
									E24	18	2	50	110.1	115.6	125	125
									E36	26	2	70.8	136.1	141.6	150	150
									E54	41	2	113	152.9	159.8	175	175
	230-3-60	15.4	155	24	1.65	9.6	5.5	—	None	—	—	—	47.6	53.1	60	60
									E18	18	2	43.3	101.7	107.2	110	110
									E24	24	2	57.7	119.7	125.2	125	150
									E36	34	2	81.8	149.9	155.4	150	175
									E54	54	2	130	149.9	155.4	175	175
	460-3-60	7.1	62	11	1.1	4.7	2.2	—	None	—	—	—	22.9	25.1	30	30
									E18	18	2	21.7	50	52.2	50	60
									E24	24	2	28.9	59	61.2	60	70
									E36	34	2	40.9	74	76.2	80	80
									E54	54	2	65	74	76.2	80	80
	575-3-60	6	47.8	9	0.65	3.6	1.8	—	None	—	—	—	18.4	20.2	20	25
E18									18	2	17.3	40	41.8	40	45	
E24									24	2	23.1	47.3	49.1	50	50	
E36									34	2	32.7	59.3	61.1	60	70	
E54									54	2	52	59.3	61.1	70	70	
150 (12.5)	208-3-60	22.4	149	35	3.5	14	5.5	—	None	—	—	—	78.4	83.9	100	100
									E18	14	2	37.5	125.3	130.8	150	150
									E24	18	2	50	140.9	146.4	150	150
									E36	26	2	70.8	166.9	172.4	175	175
									E54	41	2	113	166.9	172.4	175	175
	230-3-60	22.4	149	35	3.5	14	5.5	—	None	—	—	—	78.4	83.9	100	100
									E18	18	2	43.3	132.5	138	150	150
									E24	24	2	57.7	150.5	156	175	175
									E36	34	2	81.8	180.7	186.2	200	200
									E54	54	2	130	180.7	186.2	200	200
	460-3-60	10.6	75	17	1.6	6.6	2.2	—	None	—	—	—	36.9	39.1	45	45
									E18	18	2	21.7	64	66.2	70	70
									E24	24	2	28.9	73	75.2	80	80
									E36	34	2	40.9	88	90.2	90	100
									E54	54	2	65	88	90.2	90	100

1. Minimum circuit ampacity.
2. Dual element, time delay type.
3. HACR type per NEC.

XP078-150 Standard motor - with powered convenience outlet

Size (ton)	Voltage	Compressors (each)			OD fan motors (each)	Supply blower motor	Pwr Exh motor	Pwr Conv outlet	Electric heat option				MCA ¹ (Amps)	MCA ¹ w/Pwr Exh (Amps)	Max fuse ² / breaker ³ size (Amps)	Max fuse ¹ / breaker ³ size w/ Pwr Exh (Amps)
		RLA	LRA	MCC	FLA	FLA	FLA	FLA	Model	kW	Stages	Amps				
078 (6)	208-3-60	13.5	88	21	1.65	5.2	5.5	20	None	—	—	—	48.9	54.4	60	60
									E09	6.8	1	18.9	72.5	78	80	80
									E18	13.5	2	37.5	95.8	101.3	100	110
									E24	18	2	50	111.4	116.9	125	125
									E36	25.5	2	70.8	137.4	142.9	150	150
	230-3-60	13.5	88	21	1.65	5.2	5.5	20	None	—	—	—	48.9	54.4	60	60
									E09	9	1	21.7	76	81.5	80	90
									E18	18	2	43.3	103	108.5	110	110
									E24	24	2	57.7	121	126.5	125	150
									E36	34	2	81.8	151.2	156.7	175	175
	460-3-60	6	44	9	1.1	2.6	2.2	20	None	—	—	—	23.3	25.5	25	30
									E09	9	1	10.8	36.8	39	40	40
									E18	18	2	21.7	50.4	52.6	60	60
									E24	24	2	28.9	59.4	61.6	60	70
									E36	34	2	40.9	74.4	76.6	80	80
	575-3-60	4.9	34	8	0.65	2	1.8	20	None	—	—	—	18.3	20.1	20	25
									E09	9	1	8.7	29.2	31	30	35
									E18	18	2	17.3	39.9	41.7	40	45
									E24	24	2	23.1	47.2	49	50	50
									E36	34	2	32.7	59.2	61	60	70
090 (7.5)	208-3-60	13.7	83.1	21	1.65	5.2	5.5	20	None	—	—	—	49.3	54.8	60	60
									E09	6.8	1	18.9	72.9	78.4	80	80
									E18	13.5	2	37.5	96.2	101.7	100	110
									E24	18	2	50	111.8	117.3	125	125
									E36	25.5	2	70.8	137.8	143.3	150	150
	230-3-60	13.7	83.1	21	1.65	5.2	5.5	20	None	—	—	—	49.3	54.8	60	60
									E09	9	1	21.7	76.4	81.9	80	90
									E18	18	2	43.3	103.4	108.9	110	110
									E24	24	2	57.7	121.4	126.9	125	150
									E36	34	2	81.8	151.6	157.1	175	175
	460-3-60	6.2	41	10	1.1	2.6	2.2	20	None	—	—	—	23.8	26	30	30
									E09	9	1	10.8	37.3	39.5	40	40
									E18	18	2	21.7	50.9	53.1	60	60
									E24	24	2	28.9	59.9	62.1	60	70
									E36	34	2	40.9	74.9	77.1	80	80
	575-3-60	4.8	33	8	0.65	2	1.8	20	None	—	—	—	18.1	19.9	20	20
									E09	9	1	8.7	29	30.8	30	35
									E18	18	2	17.3	39.7	41.5	40	45
									E24	24	2	23.1	47	48.8	50	50
									E36	34	2	32.7	59	60.8	60	70
102 (8.5)	208-3-60	14.5	98	23	1.65	6.8	5.5	20	None	—	—	—	52.7	58.2	60	70
									E09	6.8	1	18.9	76.3	81.8	80	90
									E18	13.5	2	37.5	99.6	105.1	100	110
									E24	18	2	50	115.2	120.7	125	125
									E36	25.5	2	70.8	141.2	146.7	150	150
	230-3-60	14.5	98	23	1.65	6.8	5.5	20	None	—	—	—	52.7	58.2	60	70
									E09	9	1	21.7	79.8	85.3	80	90
									E18	18	2	43.3	106.8	112.3	110	125
									E24	24	2	57.7	124.8	130.3	125	150
									E36	34	2	81.8	155	160.5	175	175
	460-3-60	6.3	55	10	1.1	3.4	2.2	20	None	—	—	—	24.8	27	30	30
									E09	9	1	10.8	38.3	40.5	40	45
									E18	18	2	21.7	51.9	54.1	60	60
									E24	24	2	28.9	60.9	63.1	70	70
									E36	34	2	40.9	75.9	78.1	80	80
	575-3-60	6	41	9	0.65	2.4	1.8	20	None	—	—	—	21.2	23	25	25
									E09	9	1	8.7	32.1	33.9	35	35
									E18	18	2	17.3	42.8	44.6	45	45
									E24	24	2	23.1	50.1	51.9	60	60
									E36	34	2	32.7	62.1	63.9	70	70

XP078-150 Standard motor - with powered convenience outlet (Continued)

Size (ton)	Voltage	Compressors (each)			OD fan motors (each)	Supply blower motor	Pwr Exh motor	Pwr Conv outlet	Electric heat option				MCA ¹ (Amps)	MCA ¹ w/Pwr Exh (Amps)	Max fuse ^{2/} breaker ³ size (Amps)	Max fuse ^{1/} breaker ³ size w/ Pwr Exh (Amps)
		RLA	LRA	MCC	FLA	FLA	FLA	FLA	Model	kW	Stages	Amps				
120 (10)	208-3-60	15.4	155	24	1.65	6.8	5.5	20	None	—	—	—	54.8	60.3	70	70
									E18	13.5	2	37.5	101.7	107.2	110	110
									E24	18	2	50	117.3	122.8	125	125
									E36	25.5	2	70.8	143.3	148.8	150	150
									E54	40.6	2	112.7	161.9	168.8	175	175
	230-3-60	15.4	155	24	1.65	6.8	5.5	20	None	—	—	—	54.8	60.3	70	70
									E18	18	2	43.3	108.9	114.4	110	125
									E24	24	2	57.7	126.9	132.4	150	150
									E36	34	2	81.8	157.1	162.6	175	175
									E54	54	2	129.9	157.1	162.6	175	175
	460-3-60	7.1	62	11	1.1	3.4	2.2	20	None	—	—	—	26.6	28.8	30	35
									E18	18	2	21.7	53.7	55.9	60	60
									E24	24	2	28.9	62.7	64.9	70	70
									E36	34	2	40.9	77.7	79.9	80	80
									E54	54	2	65	77.7	79.9	80	90
	575-3-60	6	47.8	9	0.65	2.4	1.8	20	None	—	—	—	21.2	23.0	25	25
E18									18	2	17.3	42.8	44.6	45	45	
E24									24	2	23.1	50.1	51.9	60	60	
E36									34	2	32.7	62.1	63.9	70	70	
E54									54	2	52	62.1	63.9	70	70	
150 (12.5)	208-3-60	22.4	149	35	3.5	8.2	5.5	20	None	—	—	—	82.6	88.1	100	110
									E18	13.5	2	37.5	129.5	135	150	150
									E24	18	2	50	145.1	150.6	150	175
									E36	25.5	2	70.8	171.1	176.6	175	200
									E54	40.6	2	112.7	171.1	176.6	175	200
	230-3-60	22.4	149	35	3.5	8.2	5.5	20	None	—	—	—	82.6	88.1	100	110
									E18	18	2	43.3	136.7	142.2	150	150
									E24	24	2	57.7	154.7	160.2	175	175
									E36	34	2	81.8	184.9	190.4	200	200
									E54	54	2	129.9	184.9	190.4	200	200
	460-3-60	10.6	75	17	1.6	4.1	2.2	20	None	—	—	—	39.4	41.6	50	50
									E18	18	2	21.7	66.5	68.7	70	70
									E24	24	2	28.9	75.5	77.7	80	80
									E36	34	2	40.9	90.5	92.7	100	100
									E54	54	2	65	90.5	92.7	100	100

1. Minimum circuit ampacity.
2. Dual element, time delay type.
3. HACR type per NEC.

XP078-150 Hi-Static motor - with powered convenience outlet

Size (ton)	Voltage	Compressors (each)			OD Fan Motors (each)	Supply Blower Motor	Pwr Exh Motor	Pwr Conv Outlet	Electric Heat Option				MCA ¹ (Amps)	MCA ¹ w/Pwr Exh (Amps)	Max Fuse ² / Breaker ³ Size (Amps)	Max Fuse ² / Breaker ³ Size w/ Pwr Exh (Amps)
		RLA	LRA	MCC	FLA	FLA	FLA	FLA	Model	kW	Stages	Amps				
078 (6)	208-3-60	13.5	88	21	1.65	6.8	5.5	20	None	—	—	—	50.5	56	60	60
									E09	6.8	1	18.9	74.1	79.6	80	80
									E18	14	2	37.5	97.4	102.9	100	110
									E24	18	2	50	113	118.5	125	125
									E36	26	2	70.8	139	144.5	150	150
	230-3-60	13.5	88	21	1.65	6.8	5.5	20	None	—	—	—	50.5	56	60	60
									E09	9	1	21.7	77.6	83.1	80	90
									E18	18	2	43.3	104.6	110.1	110	125
									E24	24	2	57.7	122.6	128.1	125	150
									E36	34	2	81.8	152.8	158.3	175	175
	460-3-60	6	44	9	1.1	3.4	2.2	20	None	—	—	—	24.1	26.3	30	30
									E09	9	1	10.8	37.6	39.8	40	40
									E18	18	2	21.7	51.2	53.4	60	60
									E24	24	2	28.9	60.2	62.4	70	70
									E36	34	2	40.9	75.2	77.4	80	80
	575-3-60	4.9	34	8	0.65	2.4	1.8	20	None	—	—	—	18.7	20.5	20	25
									E09	9	1	8.7	29.6	31.4	30	35
									E18	18	2	17.3	40.3	42.1	45	45
									E24	24	2	23.1	47.6	49.4	50	50
									E36	34	2	32.7	59.6	61.4	60	70
090 (7.5)	208-3-60	13.7	83.1	21	1.65	9.6	5.5	20	None	—	—	—	53.7	59.2	60	70
									E09	6.8	1	18.9	77.3	82.8	80	90
									E18	13.5	2	37.5	100.6	106.1	110	110
									E24	18	2	50	116.2	121.7	125	125
									E36	25.5	2	70.8	142.2	147.7	150	150
	230-3-60	13.7	83.1	21	1.65	9.6	5.5	20	None	—	—	—	53.7	59.2	60	70
									E09	9	1	21.7	80.8	86.3	90	90
									E18	18	2	43.3	107.8	113.3	110	125
									E24	24	2	57.7	125.8	131.3	150	150
									E36	34	2	81.8	156	161.5	175	175
	460-3-60	6.2	41	10	1.1	4.7	2.2	20	None	—	—	—	25.9	28.1	30	30
									E09	9	1	10.8	39.4	41.6	40	45
									E18	18	2	21.7	53	55.2	60	60
									E24	24	2	28.9	62	64.2	70	70
									E36	34	2	40.9	77	79.2	80	80
	575-3-60	4.8	33	8	0.65	3.6	1.8	20	None	—	—	—	19.7	21.5	20	25
									E09	9	1	8.7	30.6	32.4	35	35
									E18	18	2	17.3	41.3	43.1	45	45
									E24	24	2	23.1	48.6	50.4	50	60
									E36	34	2	32.7	60.6	62.4	70	70
102 (8.5)	208-3-60	14.5	98	23	1.65	9.6	5.5	20	None	—	—	—	55.5	61	70	70
									E09	6.8	1	18.9	79.1	84.6	80	90
									E18	13.5	2	37.5	102.4	107.9	110	110
									E24	18	2	50	118	123.5	125	125
									E36	25.5	2	70.8	144	149.5	150	150
	230-3-60	14.5	98	23	1.65	9.6	5.5	20	None	—	—	—	55.5	61	70	70
									E09	9	1	21.7	82.6	88.1	90	90
									E18	18	2	43.3	109.6	115.1	110	125
									E24	24	2	57.7	127.6	133.1	150	150
									E36	34	2	81.8	157.8	163.3	175	175
	460-3-60	6.3	55	10	1.1	4.7	2.2	20	None	—	—	—	26.1	28.3	30	30
									E09	9	1	10.8	39.6	41.8	40	45
									E18	18	2	21.7	53.2	55.4	60	60
									E24	24	2	28.9	62.2	64.4	70	70
									E36	34	2	40.9	77.2	79.4	80	80
	575-3-60	6	41	9	0.65	3.6	1.8	20	None	—	—	—	22.4	24.2	25	30
									E09	9	1	8.7	33.3	35.1	35	40
									E18	18	2	17.3	44	45.8	45	50
									E24	24	2	23.1	51.3	53.1	60	60
									E36	34	2	32.7	63.3	65.1	70	70

XP078-150 Hi-Static motor - with powered convenience outlet (Continued)

Size (ton)	Voltage	Compressors (each)			OD Fan Motors (each)	Supply Blower Motor	Pwr Exh Motor	Pwr Conv Outlet	Electric Heat Option				MCA ¹ (Amps)	MCA ¹ w/Pwr Exh (Amps)	Max Fuse ^{2/} Breaker ³ Size (Amps)	Max Fuse ^{2/} Breaker ³ Size w/ Pwr Exh (Amps)
		RLA	LRA	MCC	FLA	FLA	FLA	FLA	Model	kW	Stages	Amps				
120 (10)	208-3-60	15.4	155	24	1.65	9.6	5.5	20	None	—	—	—	57.6	63.1	70	70
									E18	14	2	37.5	104.5	110	110	110
									E24	18	2	50	120.1	125.6	125	150
									E36	26	2	70.8	146.1	151.6	150	175
									E54	41	2	113	165.4	172.3	175	175
	230-3-60	15.4	155	24	1.65	9.6	5.5	20	None	—	—	—	57.6	63.1	70	70
									E18	18	2	43.3	111.7	117.2	125	125
									E24	24	2	57.7	129.7	135.2	150	150
									E36	34	2	81.8	159.9	165.4	175	175
									E54	54	2	130	159.9	165.4	175	175
	460-3-60	7.1	62	11	1.1	4.7	2.2	20	None	—	—	—	27.9	30.1	35	35
									E18	18	2	21.7	55	57.2	60	60
									E24	24	2	28.9	64	66.2	70	70
									E36	34	2	40.9	79	81.2	80	90
									E54	54	2	65	79	81.2	90	90
	575-3-60	6	47.8	9	0.65	3.6	1.8	20	None	—	—	—	22.4	24.2	25	30
									E18	18	2	17.3	44	45.8	45	50
									E24	24	2	23.1	51.3	53.1	60	60
									E36	34	2	32.7	63.3	65.1	70	70
									E54	54	2	52	63.3	65.1	70	70
150 (12.5)	208-3-60	22.4	149	35	3.5	14	5.5	20	None	—	—	—	88.4	93.9	110	110
									E18	14	2	37.5	135.3	140.8	150	150
									E24	18	2	50	150.9	156.4	175	175
									E36	26	2	70.8	176.9	182.4	200	200
									E54	41	2	113	176.9	182.4	200	200
	230-3-60	22.4	149	35	3.5	14	5.5	20	None	—	—	—	88.4	93.9	110	110
									E18	18	2	43.3	142.5	148	150	150
									E24	24	2	57.7	160.5	166	175	175
									E36	34	2	81.8	190.7	196.2	200	200
									E54	54	2	130	190.7	196.2	200	200
	460-3-60	10.6	75	17	1.6	6.6	2.2	20	None	—	—	—	41.9	44.1	50	50
									E18	18	2	21.7	69	71.2	70	80
									E24	24	2	28.9	78	80.2	80	90
									E36	34	2	40.9	93	95.2	100	100
									E54	54	2	65	93	95.2	100	100

1. Minimum Circuit Ampacity.
2. Dual Element, Time Delay Type.
3. HACR type per NEC.

Typical wiring diagrams

XP078-150 typical wiring diagrams

Typical XP078-120 heat pump with/without electric heat wiring diagram

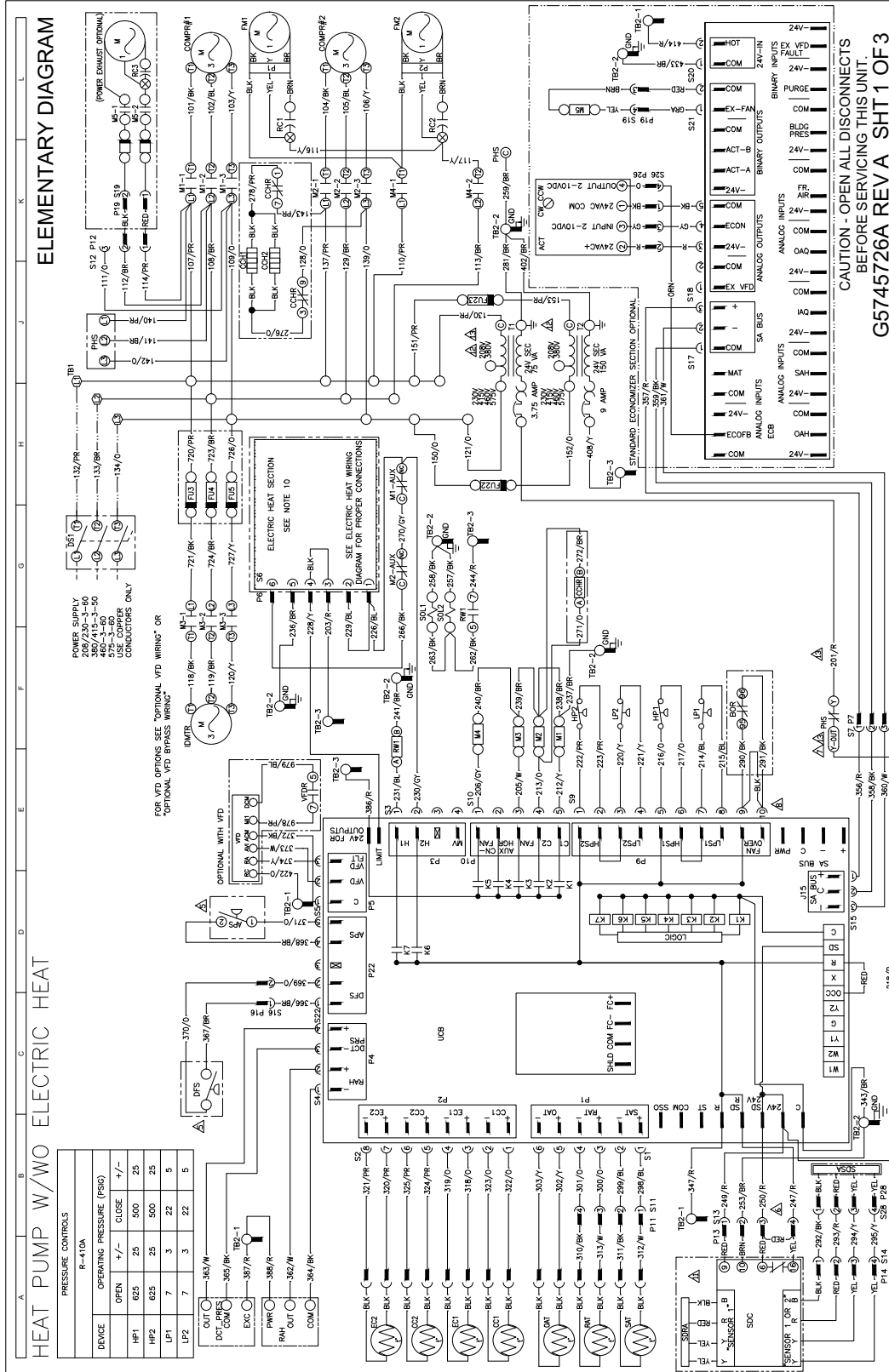

Typical XP150 heat pump with/without electric heat wiring diagram

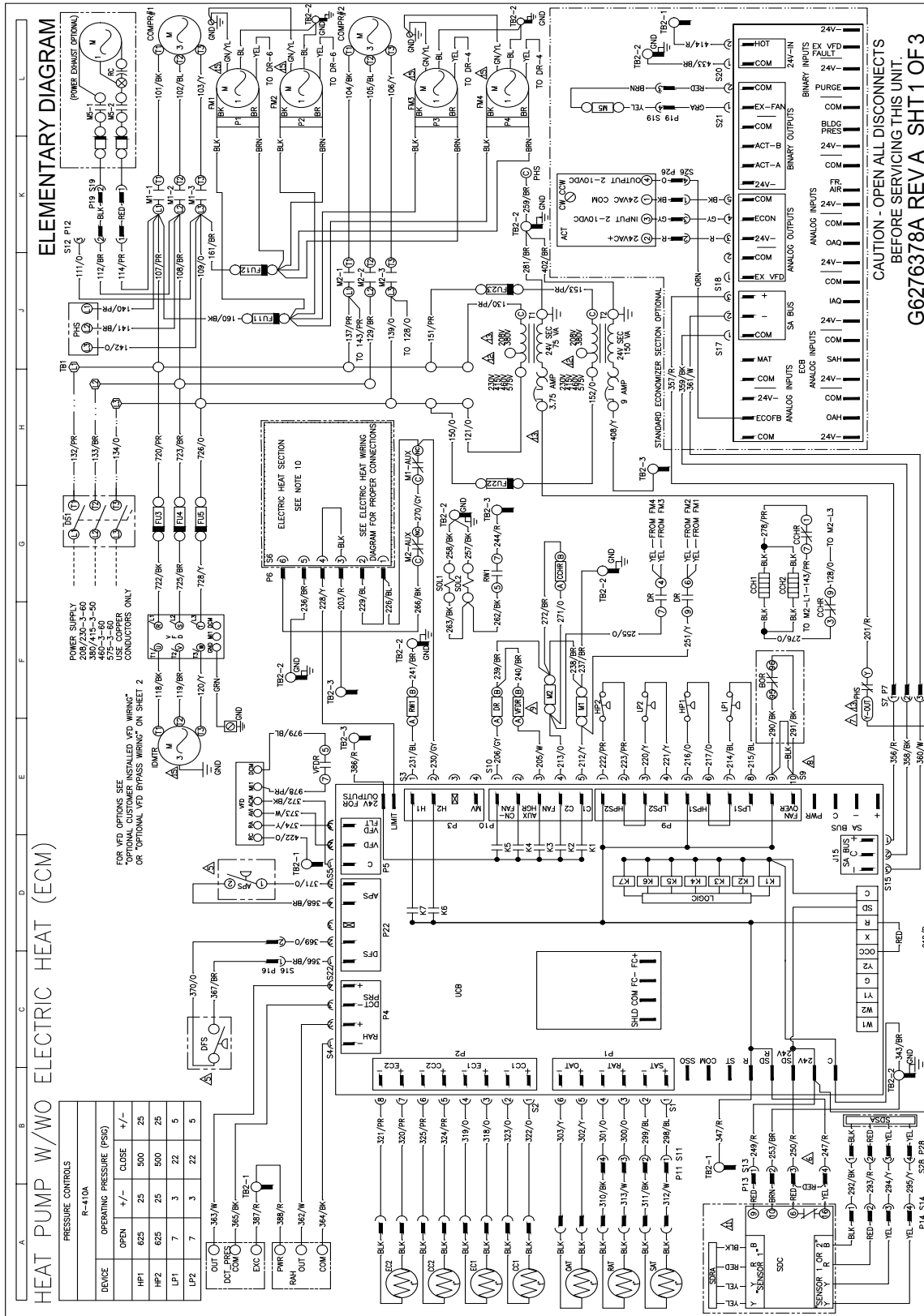

Typical CPC BAS control wiring diagram

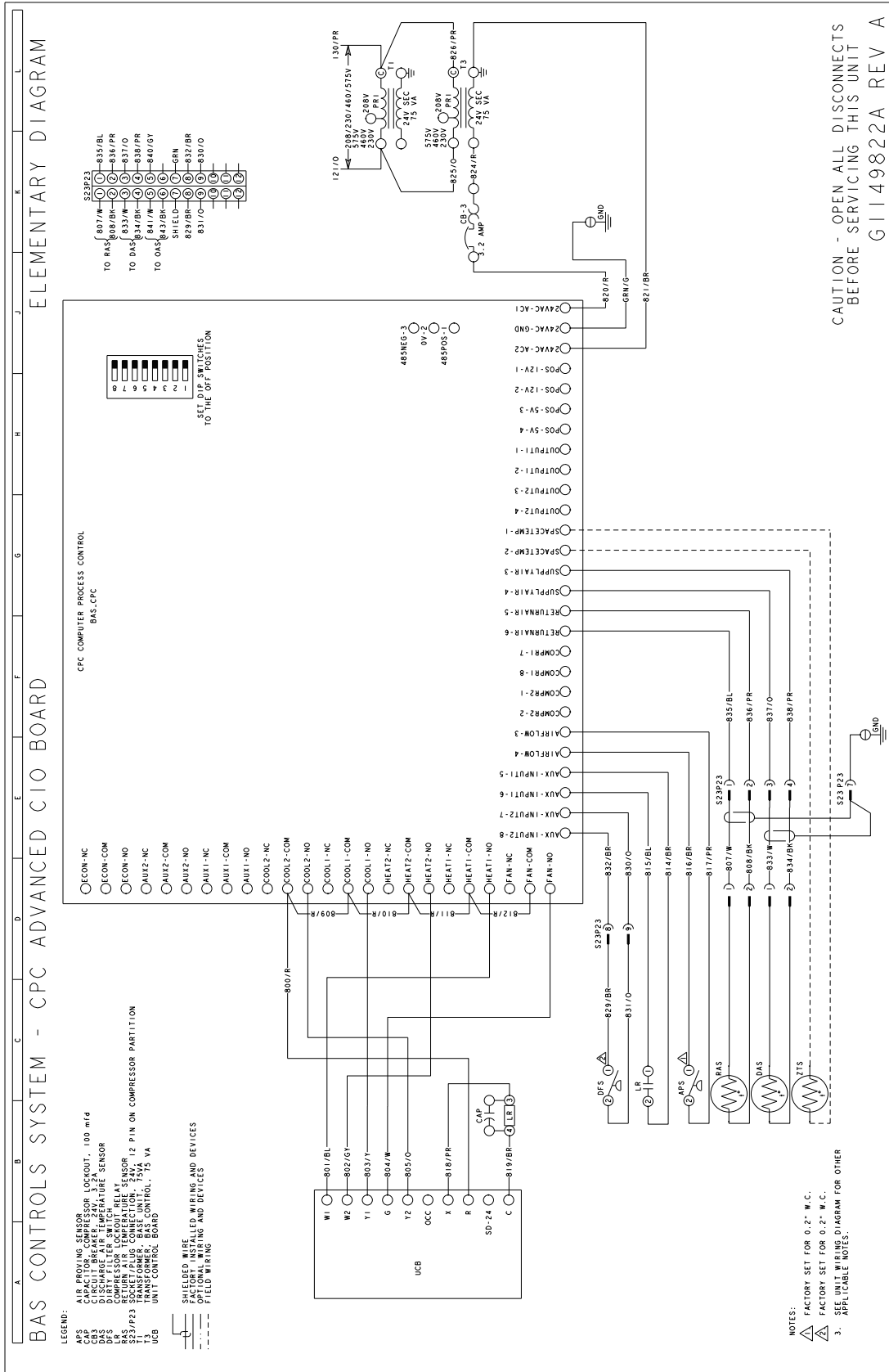

Typical Honeywell BAS control wiring diagram

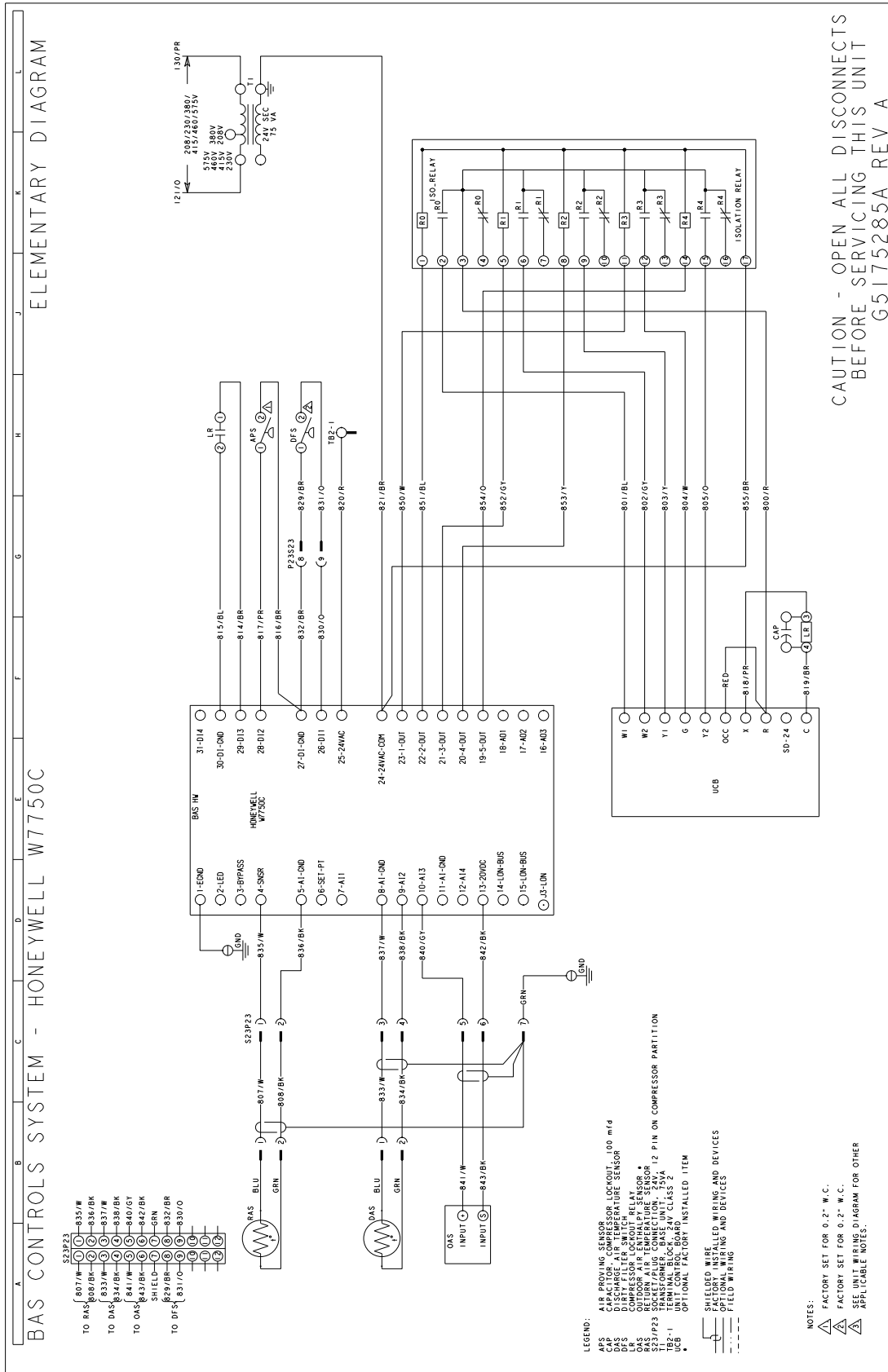

Weights and dimensions

XP078-150 unit weights

Unit 4 point load weight

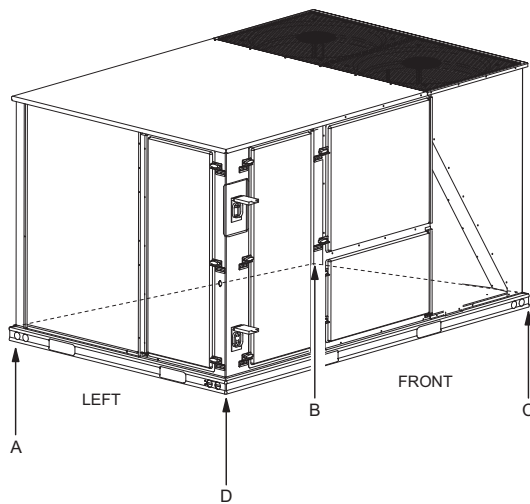

Unit 6 point load weight

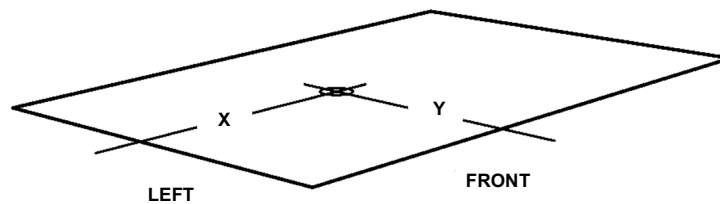
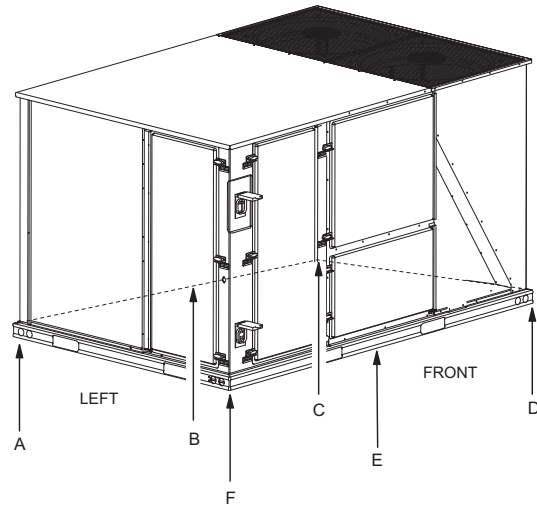

Size (ton)	Model	Weight (lb)		Center of gravity		4 point load location (lb)				6 point load location (lb)					
		Shipping	operating	X	Y	A	B	C	D	A	B	C	D	E	F
078 (6.5)	XP	1085	1080	38	25	262	195	266	357	184	150	124	169	204	250
090 (7.5)	XP	1095	1090	38	23	243	181	284	381	171	139	115	181	217	267
102 (8.5)	XP	1142	1137	38	25.5	282	210	276	370	197	161	133	175	211	259
120 (10)	XP	1140	1135	38	25.5	281	209	275	369	197	160	133	175	211	259
150 (12.5)	XP	1408	1403	51	25.5	259	347	456	340	165	198	244	320	260	216

XP078-150 Unit Accessory Weights

Unit accessory	Weight (lb)	
	Shipping	Operating
Economizer	90	85
Power exhaust	40	35
Electric heat ¹	49	49

1. Weight given is for the maximum heater size available 54kW.

XP078-150 unit dimensions
XP078-120

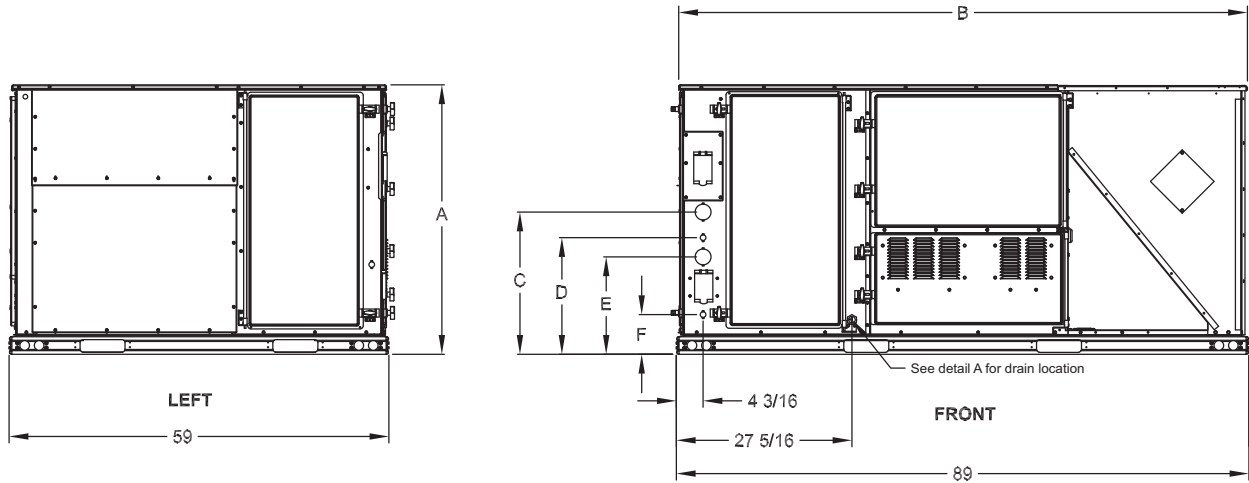

XP150

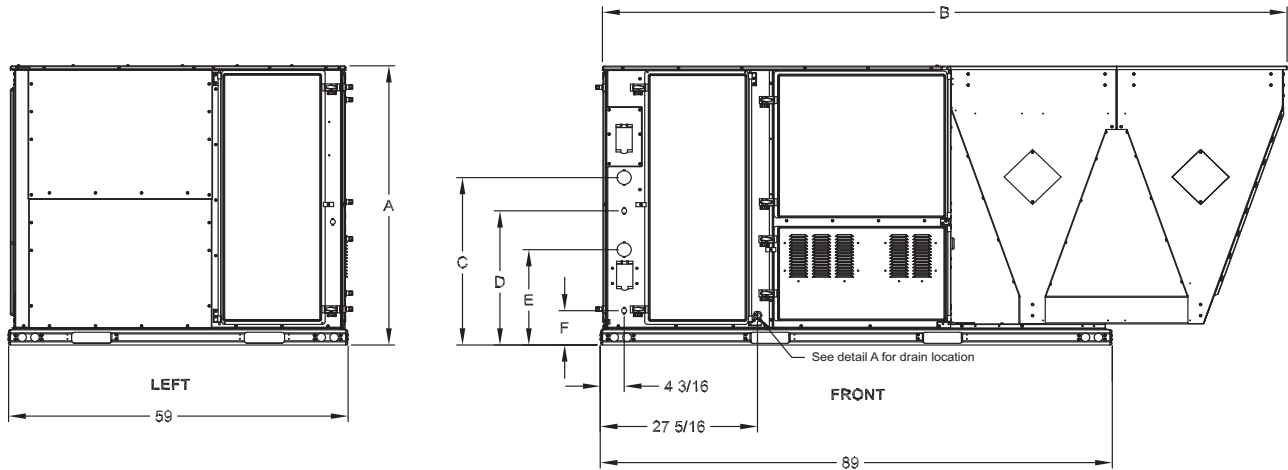

XP078-150 unit physical dimensions

Unit model number	Dimension (in.)					
	A	B	C	D	E	F
078	50 3/4	89	30 3/16	24 3/16	17 3/16	6 3/16
090	50 3/4	89	30 3/16	24 3/16	17 3/16	6 3/16
102	50 3/4	89	30 3/16	24 3/16	17 3/16	6 3/16
120	50 3/4	89	30 3/16	24 3/16	17 3/16	6 3/16
150	50 3/4	119 1/2	30 3/16	24 3/16	17 3/16	6 3/16

Detail A

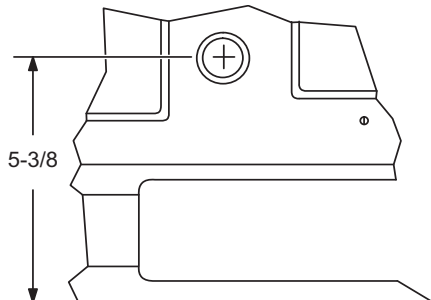

XP078-150 unit clearances

Direction	Distance (in.)	Direction	Distance (in.)
Top ¹	72	Right	12
Front	36	Left	36
Rear	36	Bottom ²	0

1. Units must be installed outdoors. Make sure that overhanging structures or shrubs do not obscure the condenser air discharge outlet.
2. Units may be installed on combustable floors made from wood or class A, B or C roof covering materials.

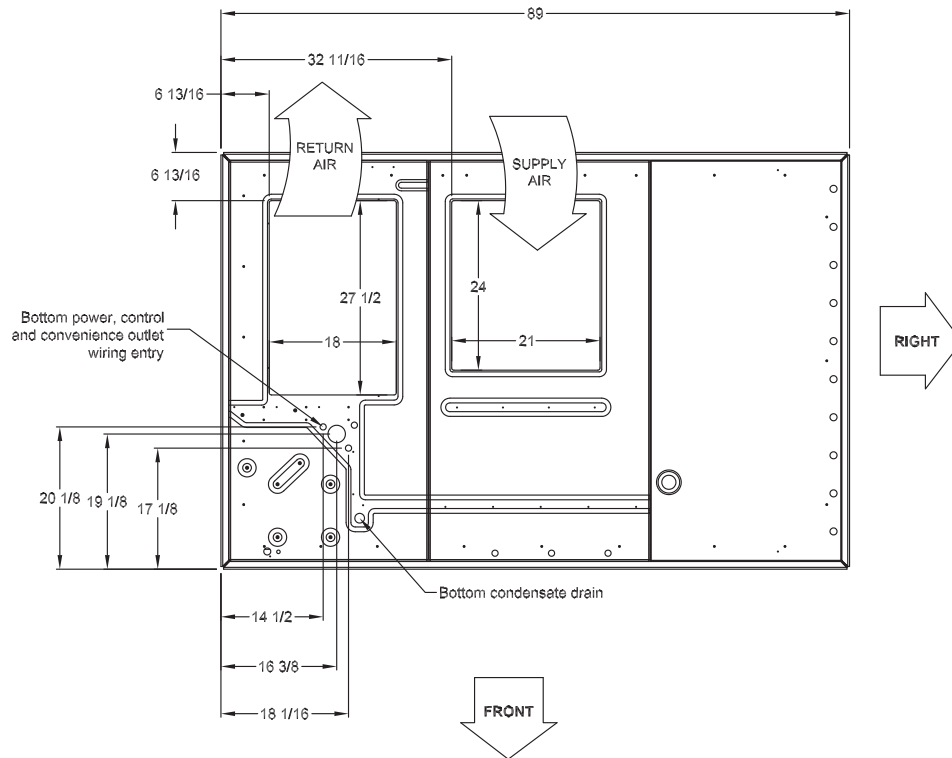
XP078-150 Unit Bottom Duct Openings

XP078-150 unit electrical entry

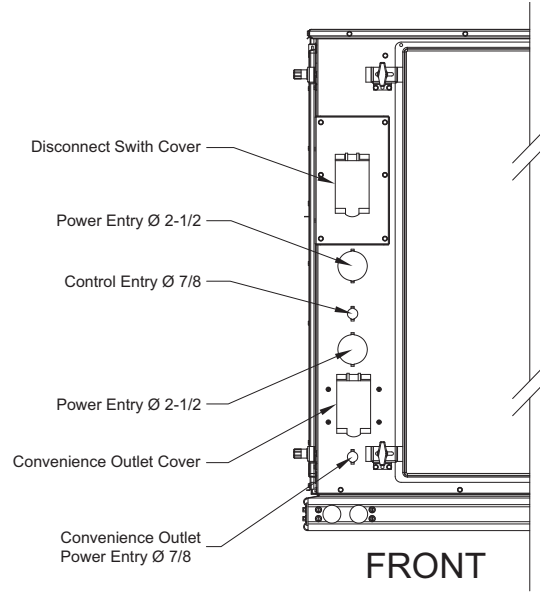

XP078-120 unit side duct openings

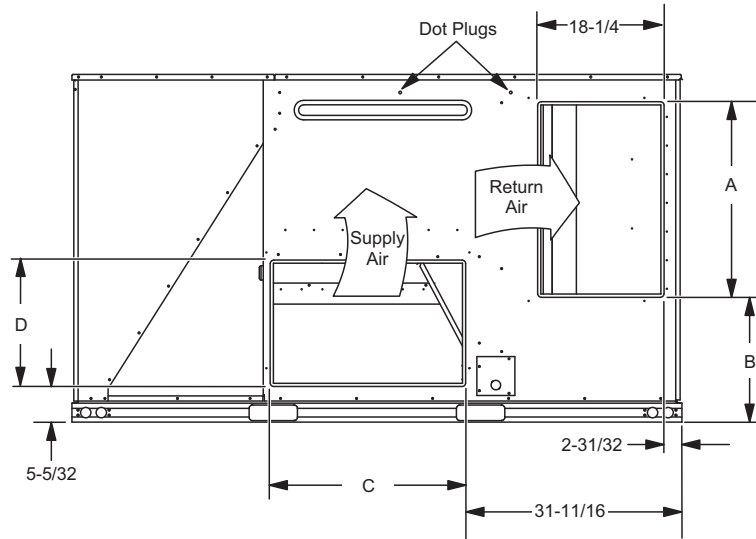

XP150 unit side duct openings

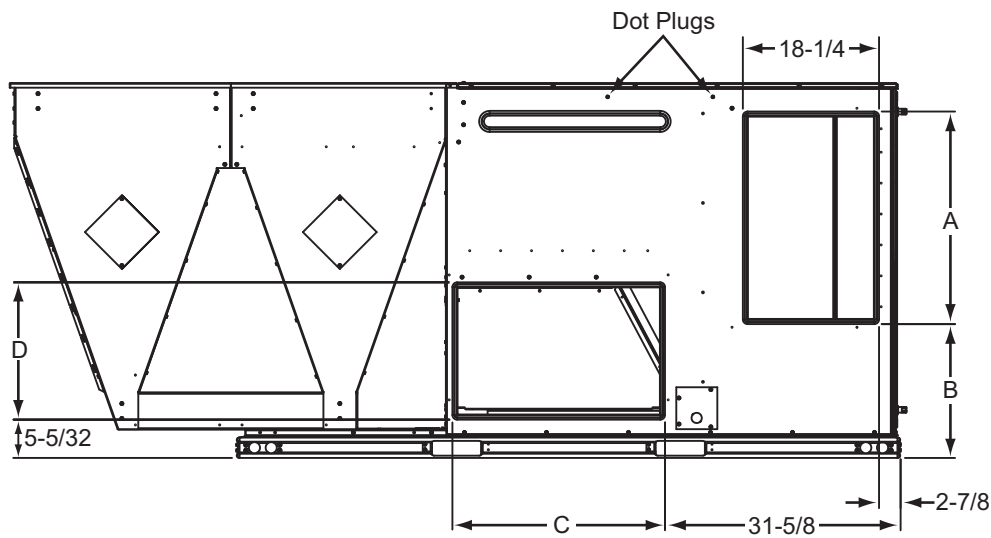

Side duct dimensions

Unit model number	Dimension (in.)			
	A	B	C	D
078	28 1/4	18 1/16	28 1/4	18 1/4
090	28 1/4	18 1/16	28 1/4	18 1/4
102	28 1/4	18 1/16	28 1/4	18 1/4
120	28 1/4	18 1/16	28 1/4	18 1/4
150	28 1/4	18 1/16	28 1/4	18 1/4

XP078-150 unit left duct opening

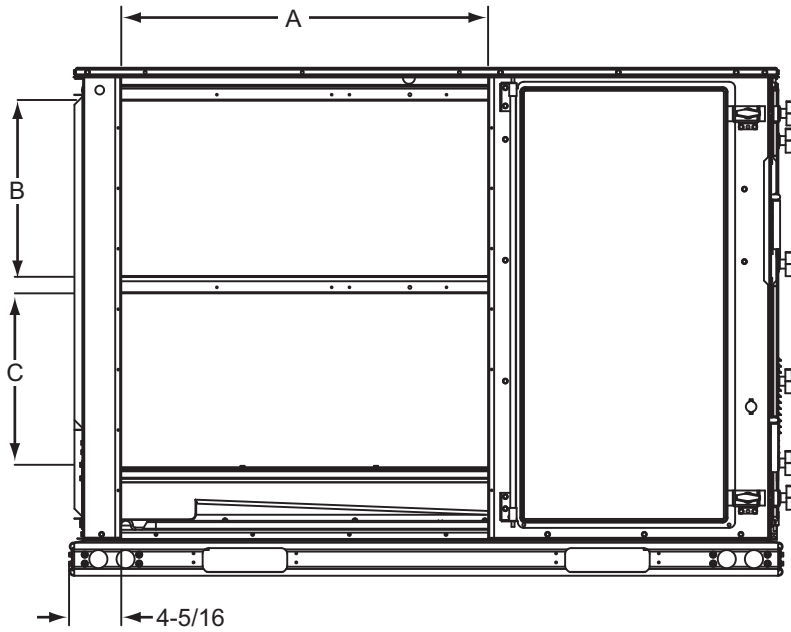

Left/end duct dimensions

Unit model number	Dimension (in.)		
	A	B	C
078	30.358	22.580	22.330
090	30.358	22.580	22.330
102	30.358	22.580	22.330
120	30.358	22.580	22.330
150	30.358	22.580	22.330

XP078-150 unit accessory dimensions

XP078-150 roof curb

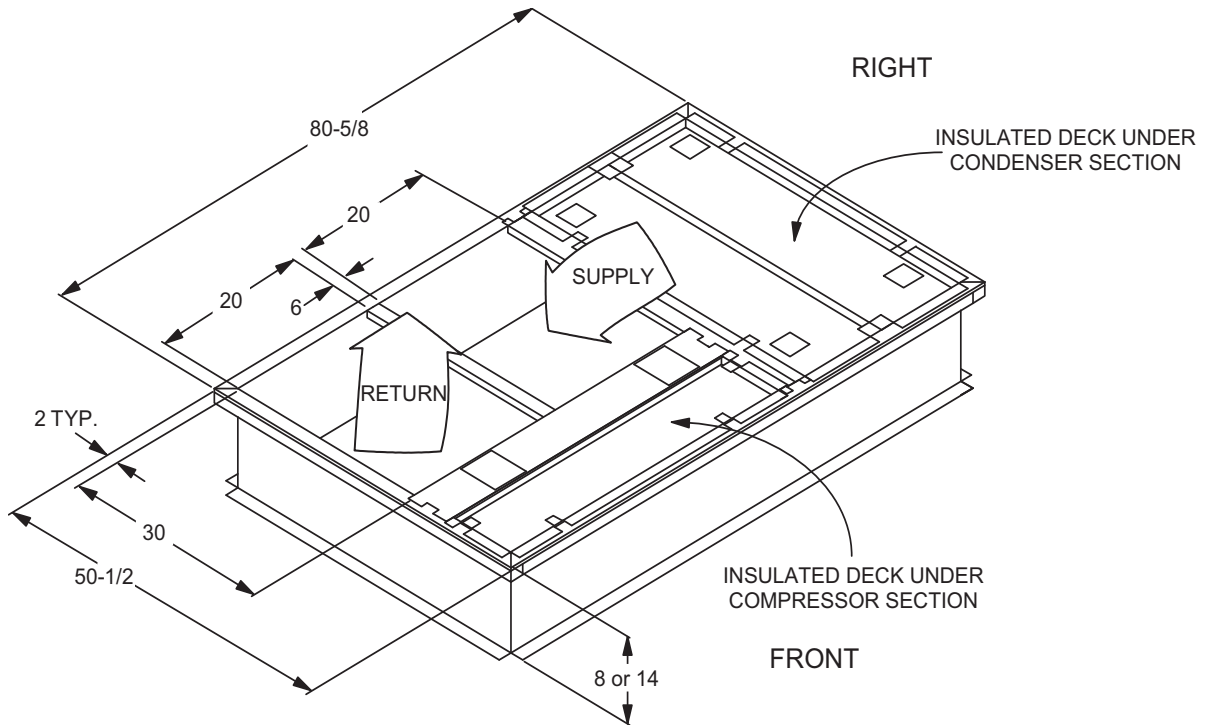

XP078-150 transition roof curb

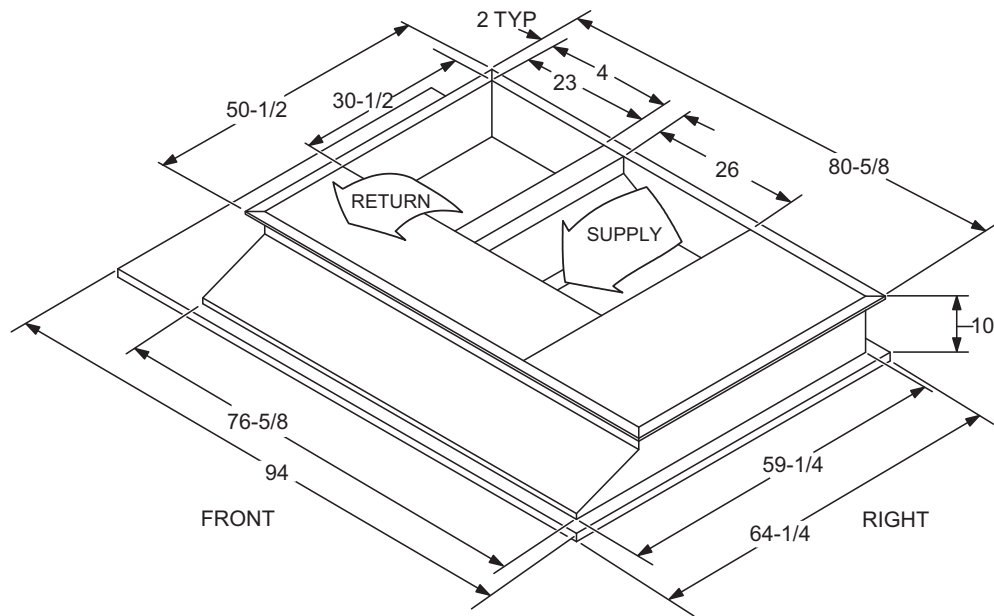

XP078-150 roof curb cut away

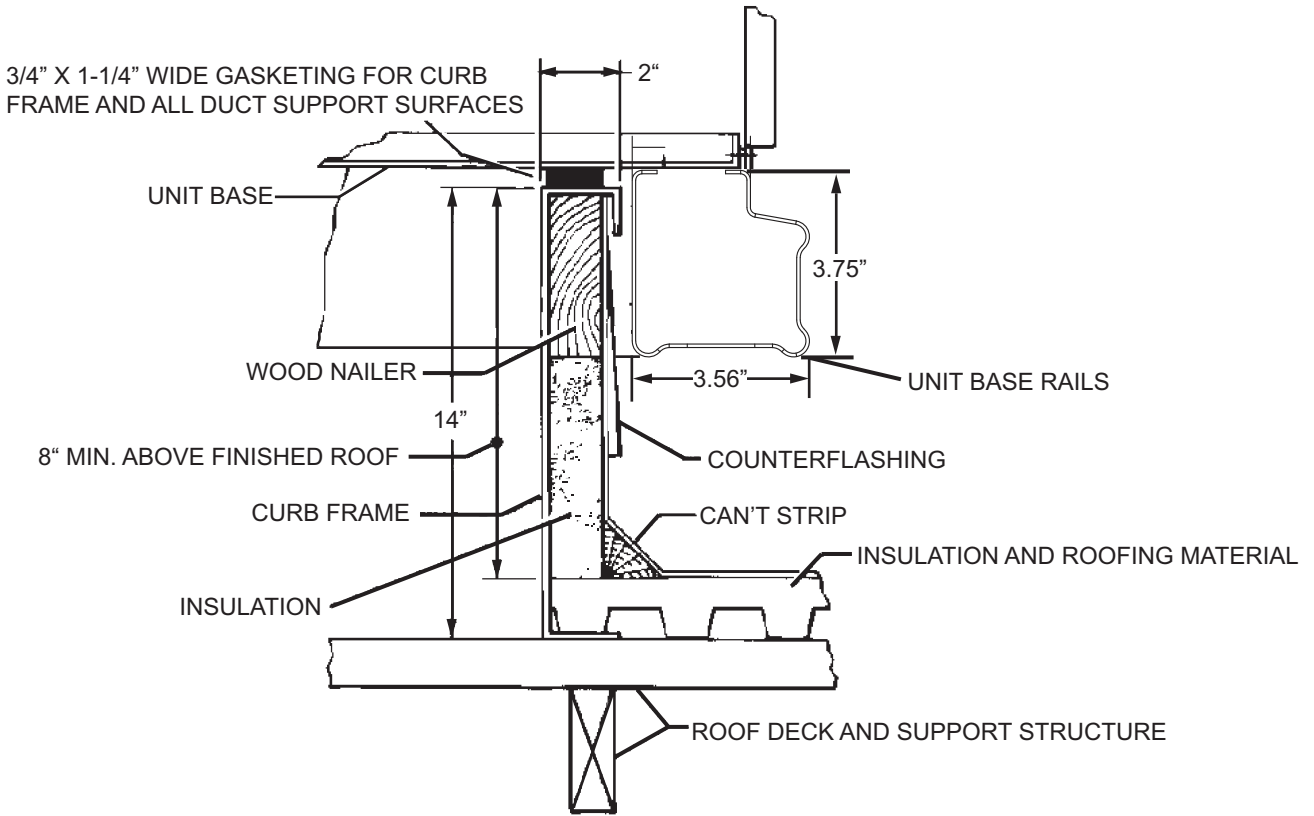

Economizer options

Economizer Usage

Application	Cabinet Height	Description	Model
Side return	All	Horizontal economizer without barometric relief	2EE04706924 ¹
Downflow, end return horizontal or bottom return vertical	42 in.	Economizer, 42 in. tall cabinet	2EE04717425 ²
		Economizer, 42 in. tall cabinet, BAS Ready	2EE04709725 ²
	50 in.	Economizer, 50 in. tall cabinet	2EE04717625 ²
		Economizer, 50 in. tall cabinet, BAS Ready	2EE04709825 ²

1. Barometric relief must be ordered separately and installed in duct work.
2. Includes fresh air hood, exhaust hood and barometric relief.

Economizer downflow with power exhaust

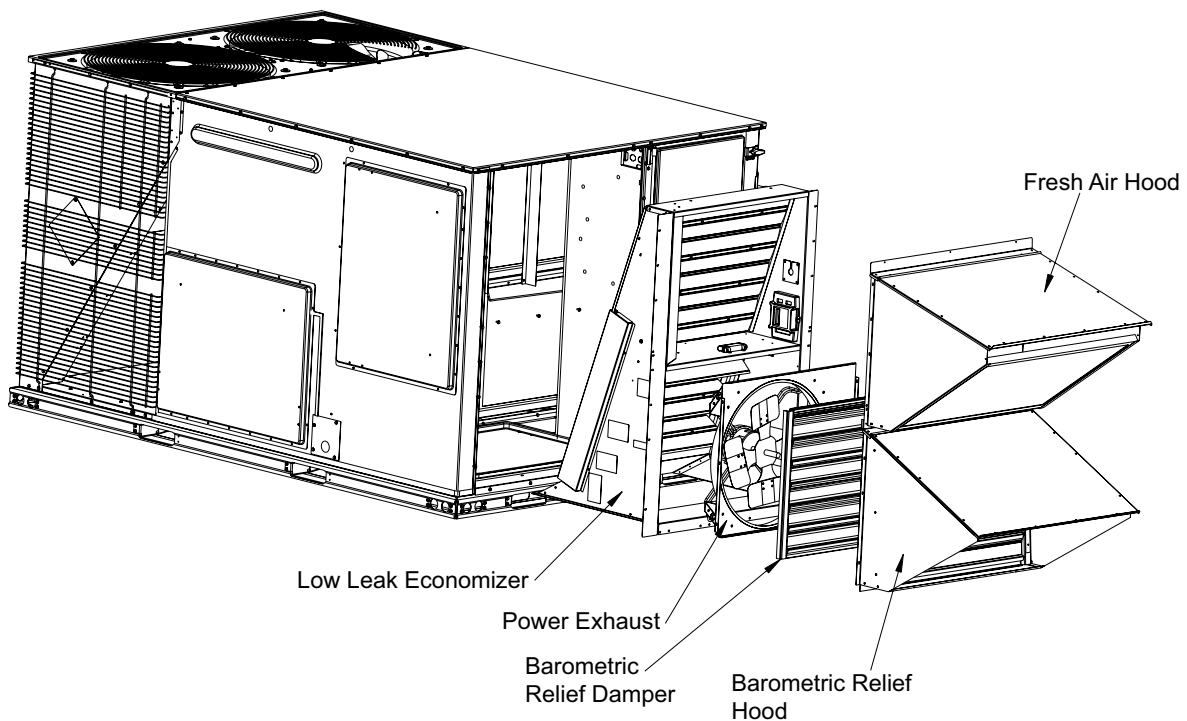

Economizer end return with power exhaust

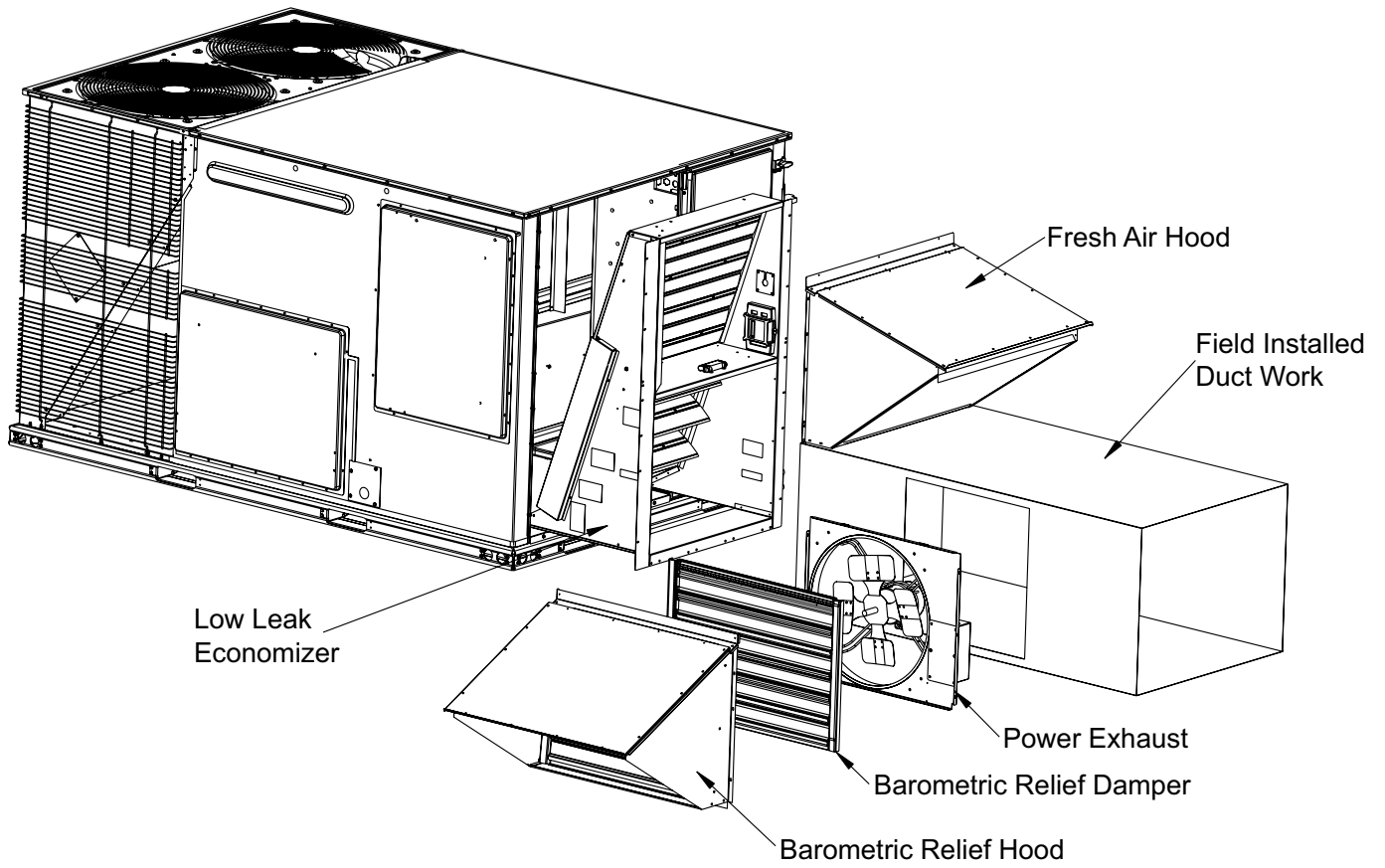

Field-installed horizontal economizer with power exhaust

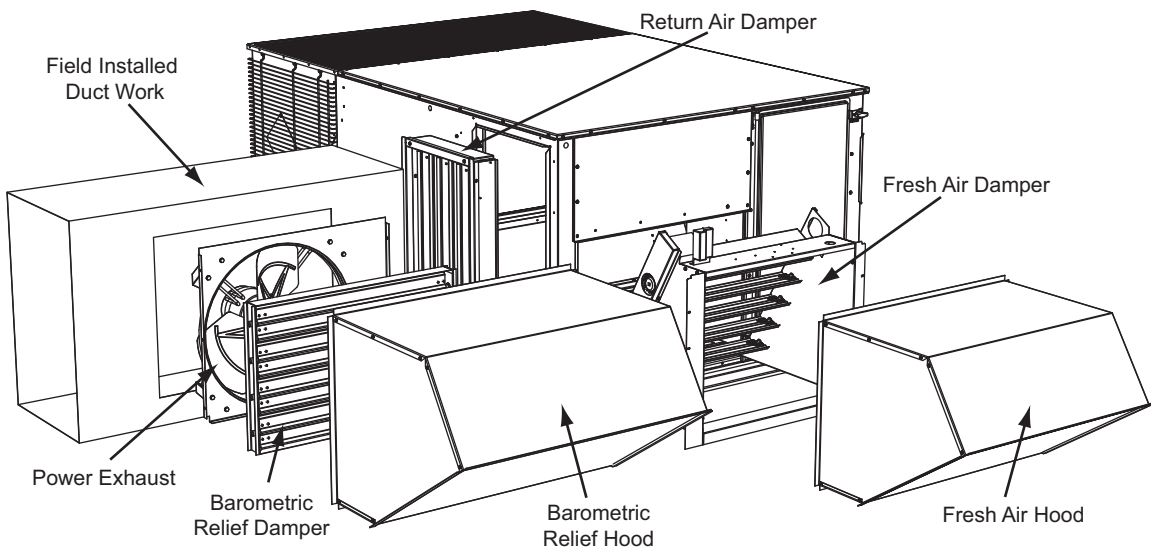

Subject to change without notice. Printed in U.S.A.
Copyright © 2023 by Johnson Controls, Inc. All rights reserved.

5167824-YTG-P-0323
Supersedes: 5167824-YTG-O-1122